



FEATURES

- **Non-Intrusive one-man calibration**
- **Explosion-Proof enclosure Cl. 1, Div. 1 & 2, Gr. B, C, D**
- **6" Back-lit LCD Display with Bargraph and Trending**
- **4-20mA Output**
- **User Adjustable Dual Alarm Relays**
- **RS-485 Modbus Optional**
- **NRTL/ATEX Certifications**

ST-48 Carbon Monoxide (CO) Combustible Gas Monitor

ITEM#: 95107

Product Summary

The PureAire ST-48 Carbon Monoxide (CO) Combustible Gas Monitor is ideal for facilities that require continuous monitoring of carbon monoxide gas in hazardous areas. The enclosure is specifically designed to prevent an explosion. The monitor is best suited for environments such as refineries, parking garages, laboratories, natural gas locations, and the oil and gas industry where carbon monoxide is present. Operator interface is via a menu driven magnetic keypad allowing full access without opening the enclosure. The monitor is housed in a NEMA 7 explosion proof enclosure suitable for Class 1, Division 1 and 2, Group B, C, and D.

Industries That Need This Product

- *Refineries*
- *Natural Gas Operations*
- *Laboratories*
- *Parking Garages*
- *Oil and Gas*

Why Choose PureAire?

PureAire Monitoring Systems, Inc. is an industry leader in oxygen monitoring and gas detection. For over 20 years, we have dedicated ourselves to the safety of our clients, and the customers they serve, by manufacturing monitors that are long-lasting, accurate, and reliable. PureAire takes pride in providing exceptional customer service along with 24/7 availability to our technical service department.

Why an ST-48 Carbon Monoxide (CO) Combustible Gas Monitor?

The PureAire ST-48 Carbon Monoxide Combustible Gas Monitor is designed for continuous monitoring where carbon monoxide, a toxic, combustible gas is used, and the risk of an explosion, or a leak pose a hazard to personnel.

Set Up

Secure the ST-48 monitor to the wall so the display is visible, and connect the monitor to the power source. The ST-48 will begin sampling carbon monoxide (CO) after a brief startup period. Carbon monoxide levels are displayed clearly on the screen for easy access and visibility.

Top Advantages of ST-48 Combustible Gas Monitor



Gas Detector Alarms

PureAire's ST-48 Combustible Gas Monitor comes with 2 adjustable alarm set-points that can connect to a horn/strobe, exhaust fans, 8 channel controller, remote display, or into building systems. Alarm signals also can tie into automatic shut-off valves when carbon monoxide levels reach an unsafe OSHA threshold.



Easy To Use

The ST-48 Combustible Gas Monitor provides constant monitoring with little to no adjustments, saving you time and money while allowing the monitor to operate seamlessly.

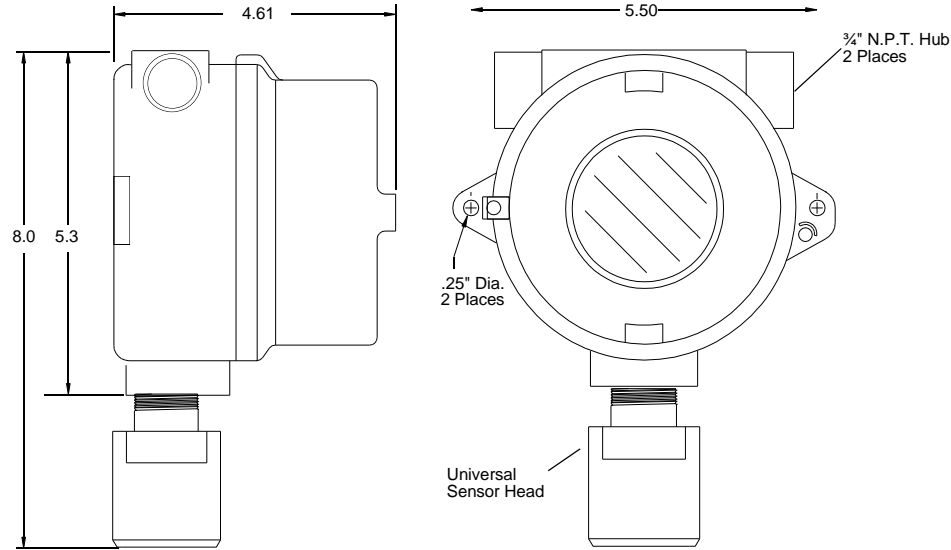

Top Accessories



8 Channel Controller for Gas Monitors

ITEM #: 99058



Remote Digital Display

ITEM #: 99091



Red Horn/Strobe 24VDC

ITEM #: 42002



1-888-788-8050

info@pureaire.net
pureairemonitoring.com

1140 Ensell Road
Lake Zurich, IL 60047
1-847-726-6000