



## FEATURES

- Bright red 1 inch LED digital display showing oxygen, carbon dioxide, or toxic gas readings
- Built-in 90dB audible alarm and fault status
- Two-tone horn distinguishes between alarm 1 and alarm 2
- User adjustable dual-level alarm setpoints
- 3-year warranty

## Remote Digital Display and Alarm

- ITEM#: 99091- Oxygen 0-25%
- ITEM#: 99183 - Carbon Dioxide 10,000 ppm
- ITEM#: 99193- Carbon Dioxide 50,000 ppm
- ITEM#: 99185 - LEL 0-100%
- ITEM#: 99186 - Oxygen 95%
- ITEM#: 99187 - Oxygen 1,000 ppm

### Product Summary

PureAire's Remote Digital Display and Alarm is designed for use with our complete line of oxygen and carbon dioxide monitors, as well as our toxic and corrosive gas detectors. It is ideal for use in locations where oxygen or toxic gas levels must be at safe thresholds before employees enter the area. The remote display provides accurate readings from up to 250 feet from the monitor. It is well suited for use in environments such as freezers, hospitals, laboratories, agricultural grow rooms, the oil and gas industry, and any locations where oxygen or toxic gas levels must be monitored. The unit comes with 2 user-selectable alarm setpoints, large LED screen, and a built-in 90dB horn to alert personnel to unsafe conditions.

### Facilities That Need This Product

- *Food and Beverage*
- *Research and Development*
- *Healthcare*
- *Laboratory*
- *Pharmaceutical*
- *Oil and Gas Refineries*

### Why choose PureAire?

PureAire Monitoring Systems, Inc. is a leader in oxygen monitoring and gas detection. For over 20 years, we have dedicated ourselves to the safety of our clients, and the customers they serve, by manufacturing monitors that are long-lasting, accurate, and reliable. PureAire takes pride in providing exceptional customer service, along with 24/7 availability to our technical service department.

### Why a Remote Digital Display and Alarm?

The Remote Digital Display and Alarm should be used in locations where oxygen or toxic gas levels pose a hazard to personnel. It is ideal for use in confined spaces where the monitor may not be easily accessible, or where there could be a safety hazard in entering the area without first verifying that oxygen levels are safe.

### What Monitors can be connected to a Remote Digital Display and Alarm?

The Remote Digital Display is compatible with PureAire's line of oxygen monitors, toxic and corrosive gas detectors. It can be connected to a programmable logic controller (PLC) to provide status and alarm information throughout the facility.

### Easy to Use

Simply secure the monitor to the wall, connect a length of cable (up to 250 feet long) to the remote digital display, and plug in the monitor. After a brief start up, the monitor will begin measuring the oxygen or toxic gas levels. The gas levels will be visible on the remote display screen, for easy access and visibility.

# Top Advantages of a Remote Digital Display and Alarm



## Remote Digital Display and Alarm

PureAire's Remote Digital Display and Alarm is compatible with our line of oxygen monitors, toxic and corrosive gas detectors. The remote digital display provides accurate readings from up to 250 feet from the monitor and, can be connected to a programmable logic controller (PLC).



## Easy To Use

The Remote Digital Display and Alarm connects easily to our monitors and gas detectors. The easy to read screen displays current oxygen or gas readings from up to 250 feet from the monitor. Personnel can verify safe levels are present before entering hazardous areas.

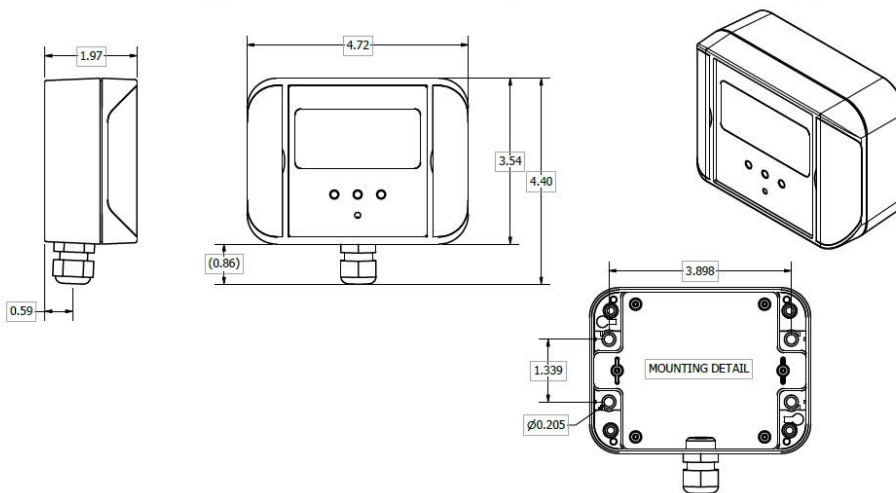

## Example of Compatible Monitors-Please contact PureAire for a complete list



**Oxygen Deficiency Monitor**

ITEM #: 99016



**Explosion Proof Oxygen Monitor**

ITEM#: 99020



**Dual O2/CO2 Monitor**

ITEM #: 99039



**1-888-788-8050**

info@pureaire.net  
pureairemonitoring.com

1140 Ensell Road  
Lake Zurich, IL 60047  
1-847-726-6000