



# Air Check✓ Lite Toxic Gas Monitor

Instruction Manual

Part Number 99046



**PureAire Monitoring Systems, Inc.**

1140 Ensell Road

Lake Zurich, Illinois 60047

Phone: 847-726-6000

Fax: 847-726-6051

Toll-Free: 888-788-8050

[www.pureairemonitoring.com](http://www.pureairemonitoring.com)

Rev 1.1 August 2023

# *Welcome to PureAire Monitoring Systems*

I'd like to thank you for investing in our continuous life safety and process control toxic gas monitoring systems.

PureAire offers an unbeatable combination of experience and innovation in solving the safety and environmental needs of our customers. We're capable of providing small systems of a few points to a total multi-point turnkey computerized package.

PureAire's proprietary sensor cell technology and state-of-the-art electronics are designed to interface with the latest digital or PLC based control systems. We believe that our experience, innovative products, and commitment to service will satisfy your specific monitoring needs now and in the future.

Our growth is a result of our total commitment to supporting our customers. We're available 24 hours a day, 7 days a week to help you when you need us. Our 24-hour Emergency phone number is 1-224-443-5445. We can provide field service, preventative maintenance programs and training to your technicians in the operation of our equipment. Our goal is to provide the best after sale service and support in the industry. That's just one way PureAire takes that extra step to ensure your complete satisfaction.

Thank you again for investing in PureAire Monitoring Systems for your monitoring needs and I'm proud to welcome you to our family of valued and satisfied customers.

Sincerely,



Albert A. Carrino  
President

# Table of Contents

---

1: Introduction.....	2
1.1 Key Features .....	2
1.2 Component identification.....	3
2: Specifications.....	6
2.1 Performance Specifications .....	7
2.2 Gas Detection System .....	7
2.3 Signal Outputs.....	7
2.4 Electrical Requirements .....	7
2.5 Physical Characteristics .....	8
3: Installation .....	9
3.1 Site Requirements .....	9
3.2 Mounting.....	9
3.3 Sensor Installation.....	10
3.4 Wiring .....	11
3.5 Initial Startup .....	11
4: Normal Operation .....	12
4.1 Signal Outputs.....	12
4.2 Instrument Faults .....	12
4.3 Routine Maintenance Schedule .....	12
4.4 Loss of Power Indicator .....	13
5: Maintenance & Calibration.....	14
5.1 Sensor Cell Removal and Installation.....	14
5.2 Electrolyte Replacement .....	15
5.3 Sensor Calibration.....	19
6: Drawings.....	24
7: Appendix.....	29

# 1: Introduction

---

The *Air Check ✓ Lite* Toxic Gas Monitoring System is a self-contained gas detection system suitable for keeping a wide range hazardous gases under continual surveillance. Each system consists of an amperometric, electrochemical sensor cell and two-wire transmitter. The *Air Check ✓ Lite* Monitoring System may be used as a stand-alone gas detector, linked to an optional controller (RX-1G), or connected to your own centralized control and surveillance system.

This manual covers the installation, operation, and maintenance of the *Air Check ✓ Lite* Monitoring System for the following gases:

Ammonia (NH <sub>3</sub> )	0 to 75 ppm
Arsine (AsH <sub>3</sub> )	0 to 1 ppm
Boron Trichloride (BCl <sub>3</sub> )	0 to 9 ppm
Carbon Monoxide (CO)	0 to 100 ppm
Chlorine (Cl <sub>2</sub> )	0 to 3 ppm
Diborane (B <sub>2</sub> H <sub>6</sub> )	0 to 1 ppm
Fluorine (F <sub>2</sub> )	0 to 1 ppm
Hydrogen (H <sub>2</sub> )	0 to 4% vol
Hydrogen Bromide (HBr)	0 to 9 ppm
Hydrogen Chloride (HCl)	0 to 15 ppm
Hydrogen Fluoride (HF)	0 to 9 ppm
Hydrogen Sulfide (H <sub>2</sub> S)	0 to 30 ppm
Nitric Oxide (NO)	0 to 100 ppm
Nitrogen Dioxide (NO <sub>2</sub> )	0 to 9 ppm
Oxygen Deficiency (O <sub>2</sub> )	0 to 25%
Phosphine (PH <sub>3</sub> )	0 to 1 ppm
Silane (SiH <sub>4</sub> )	0 to 15 ppm

## 1.1 Key Features

---

The *Air Check ✓ Lite* Monitoring System incorporates a number of user-friendly features designed to simplify installation, operation, and maintenance.

### 1.1.1 Plug-in Sensor

The system's renewable, electrochemical sensor features a special plug-in design to simplify sensor installation and removal.

### 1.1.2 Smart Electronics

The sensor cell also incorporates a special electronic circuit which permits "ex-situ" calibration. This smart circuitry also alerts the user to low electrolyte, sensor faults, and other problems which may interrupt surveillance.

## 1.2 Component Identification

### 1.2.1 Front View Exterior

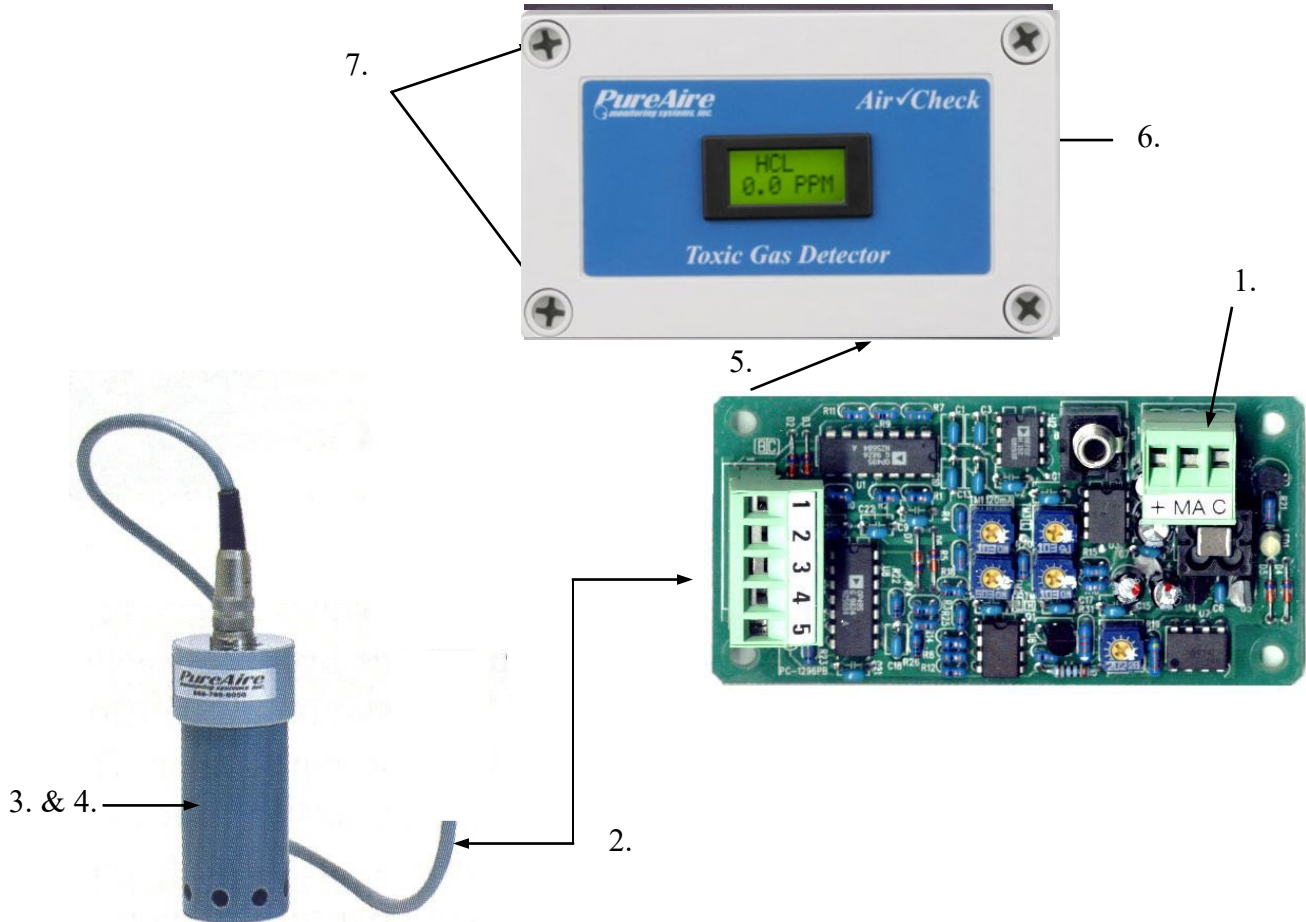

1. **4-20 mA Signal Output Terminal** — This connection serves as both the 4-20 mA output connection and 24 VDC power input connection. See section 3: Installation for more information.
2. **Sensor Cable and Connector** — Allows remote mounting of sensor. Sensor plugs into receptacle on end of sensor cable.
3. **Sensor Cover** — This cover protects the gas sensor. It threads onto the upper portion of the sensor.
4. **Gas Sensor** — An amperometric, electrochemical sensor which detects and measures the target gas. Different gas sensors are required to detect different gases. When exposed to the target gas, the sensor outputs an electrical signal proportional to the gas concentration.
5. **Cable Port** — This is the opening in the transmitter housing for connecting the 4-20 mA output and 24 VDC power cable.
6. **Transmitter Cover** — A removable cover that protects the interior of the transmitter.
7. **Transmitter Cover Fasteners** — These captive screws secure the transmitter cover in place.

### 1.2.2 Transmitter Interior

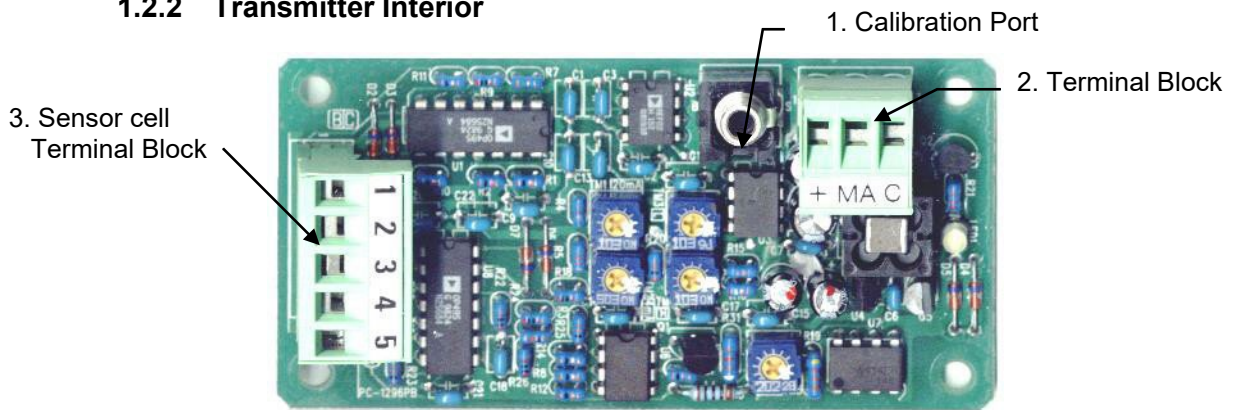

1. **Calibration Port** — This port is used for when calibrating *Air Check ✓ Lite* Monitoring Systems which do not have a digital display. See Sensor Calibration elsewhere in this manual.
2. **Terminal Block** — This terminal block is where the VDC power/analog output connection is made.
3. **Sensor Cell Terminal Block** — This terminal block is where the sensor cell cable output connection is made.

### 1.2.3 Electrochemical Sensor

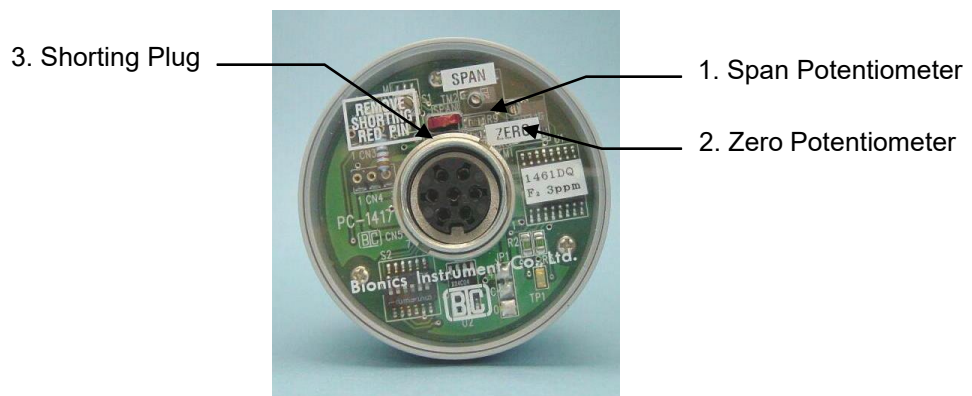

1. **Span Potentiometer** — This potentiometer is used to adjust the sensitivity of the sensor cell. It should only be adjusted when calibrating the instrument.
2. **Zero Potentiometer** — This potentiometer is used to adjust the instrument's 4 mA analog output signal to ensure that it is transmitting a 4 mA signal when the instrument is reading a zero concentration.
3. **Shorting Plug** — The sensor is shipped with a jumper (shorting plug) in place. This plug should be removed prior to sensor installation and replaced whenever the sensor is removed for extended periods of time (storage, etc.).

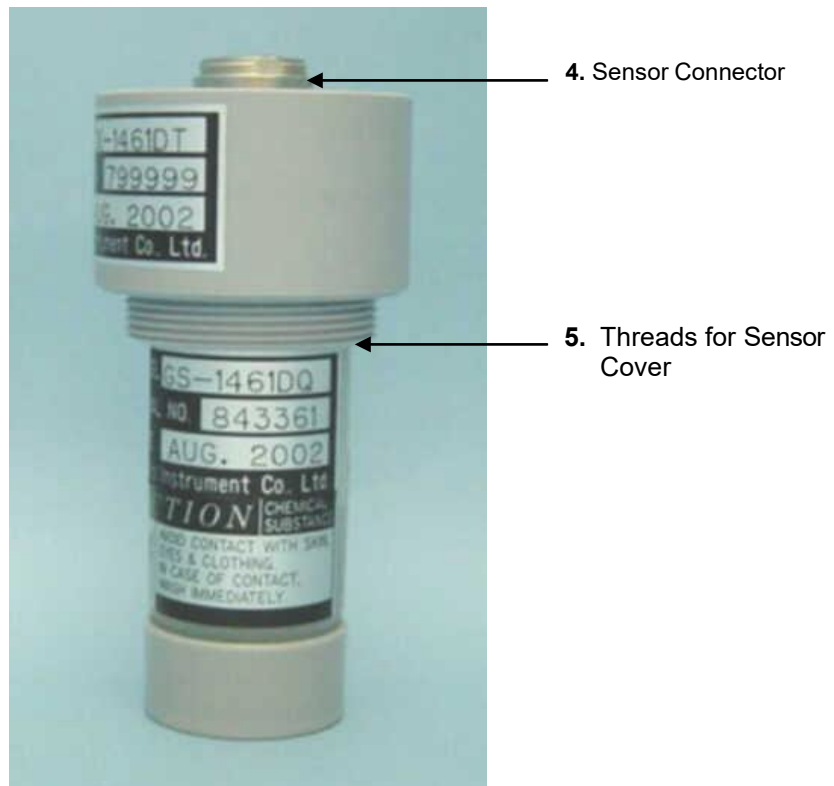

- 4. **Sensor Connector** — Female connector; plugs into receptacle on sensor cable.
- 5. **Threads for Sensor Cover** — Secure sensor cover onto sensor body.

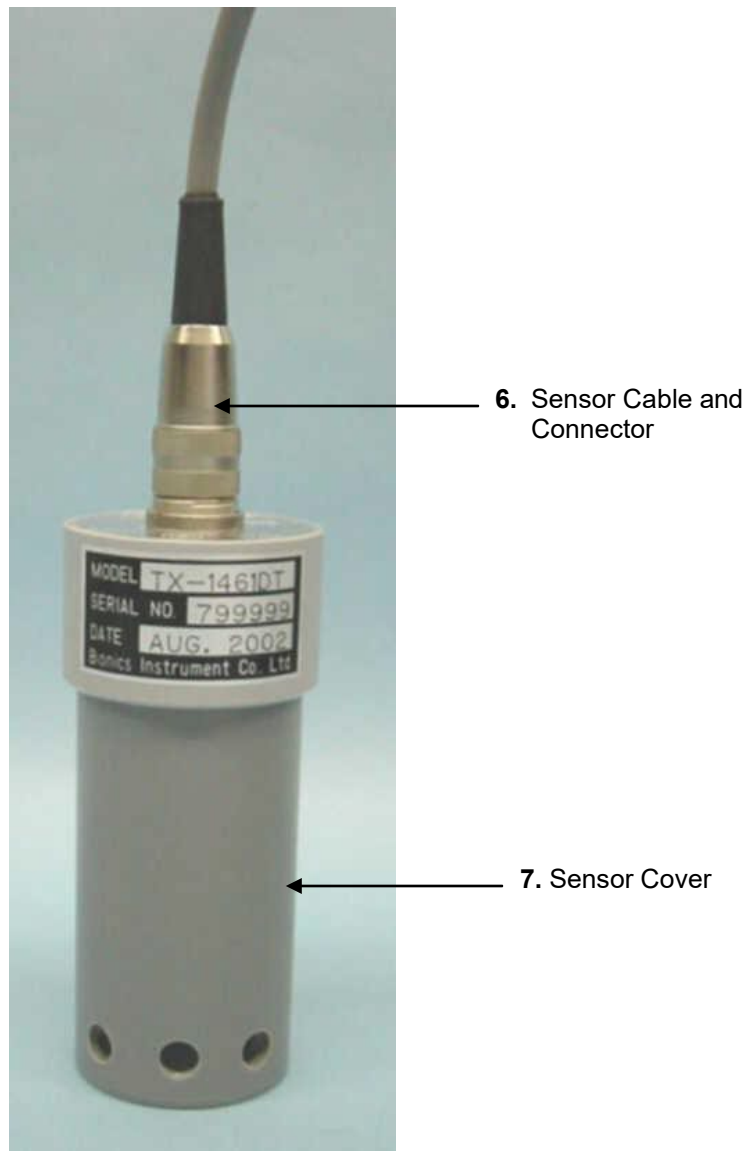

- 6. **Sensor Cable and Connector** — Allows remote mounting of sensor. Sensor plugs into receptacle on end of sensor cable.
- 7. **Sensor Cover** — This cover protects the gas sensor. It threads onto the upper portion of the sensor body.

## 2: Specifications

---

▼ **NOTE:** Due to our commitment to continual product improvement, all specifications are subject to change without notice.

### 2.1 Performance Specifications

---

Sensor Type:	Plug-in diffusion type electrochemical cell.
Response Time:	Within 30 seconds to T90.
Repeatability:	±10% of full scale.
Fault Indicators:	Loss of VDC power (analog signal drops to 0 mA). Low electrolyte (analog signal drops to 2 mA; 0 mA on request). Sensor removed (analog signal drops to 2 mA; 0 mA on request).
Operating Temperature:	14° to 113°F (-10° to +45°C); consult PureAire for lower operating temperatures.
Humidity:	Sensor dependent; typically, 20 to 95% RH; consult PureAire for sensors which can operate in 100% condensing RH environments.

### 2.2 Gas Detection System

---

Type:	Renewable GS-DQS electrochemical gas sensor.
Sensor Life:	4 to 5 years under normal conditions.
Detectable Gases:	See Appendix for gases, measuring ranges, and sensor part numbers.

### 2.3 Signal Outputs

---

Analog Output:	DC 4-20 mA
----------------	------------

### 2.4 Electrical Requirements

---

Power:	24 VDC external power.
Consumption:	Approximately 100mA

## 2.5 Physical Characteristics

---

Dimensions:	4.9 (W) x 3 (H) x 3 (D) inches; 125 x 75 x 75 mm
Weight:	1.1 pounds (0.5 kg)
Enclosure Type:	General purpose; not intended for explosive atmospheres.
Installation Options:	Bulkhead fittings for remote sensor installation.

# 3: Installation

---

## 3.1 Site Requirements

---

The *Air Check ✓ Lite* enclosure should be mounted in an area free of vibration and electrical noise or interference. If possible, avoid areas with high temperatures or relative humidity.

▼ **WARNING:** *The Air Check ✓ Lite is not designed for installation in hazardous areas. Consult PureAire for information on enclosures for use in hazardous environments.*

## 3.2 Mounting

---

### 3.2.1 Transmitter

The *Air Check ✓ Lite* transmitter is designed primarily for wall mounting and should be installed at a height convenient for operation, maintenance, and calibration of the instrument. Allow sufficient space around the transmitter to permit access for maintenance and calibration.

### 3.2.2 Sensor

▼ **IMPORTANT:** *The Air Check ✓ Lite must be mounted with the sensor pointed directly down. Do not install with the sensor at greater than a 30° angle from vertical.*

The sensor should be installed in a location where gas leaks are likely to occur or where released gases may accumulate. It should be mounted no closer than 12 inches above floor level. Air flow within the monitored area, the characteristics of the target gas (lighter or heavier than air), and the position of workstations and personnel should all be considered in determining the most suitable installation location. The sensor should be mounted. Fittings for bulkhead installation are available; consult PureAire.

### 3.3 Sensor Installation

▼ **IMPORTANT:** Be careful not to turn the sensor or touch the membrane on the bottom of the sensor during installation.

▼ **IMPORTANT:** Be sure to remove the jumper from the sensor electronics prior to installing the sensor. Failure to do so will result in a sensor fault indication upon startup.

Remove the transmitter cover. It is held in place by captive screws mounted in each of its four corners.

Insert the sensor cable through the strain relief and into the transmitter housing.

Connect the 5-conductor sensor cable to the 5-pin Phoenix connector on the transmitter PCB per the following table:

▼ **NOTE:** The terminal block may be removed from the printed circuit board to make these connections. Be sure to replace the terminal block securely once all connections have been made.

Sensor Cable Type	Wire Color	Location
5-Wire Sensor Cable	Black	Terminal 1
	White	Terminal 2
	Red	Terminal 3
	Green	Terminal 4
	Yellow or Brown	Terminal 5

Sensor cell 5-pin connector

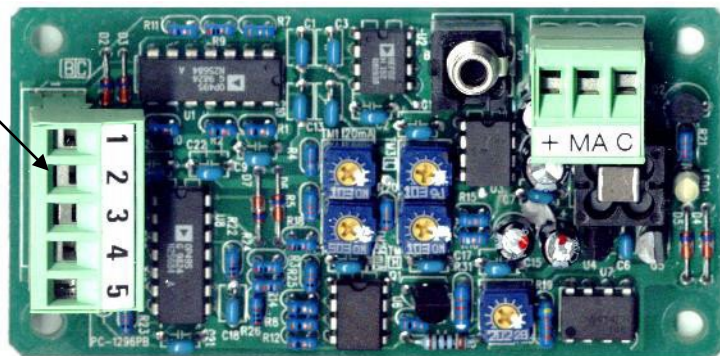

▼ **NOTE:** This is a keyed connector. Twisting the connector will damage it.

4. Connect the sensor cell male connector into the GS-DQS sensor cell. Align the connector properly, plug it in, and turn the knurled locking ring until tight



Sensor cell connector

### 3.4 Wiring

The *Air Check ✓ Lite* uses a single, 3-wire shielded cable for analog output and 24 VDC power input. A three-wire shielded cable (3-conductor, 18 AWG stranded) General Cable E2203S.30.860 is recommended for the connection. The maximum permissible cable length is 0.62 miles (1 km).

The analog out and VDC power in connections are made on the terminal block inside the transmitter housing.

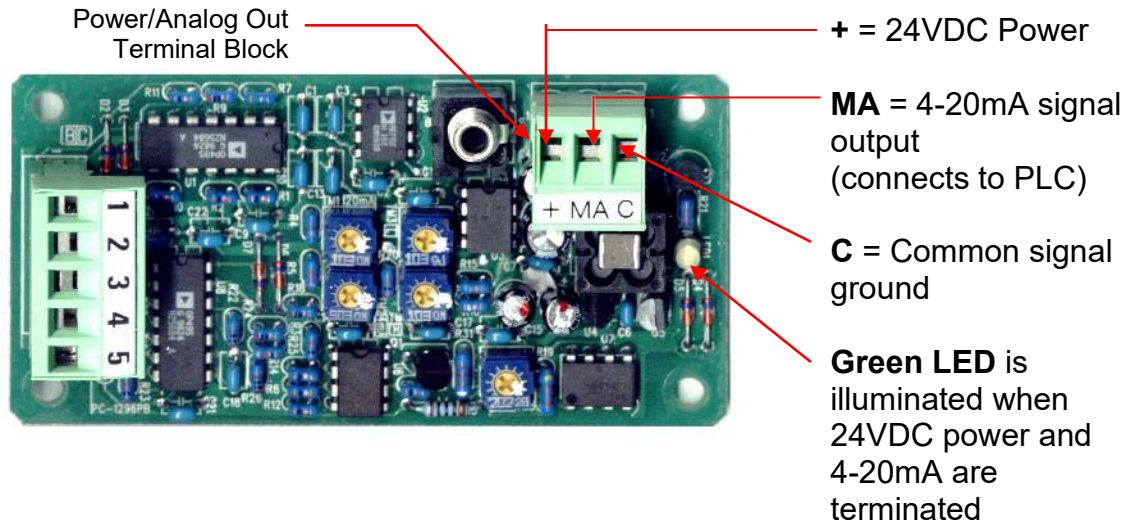

These connections are made as follows:

Pin #	Connection	Description
1	Power	DC +24V Input
2	Signal Out	4-20mA Output
3	Common (Signal Ground)	0V

**(IMPORTANT:** *If connecting directly to a 24VDC power source, you must use a 100-ohm resistor between pins 2 and 3 to simulate a load. Without this resistor the Air Check ✓ Lite will not operate properly.*

### 3.5 Initial Startup

Once installation of the gas detector has been completed, it is ready for startup. The following procedures should be performed before putting the instrument into operation:

1. Check the integrity of all wiring.
2. Apply 24 VDC power.

The instrument should now be operating properly.

## 4: Normal Operation

---

The *Air Check ✓ Lite* is a single point monitor designed for the continuous detection and measurement of hazardous gas leaks.

### 4.1 Signal Outputs

---

The *Air Check ✓ Lite* outputs a continuous 4-20 mA analog signal proportional to the measured concentration of the target gas. 4 mA represents 0 ppm; 20 mA represents the top of the measuring range for the installed sensor.

### 4.2 Instrument Faults

---

The *Air Check ✓ Lite* incorporates a number of self-checking features to ensure reliable operation. In the event that a fault condition is detected, the analog output signal is altered as follows:

Condition	Analog Signal
Sensor cell removed	Analog output drops to 2 mA (0 mA on request)
Electrolyte in sensor low	Analog output drops to 2 mA (0 mA on request)
Power to transmitter lost	Analog output drops to 0 mA
Transmitter cable cut	Analog output drops to 0 mA

### 4.3 Routine Maintenance Schedule

---

Continuous gas detection systems depended upon to measure and detect hazardous gas leaks in the workplace require periodic maintenance to ensure proper operation. The frequency with which this routine maintenance is required depends on the environment, since temperature, humidity, gas concentrations, and dust all affect system operation.

The following table is intended to serve as a general guideline for routine maintenance. The conditions in your particular application, as well as your organization's maintenance policies, will ultimately determine the best routine maintenance schedule for your equipment.

**4.3.1 Routine Visual Checks**

Items to check	Check for power and proper operation
Condition / status when operating properly	Unit should be outputting a 4 mA signal when no gas is present. On instruments with a digital readout, display should also show 0 when no gas is present.
Corrective actions	If analog signal (or digital display) is higher than 4 mA in a zero gas condition, adjust as required to the environment

**4.3.2 Recommended Routine Maintenance Schedule**

Routine Visual Checks	Monthly
Electrolyte Replacement	Every 6 months*
Sensor O-ring and Membrane Replacement	Every 6 months*
Sensor Calibration	Every 6 months

\* Hydrogen cell can operate 1-2 years between recharges.

**4.4 Loss of Power Indicator**

---

In the event the *Air Check ✓ Lite* loses VDC power, the 4-20 mA analog output signal drops to 0.

# 5: Maintenance & Calibration

Qualified personnel should only perform maintenance and calibration.

## 5.1 Sensor Cell Removal and Installation

### 5.1.1 Sensor Removal

1. Remove the sensor protective sleeve by rotating counter-clockwise (right to left).
2. Loosen the threaded connector holding the sensor cable to the sensor.
3. Unplug the sensor.

▼ **CAUTION:** *Do not twist the sensor; pull straight down.*

▼ **CAUTION:** *Avoid spilling electrolyte out of the small opening on the side of the sensor.*

▼ **IMPORTANT:** *Do not touch the membrane at the bottom of the sensor. Oil from your hands or fingers will adversely affect performance.*

### 5.1.2 Sensor Installation

▼ **IMPORTANT:** *Be sure to remove the jumper (shorting wire) from the sensor prior to installation. It is located to the left of the zero and span potentiometers.*

▼ **IMPORTANT:** *Be careful not to turn the sensor or touch the membrane on the bottom of the sensor during installation.*

1. Remove the jumper (shorting wire) from the sensor electronics. It is located to the left of the zero and span potentiometers.

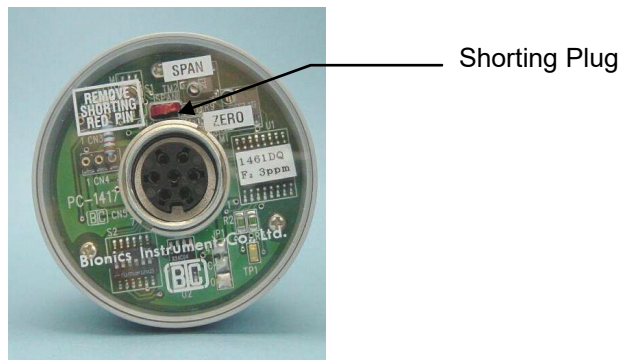

2. Plug the sensor into the receptacle on the sensor cable and thread/tighten the knurled connector.
3. Screw the sensor protective sleeve onto the sensor. Do not over-tighten.

## 5.2 Electrolyte Replacement

▼ **CAUTION:** *PureAire recommends wearing protective gloves and safety glasses when replacing sensor electrolyte. Be sure to adhere to your facility's chemical handling guidelines and procedures.*

1. Remove the sensor as outlined in section 5.1.1.
2. Place your finger over the pressure compensation port and turn the sensor upside down. Remove the box nut, membrane retainer ring, membrane, O-ring, and silicon sheet (depending on sensor model).

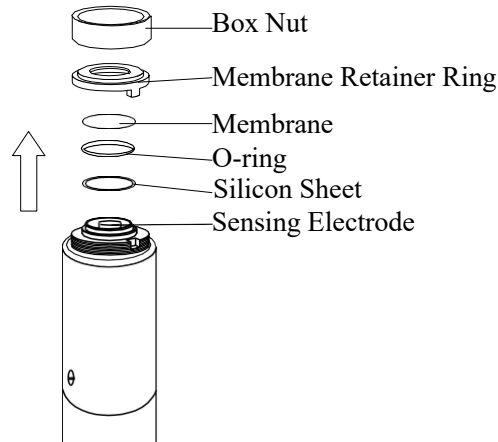

3. Place the sensor over the beaker as shown and pour the old electrolyte into the beaker. Some will remain in the sensor until the pressure compensation plug is removed. Remove the milli seal covering the plug and then the plug to release the electrolyte into the beaker.

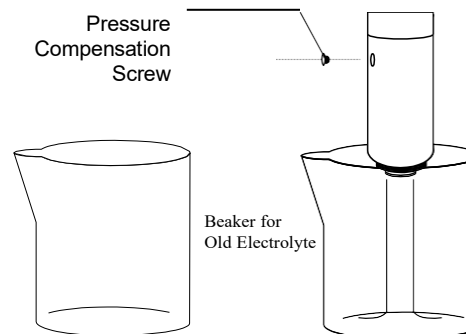

**NOTE:** The Pressure Compensation Screw has a Teflon membrane fixed to the inside of the screw.

**Never remove this membrane.**

4. Hold the sensor in your hand with the sensing electrode up. Hold a piece of paper tissue over the pressure compensation port with your thumb. Pour 10 ccs of fresh electrolyte into the sensor and rinse. Discard into the beaker.

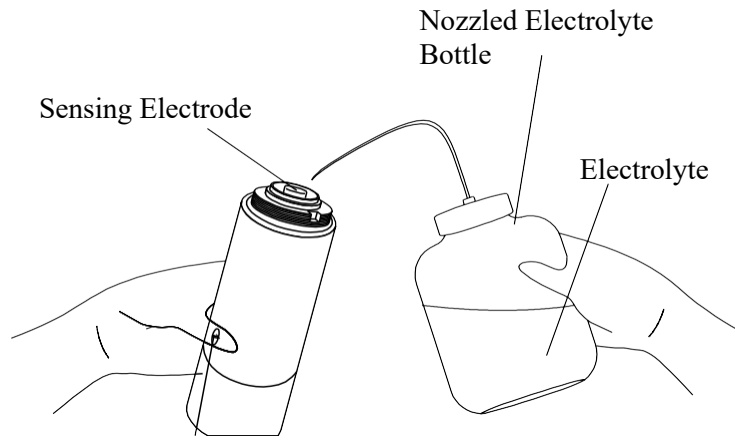

5. Wipe the sensing electrode and the surrounding area with a dry paper tissue.

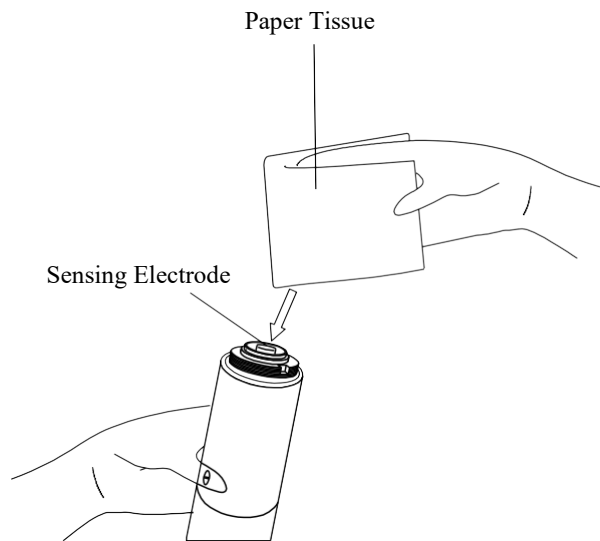

- Place a new silicone sheet (if used) and O-ring on the sensor. Make sure that the area is dry of electrolyte.

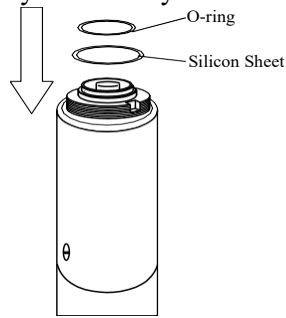

- Apply a drop of electrolyte on the sensing electrode.

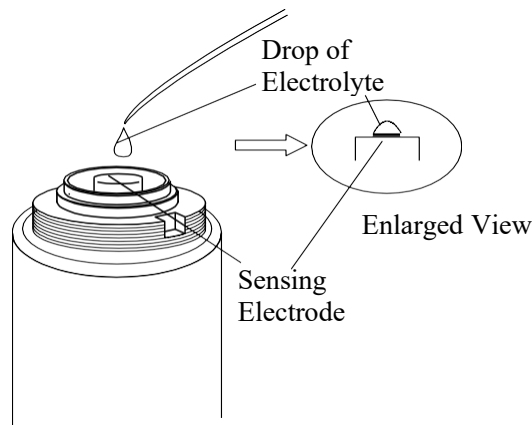

- Place a new membrane on the sensor, with the bead of electrolyte between the electrode and the membrane.

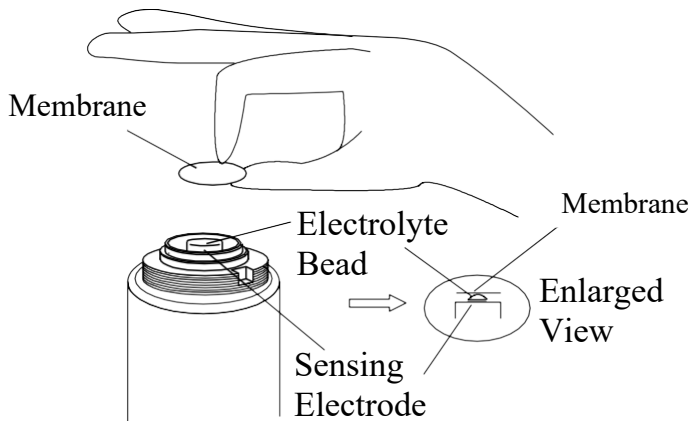

▼ **NOTE:** Do not touch membrane with bare fingers. Oil from your fingers may adversely affect performance.

- Place the retainer ring over the membrane and then place the box nut over the retainer ring. Turn box nut clockwise until hand tight; continue tightening until the box nut can no longer be moved by hand. **CAUTION: Sensor cell response will be affected if box nut is too loose.**

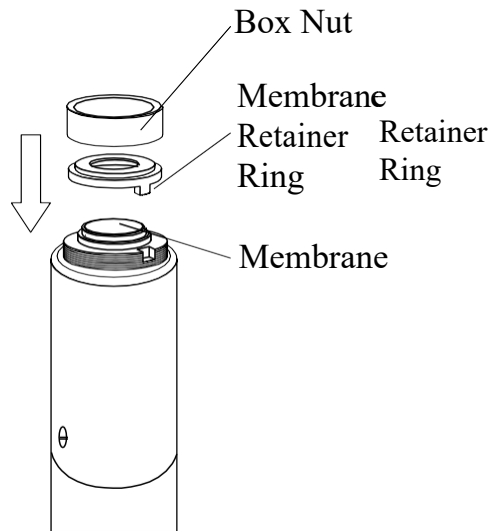

10. Hold the sensor in your hand with the electrode down. Pour fresh electrolyte in until it reaches the MAX. mark.

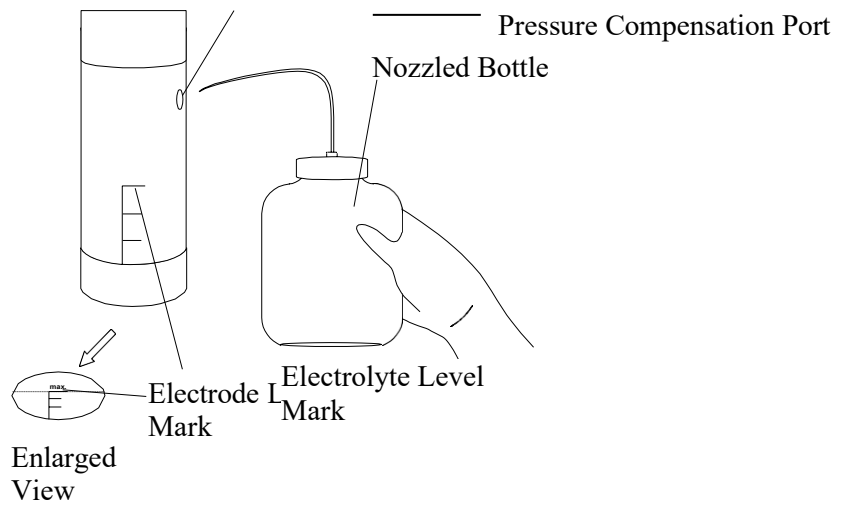

▼ **NOTE:** *MAX. level differs from sensor to sensor.*

11. Wipe the pressure compensation port and its surrounding area with a dry paper tissue.

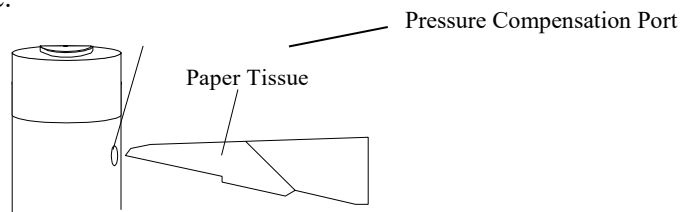

12. Insert the pressure compensation plug into the port and cover with a new milli seal.

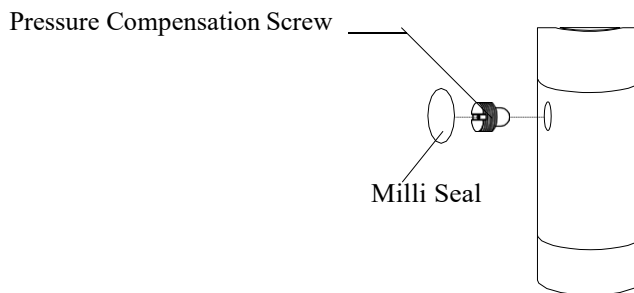

13. Reinstall the sensor as outlined in section 5.1.2.

**➔NOTE:** *When storing the sensor cell never store the sensor cell horizontal with the Pressure Compensation Screw positioned down or store the sensor cell upside down. This can cause the electrolyte to leak from the sensor cell pressure compensation screw.*

## 5.3 Sensor Calibration

▼ **NOTE:** This procedure should be performed in a gas free atmosphere at normal room temperature (68°F; 20°C).

The *Air Check ✓ Lite* requires periodic calibration with the appropriate standard gas. Calibration should be performed whenever:

- The membrane or electrolyte is replaced.
- The entire sensor is replaced.
- Six months has passed without membrane, electrolyte, or sensor replacement.

The PureAire Calibration Kit (optional) is recommended for calibration.

### 5.3.1 Gas Generation and Calibrating Kits

For generating a calibrating gas, the following PureAire Gas Generation Kits are recommended. They are available by separate order.

Calibration Kit Model	K-I PH <sub>3</sub>	K-II Cl <sub>2</sub>	K-III HCN	K-IV SO <sub>3</sub>	K-V H <sub>2</sub> S	K-VI NH <sub>3</sub>	K-VII HCl	K-VIII HF
Gas generation tubes	1 box		1 box	1 box	1 box			
Gas generation solution (10 ml)	2 bottles		2 bottles	2 bottles	2 bottles			
Soft paper towels	1 pack		1 pack	1 pack	1 pack	1 pack		
Gas detection tube	1 box	1 box	1 box	1 box	1 box	1 box	1 box	1 box
Gas sampling bags (2 liter)	2	2	2	2	2	2	2	2
Gas sampling pump No. 800	1	1	1	1	1	1	1	1
Double bellows	1	1	1	1	1	1	1	1
Teflon® tube (φ6 × φ4)	1 m	1 m	1 m	1 m	1 m	1 m	1 m	1 m
Calibration Cap (optional)		1	1	1	1	1	1	1
Mini-pump MP-05 (optional)		1	1	1	1	1	1	1
Instruction manual	1	1	1	1	1	1	1	1
Case	1	1	1	1	1	1	1	1
Silicon tube (φ8 × φ4)	1 m	1 m	1 m	1 m	1 m	1 m	1 m	1 m
Reagent 1		1 bottle				1 bottle	1 bottle	1 bottle
Reagent 2		1 bottle				1 bottle	1 bottle	1 bottle
Dispenser bottle (100 ml)		1 bottle				1 bottle	1 bottle	1 bottle

### 5.3.2 Optional Calibration Equipment

The following equipment is available from PureAire to facilitate gas calibration:

Part Number	Description	Quantity
PUMP2N	High Flow Sampling Pump	1
690100	Calibration Cap for "D" Type Sensor Cells	1

### 5.3.3 Initial Preparation

▼ **NOTE:** *If the Air Check ✓ Lite transmitter is a non-display model, PureAire’s meter adapter (part number 690600) should be used. This allows the operator to plug a VOM digital multimeter into the calibration port on the main electronics board to read the gas concentration.*

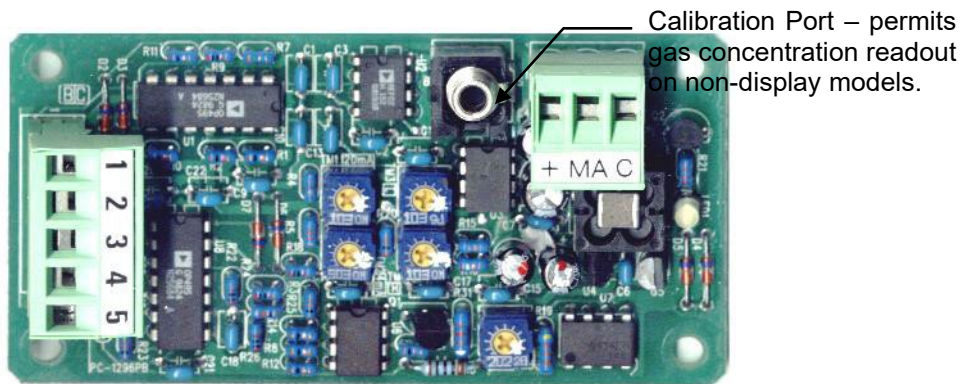

1. If the instrument is connected to a controller, set the controller to Standby mode to avoid accidental alarms.
2. Remove the sensor (as outlined in section 5.1.1).

### 5.3.4 Zero Calibration

▼ **IMPORTANT:** *This procedure should be performed under normal monitoring conditions, without any of the target gas present..*

▼ **NOTE:** *PureAire’s Meter Adapter (p/n 690600) is required for (non-display) transmitters. This allows you to use a VOM digital multimeter to read the gas concentration display.*

1. Check the instrument’s gas concentration reading on either the local display or the digital multimeter.
2. If the display/multimeter does not read a steady “0,” adjust the zero potentiometer on the sensor cell as required. A clockwise rotation increases the display value, a counter-clockwise rotation decreases the display value.

### 5.3.5 Span Calibration

▼ **CAUTION:** *Be sure to observe all safety guidelines when generating and using calibration gases.*

▼ **NOTE:** Gas generation kits are available through PureAire. These kits include instructions and materials for generating calibration gases and precise methods for accurately measuring the concentration of these gases.

▼ **NOTE:** The gas concentration should be close to, but never exceed, full scale.

1. Connect the appropriate sensor adapter to the inlet of the high flow sampling pump and connect the Tedlar “waste gas” bag to the outlet of the pump.
2. Open the valve on the waste gas bag.
3. Connect the flowmeter to the inlet of the sensor adapter and turn the high flow sampling pump “on.”
4. Adjust the pump’s flowrate potentiometer until a flowrate of 0.5 liters/minute is achieved. A clockwise rotation increases flow; a counter-clockwise rotation decreases flow.
5. Recheck the instrument’s zero reading; adjust as required.
6. Generate the calibration gas within a Tedlar bag.

▼ **IMPORTANT:** Be sure to perform the calibration before the concentration of the gas changes. Also, PureAire recommends that you verify that the concentration of the calibration gas is the same after calibration as it was before.

7. Disconnect the flowmeter and connect the Tedlar calibration gas bag to the inlet side of the sensor adapter.
8. Open the valve on the calibration gas bag.
9. Insert the sensor into the sensor adapter by pushing the sensor cell into the adapter.

▼ **NOTE:** Do not twist or “screw” the sensor into the sensor adapter.

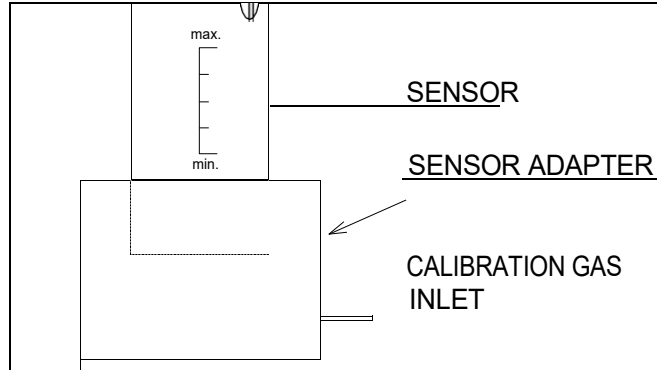

10. Expose the sensor cell to the span gas for 1 to 2 minutes until the gas reading stabilizes.
11. Adjust the span potentiometer on the sensor cell until the displayed gas reading matches the concentration value of the calibration gas. A clockwise rotation increases the display value; a counter-clockwise rotation decreases the display value.
12. Close the valve on the calibration gas bag and permit the instrument to return to a zero reading.
13. Open the valve on the calibration gas bag and verify that the display reading matches the concentration of the calibration gas. Readjust the span potentiometer as required.
14. Close the valve on the calibration gas bag and disconnect it from the calibration cap.

15. Allow the instrument to return to a zero reading. If the instrument has not returned to zero after 5 minutes, readjust the zero potentiometer as required.
  16. Close the valve on the waste gas bag and disconnect from the sampling pump.
  17. Turn the sampling pump “off.”
  18. Remove calibration cap from the sensor cell by gently rocking the cap as you pull downward.
- ▼ **IMPORTANT:** *Do not twist the calibration cap.*
19. Replace the transmitter housing cover.
  20. If the transmitter is connected to a controller, return the controller to the monitoring mode.
- ▼ **WARNING:** *Be sure to dispose of the remaining calibration gas and waste gas properly.*

# 6: Drawings

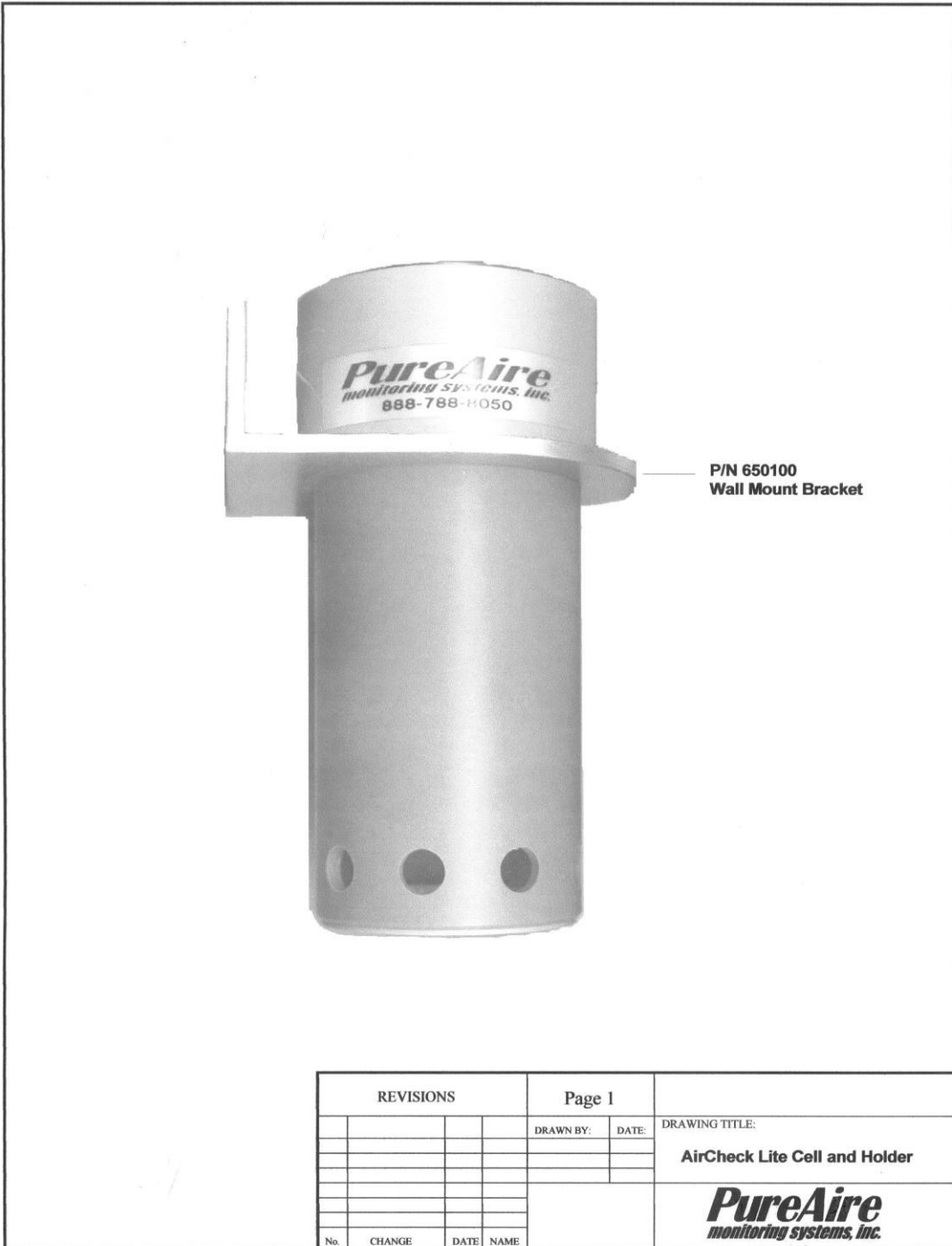

REVISIONS				Page 1		DRAWING TITLE:
				DRAWN BY:	DATE:	AirCheck Lite Cell and Holder
						<b>PureAir</b> monitoring systems, inc.
No.	CHANGE	DATE	NAME			

# Remote DQS cell holder and mounting bracket

---

P/N 650100  
Mounting  
Bracket

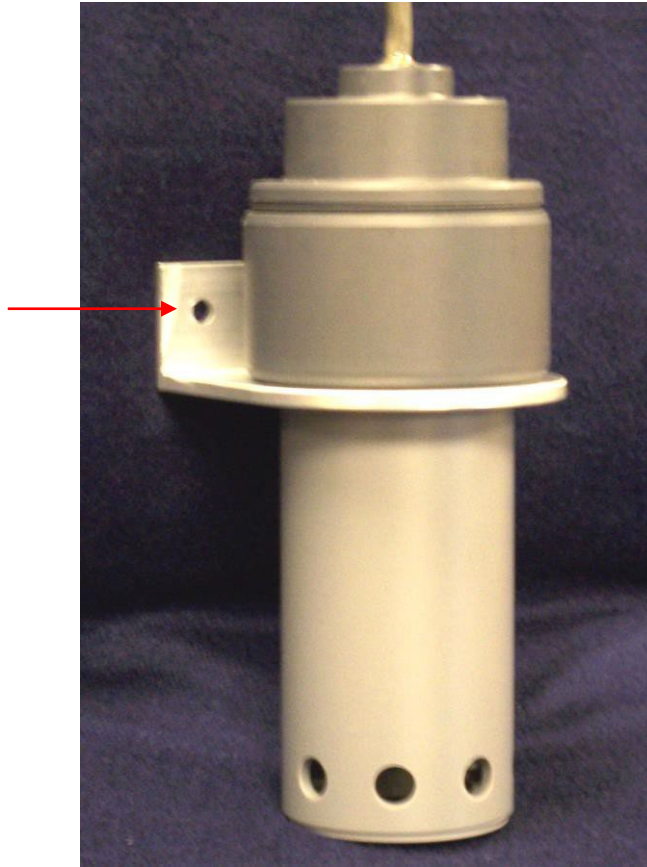

# DQS cell Mounted to AirCheck Lite



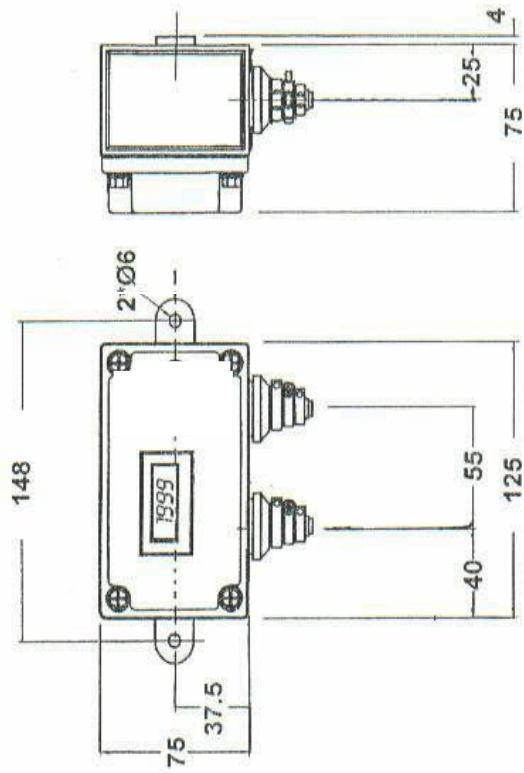

Dimensional information given in millimeters (mm).

TX-FHD Remote Transmitter Dimensions

SCALE:	APPROVED BY:	DRAWN BY: J Lund
DATE: Sept 3, 1998	<i>[Signature]</i>	REVISED
		DRAWING NUMBER
		TX-IJFHD

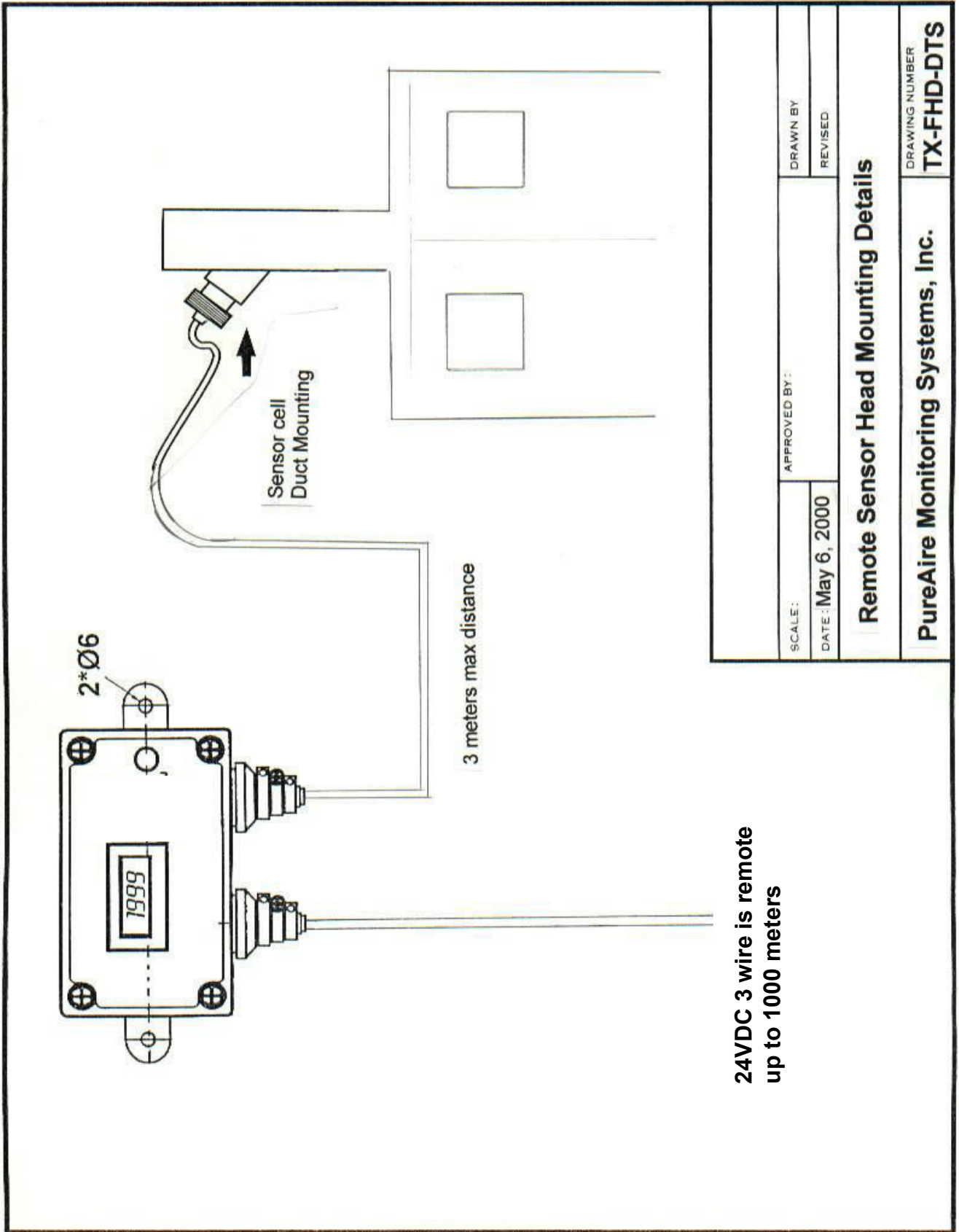

24VDC 3 wire is remote  
up to 1000 meters

SCALE:	APPROVED BY:	DRAWN BY:
DATE: May 6, 2000		REVISED:
<b>Remote Sensor Head Mounting Details</b>		
<b>PureAire Monitoring Systems, Inc.</b>		DRAWING NUMBER <b>TX-FHD-DTS</b>

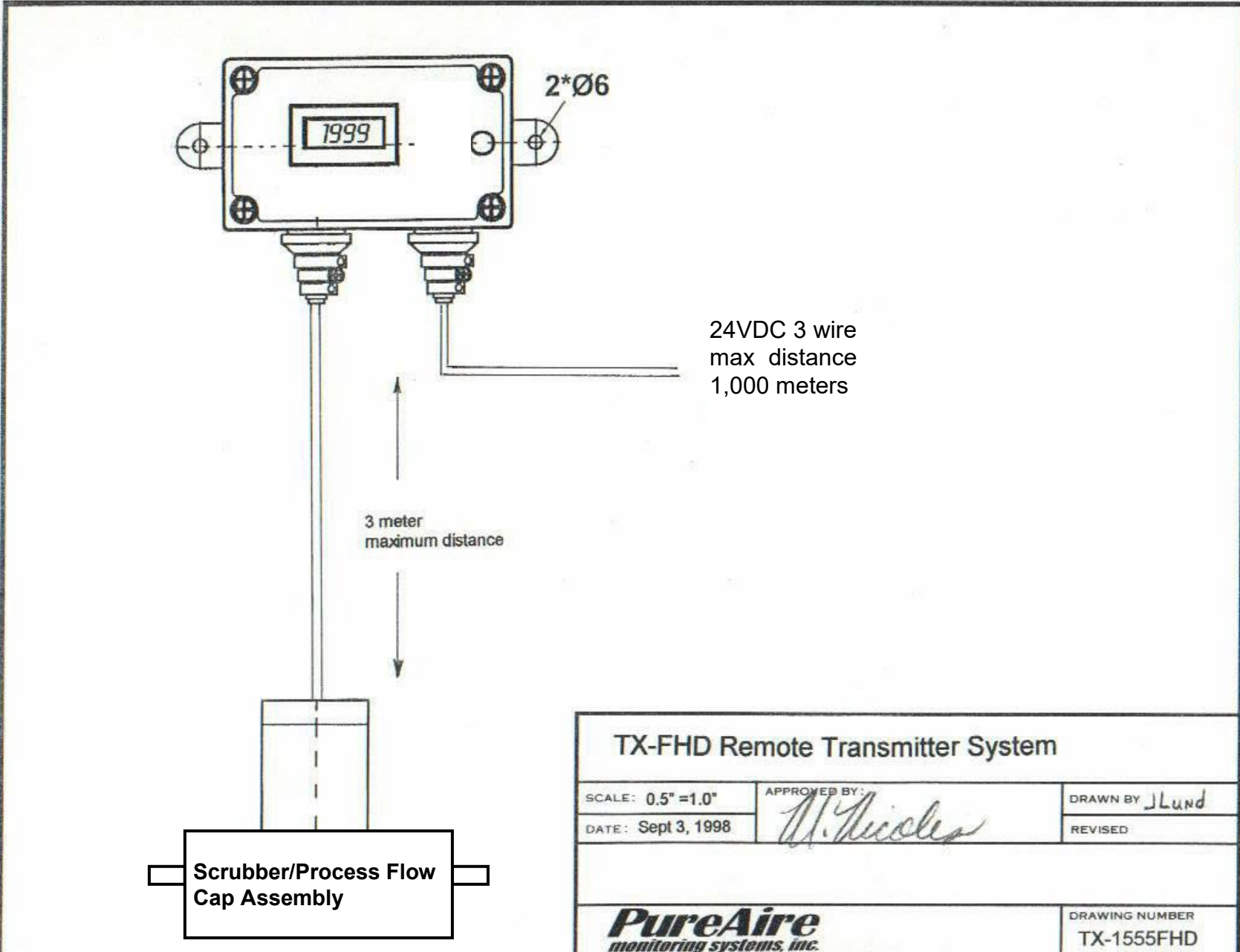

<b>TX-FHD Remote Transmitter System</b>		
SCALE: 0.5" = 1.0"	APPROVED BY: <i>W. Tucker</i>	DRAWN BY J.Lund
DATE: Sept 3, 1998		REVISED
<b>PureAire</b> <i>monitoring systems, inc.</i>		DRAWING NUMBER TX-1555FHD

## Exploded view of Vertical Bulkhead Fitting for Gas Cabinet & VMB

### Installation Instructions

**Note:** *The bulkhead holder is designed to mount the sensor cell on a vertical duct positioned at a 45° angle from vertical.*

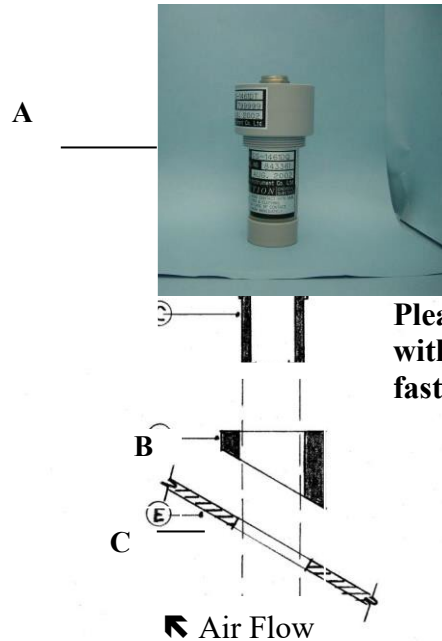

Cut a 2” hole in the duct wall, [C] mount Bulkhead mounting flange [B] to the duct wall with self-tapping screws.

Insert cell into the flange, [B] and fasten by turning the cell clockwise.

**Please note the sensor cell is labeled with the proper direction when fastened into the flange.**

<b>A</b>	Gas Sensor Cell Fastens directly into the sensor cell holder flange
<b>B</b>	Sensor cell holder Curved to fit the OD of duct.
<b>C</b>	Duct Wall – not more than 0.375 inches thick

**PureAire Monitoring Systems, Inc.**  
 557 Capital Drive Lake Zurich, Illinois 60047  
 Phone 888-788-8000 Fax: 847-726-6051  
 Email: [pureaire@dls.net](mailto:pureaire@dls.net)

Bulkhead Mount Vertical for Gas Cabinet and VMB  
 SCALE: None

DATE: Sept 17, 2003

## 7: Appendix

---

Ammonia (NH <sub>3</sub> )	0 to 75 ppm
Arsine (AsH <sub>3</sub> )	0 to 1 ppm
Boron Trichloride (BCl <sub>3</sub> )	0 to 9 ppm
Carbon Monoxide (CO)	0 to 100 ppm
Chlorine (Cl <sub>2</sub> )	0 to 3 ppm
Diborane (B <sub>2</sub> H <sub>6</sub> )	0 to 1 ppm
Fluorine (F <sub>2</sub> )	0 to 1 ppm
Hydrogen (H <sub>2</sub> )	0 to 4% vol
Hydrogen Bromide (HBr)	0 to 9 ppm
Hydrogen Chloride (HCl)	0 to 15 ppm
Hydrogen Fluoride (HF)	0 to 9 ppm
Hydrogen Sulfide (H <sub>2</sub> S)	0 to 30 ppm
Nitric Oxide (NO)	0 to 100 ppm
Nitrogen Dioxide (NO <sub>2</sub> )	0 to 9 ppm
Oxygen Deficiency (O <sub>2</sub> )	0 to 25%
Phosphine (PH <sub>3</sub> )	0 to 1 ppm
Silane (SiH <sub>4</sub> )	0 to 15 ppm

## Air Check 3 Lite Sensor cell

### Set up instructions

- 1) Remove the red shorting pin from the sensor cell PCB.
- 2) Connect the 5-pin Din connector on sensor cable to the connector on the sensor cell.  
**Note:** The connector is keyed and only inserts in one direction. Ensure proper alignment before seating the connector.
- 3) Twist the connector-locking ring onto the sensor cell.  
**Note:** When the cell is properly connected the Air Check 3 Lite digital display will and the internal green LED on the transmitter board will illuminate.

