

PureAire Monitoring Systems O₂ Deficiency Sample Draw Monitors

Instruction Manual

For models

US (99019/99029/99092/99059/99060)

Intl (99129/99130)

Water Resistant (99118)

Class I EXR (99020/99099/99132/99134)

Class II EXR (99045/99133)



PureAire Monitoring Systems, Inc.
1140 Ensell Road
Lake Zurich, Illinois 60047
Phone: +1 (847) 726-6000
Fax: +1 (847) 726-6051
Toll-Free: +1 (888) 788-8050
24/7 Emergency: +1 (224) 443-5445
Pureairemonitoring.com
Rev 5.07 April 2025

Welcome to PureAire Monitoring Systems

I would like to thank you for investing in our continuous life safety and process control toxic gas monitoring systems.

PureAire offers an unbeatable combination of experience and innovation in solving the safety and environmental needs of our customers. We can provide small systems of a few points, to a total multi-point turnkey computerized package.

PureAire's proprietary sensor cell technology and state-of-the-art electronics are designed to interface with the latest distributive or PLC based control systems. We believe that our experience, innovative products, and commitment to service will satisfy your specific monitoring needs now, and in the future.

Our growth is a result of our total commitment to supporting our customers. We are available 24 hours a day, 7 days a week to help you when you need us. Our 24-hour Emergency phone number is +1 (224) 443-5445. We can provide field service recommendations, preventative maintenance programs and training to your technicians in the operation of our equipment. Our goal is to provide the best after-sales service and support in the industry. That is just one way PureAire takes that extra step to ensure your complete satisfaction.

Thank you again for investing in PureAire Monitoring Systems for your monitoring needs and I am proud to welcome you to our family of valued and satisfied customers.

Sincerely,

Albert A. Carrino

President

PLEASE READ BEFORE INSTALLATION

The following environmental conditions **WILL DAMAGE** the Oxygen Monitor

1. The PureAire Monitor requires **24 VDC regulated power ONLY**. **DO NOT** connect the monitor to >24 VDC, or **ANY AC Voltage**.
2. **DO NOT power** the monitor **without the sensor attached** to the main assembly. **DO NOT disconnect/reconnect sensor** while monitor is powered.
3. Each sensor cell is matched specifically to each monitor. **NEVER exchange sensors and monitors**.
4. Flows rates above **500 cc/min (0.5 LPM)** may lead to inaccurate readings. Flow rates **above 1 LPM will cool the sensor** and yield inaccurate readings.
5. **Calibration gases** should be blends consisting of **Oxygen and Nitrogen ONLY**. DO NOT expose the monitor to any combustible gas (Methane, Hydrogen, etc.). **Combustible gas exposure will quickly damage the cell**.
6. **NEVER expose** the sensing element to compounds consisting of **Silicone, Freon, or corrosive compounds**. Exposure will quickly, **irreversibly damage** the cell causing an extreme loss in sensitivity.
7. When using the monitor, DO NOT expose the oxygen sensor directly to a water stream. In areas requiring wash downs, cover and protect the monitor and power supply. Contact PureAire for details on waterproof enclosures.

The Password for entering the menus is 557.

Table of Contents

PureAire Monitoring Systems O ₂ Deficiency Sample Draw Monitors	1
1: Introduction.....	7
1.1 Key Features	7
1.1.1 Long Life Zirconium Oxide O ₂ Sensor.....	7
1.1.2 Smart Electronics	8
1.1.3 Sensor Adjustment	8
1.1.4 Factory Reset	8
1.1.5 AutoSpan Function	8
1.2 Component Identification	8
1.2.1 Sample Draw Oxygen Monitors	8
1.2.2 Sample Draw Oxygen Monitors (Hornless)	9
1.2.3 Sample Draw Oxygen Monitors (Pumpless)	10
1.2.4 Water Resistant Sample Draw Monitors.....	10
1.2.5 Class I Explosion Proof Monitor	11
1.2.6 Class II Explosion Proof Monitor.....	11
1.2.7 Particulate Filter Assembly.....	12
1.2.8 Water/Humidity Filter Assembly.....	12
1.2.9 Joystick Board.....	13
1.2.10 Relay Board	13
2: Specifications.....	14
2.1 Performance Specifications	14
2.2 Operating Conditions	14
2.2.1 Sample Draw Oxygen Detector	14
2.2.2 Water Resistant Sample Draw Oxygen Detector.....	14
2.2.3 Class I Explosion Proof Oxygen Detector	14
2.2.4 Class II Explosion Proof Oxygen Detector.....	14
2.3 Gas Detection System.....	15
2.4 Electrical Requirements	15
2.5 Physical Characteristics	16
2.5.1 Sample Draw Oxygen Detector	16
2.5.2 Water Resistant Sample Draw Oxygen Detector.....	16
2.5.3 Class I Explosion Proof Oxygen Detector	16
2.5.4 Class II Explosion Proof Oxygen Detector.....	16

2.5.5	Class I Explosion Proof Oxygen Detector	16
2.5.6	Class II Explosion Proof Oxygen Detector.....	16
2.6	Default Factory Settings	17
3:	Installation	18
3.1	Site Requirements	18
3.2	Mounting.....	19
3.2.1	Sample Draw Monitor Enclosure Dimensions	19
3.2.2	Water-Resistant Sample Draw Monitor Enclosure Dimensions.....	19
3.2.3	Explosion-Proof Class I Enclosure Dimensions (99020/99099 – Discontinued). 20	
3.2.4	Explosion-Proof Class II Enclosure Dimensions (99045 – Discontinued).....	20
3.2.5	Explosion-Proof Class I Enclosure Dimensions (99132/99134)	21
3.2.6	Explosion-Proof Class II Enclosure Dimensions (99133)	21
3.2.7	Sample Inlet Filter.....	22
3.2.7.1	Dust & Particulate Filter	22
3.2.7.2	<i>Humidity/Water Filter</i>	23
3.2.8	Installation Guidance	23
3.3	Wiring	24
3.3.1	Power to Monitor	24
3.3.2	Relay Board Connections	24
4:	Normal Operation	25
4.1	Signal Outputs.....	25
4.2	Instrument Faults	25
4.3	Routine Maintenance Schedule.....	25
4.4	Loss of Power Indication	26
4.5	Alarm Reset	26
5:	Monitor Programming	27
5.1	Joystick Operation	27
5.2	Hall Board/Magnetic Wand Operation	28
5.3	Overall Program Flowchart.....	29
5.3.1	Top Level Menu Navigation.....	29
5.4	Entering Password	30
5.5	Changing the User Password	30
5.6	Setting 4-20mA Loop	31
5.7	Setting Relay Formats.....	31

5.8	Setting Alarm Polarity	32
5.9	Setting Alarm Latching.....	33
5.10	Sensor Adjustment Menus	34
5.11	AutoSpan Menus.....	35
5.12	Factory Reset Menus.....	36
5.13	Setting Alarm Hysteresis	37
5.13.1	Hysteresis.....	37
5.14	Setting Alarm Thresholds	38
5.15	Setting Alarm Delay	39
6:	Maintenance & Sensor Verification	40
6.1	Setting Alarm Delay	40
6.1.1	Sensor Verification Gas	40
6.1.2	Sensor Verification Equipment.....	40
6.2	Sensor Functionality Verification Procedure.....	40
6.3	Ambient Oxygen Level Verification	41
6.4	AutoAdjust Functions	42
6.4.1	Monitor AutoSpan	42
6.4.2	Reset AutoCal to Factory Settings.....	43
6.5	Manual Monitor Span Adjustment.....	43

1: Introduction

The Air Check O₂ Deficiency Monitor is a compact and efficient system for continuous oxygen level monitoring in confined spaces or areas with inert gases. Unaffected by fluctuating temperature or humidity levels, the device's robust zirconium sensor provides accurate and stable oxygen readings. Suitable for both indoor and outdoor use, the monitor is factory calibrated against NIST standards and carries UL, CUL, and Ce certifications.

The system's centerpiece is a durable zirconium sensor that reacts quickly to low oxygen levels, offering precise measurements across a broad temperature and humidity spectrum. Designed for minimal maintenance, this sensor is expected to work seamlessly for **10+ years**, and unlike disposable sensors, it eliminates the need for frequent calibration, **with no zero or span pots**, saving significant maintenance time and costs.

Each Air Check O₂ Sample Draw Monitor system consists of a resilient zirconium oxide sensor cell and a three-wire transmitter. The monitor, capable of operating as a stand-alone gas detector, can also be incorporated with PureAire's single or multi-point controllers, or a comprehensive centralized control system. Importantly, the performance and accuracy of the monitor remain consistent irrespective of the prevailing weather or temperature conditions.

A defining aspect of the monitor is its Sensor Housing Assembly, designed to facilitate pass-through or internally drawn samples. Included as a standard feature is a sample pump, although it is optional, capable of drawing at a rate of **250 ccs/min or 0.25 LPM**. Similarly, the audio alarm, while standard, is optional and can be tailored as per your needs.

The sample pump has a **maximum draw distance of 100 ft**, providing flexibility in monitoring locations. The electrical components of the monitor are securely housed in a **standard NEMA 3** enclosure. Optional upgrades include an IP67 water-resistant enclosure, or Class I or Class II explosion-proof housing, depending on your specific requirements. This manual will offer detailed instructions on the installation, operation, and maintenance of the Air Check O₂ Sample Draw Monitor.

1.1 Key Features

The Air Check O₂ Deficiency Monitor is designed with an array of innovative features that facilitate ease of use and efficient operation. These unique characteristics have been thoughtfully incorporated to streamline the installation process, optimize daily functionality, and minimize maintenance needs. By fusing cutting-edge technology with user-centric design, the monitor delivers reliable performance while ensuring a simplified user experience.

1.1.1 Long Life Zirconium Oxide O₂ Sensor

The Air Check O₂ Deficiency Monitor features a durable zirconium oxide O₂ sensor with over 10 years of continuous operation life. Uniquely designed by PureAire, this sensor can accurately detect low oxygen levels in confined spaces and process tools without needing a reference gas, setting it apart from conventional concentration O₂ cells.

1.1.2 Smart Electronics

The monitor integrates a specialized electronic circuit to continuously oversee the sensor's operation. This advanced circuitry can promptly identify any sensor degradation or failure, alerting the user to any sensor faults or electrical issues that might disrupt surveillance via the standard mA signal output or the optional fault relay.

1.1.3 Sensor Adjustment

The device uses a stable zirconium oxide sensor that requires minimal adjustment. Environmental factors like changes in barometric pressure, temperature, and humidity do not affect the sensor's performance. It can easily visually verify the Earth's 20.9% oxygen level under ambient conditions, without the need for any zero or span pot adjustments. Periodic nitrogen testing is all that's needed to verify the cell's response to low oxygen levels.

1.1.4 Factory Reset

Introduced in the Version 5.0 update, the factory reset feature allows users to return the monitor to its original state as per the factory calibration certificate, enhancing the usability and convenience of the system.

1.1.5 AutoSpan Function

Also added in the Version 5.0 update, the AutoSpan function enables automatic span adjustment to 20.9% oxygen, eliminating the need for manual adjustments and further simplifying the user's experience.

Further details about the factory reset and AutoSpan function will be provided later in the manual.

1.2 Component Identification

1.2.1 Sample Draw Oxygen Monitors

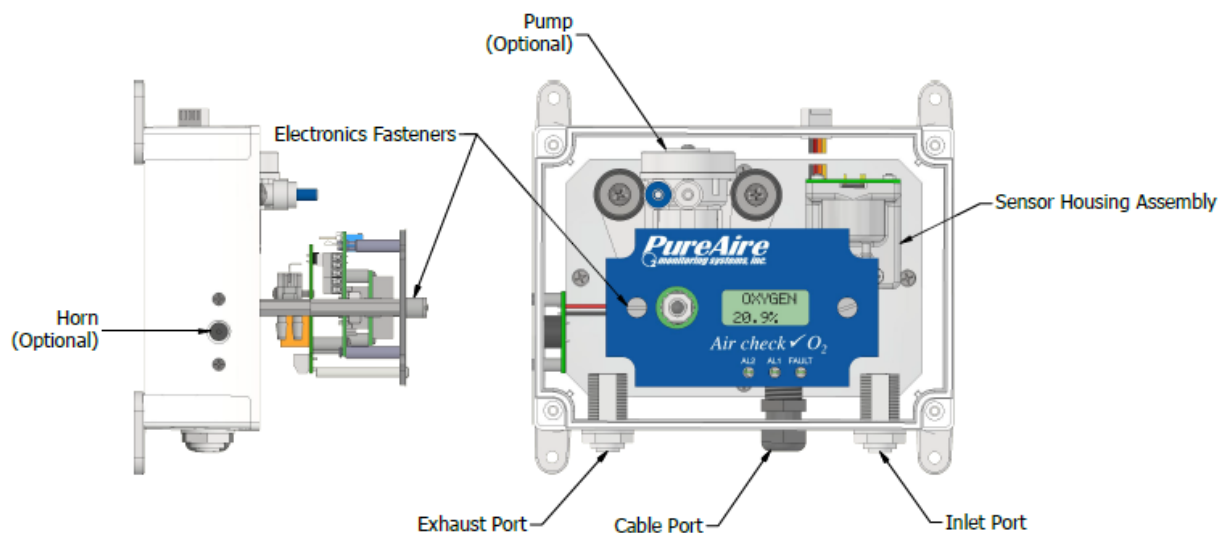

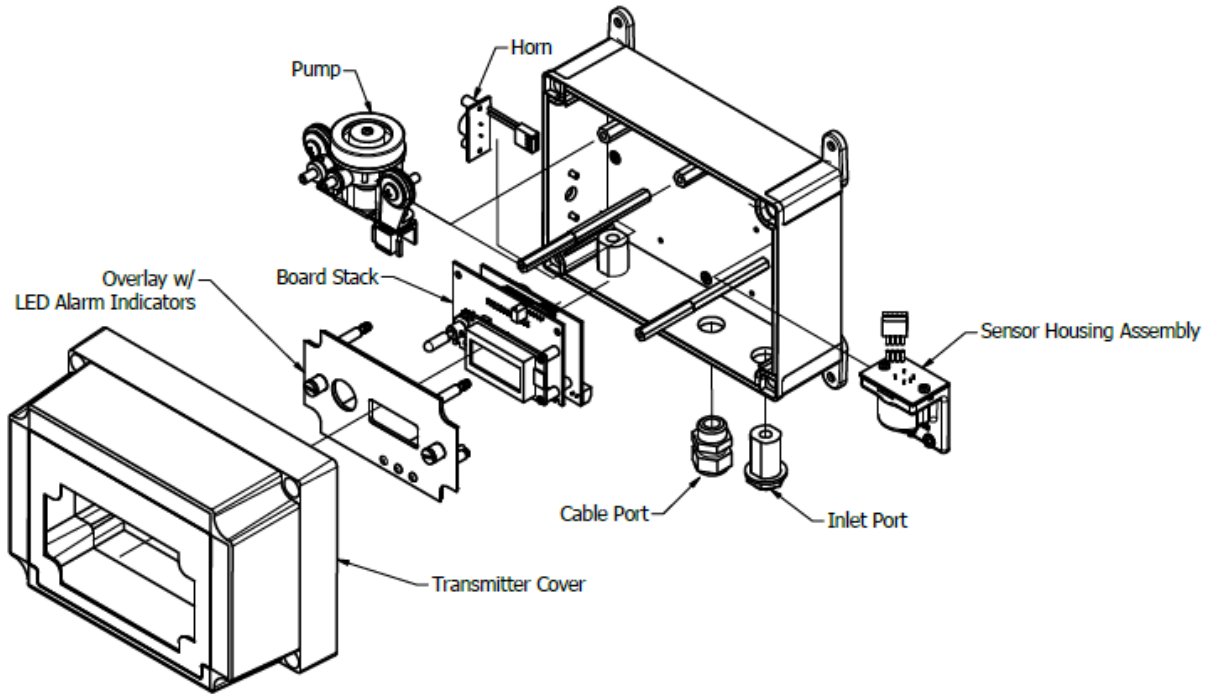

1.2.2 Sample Draw Oxygen Monitors (Hornless)

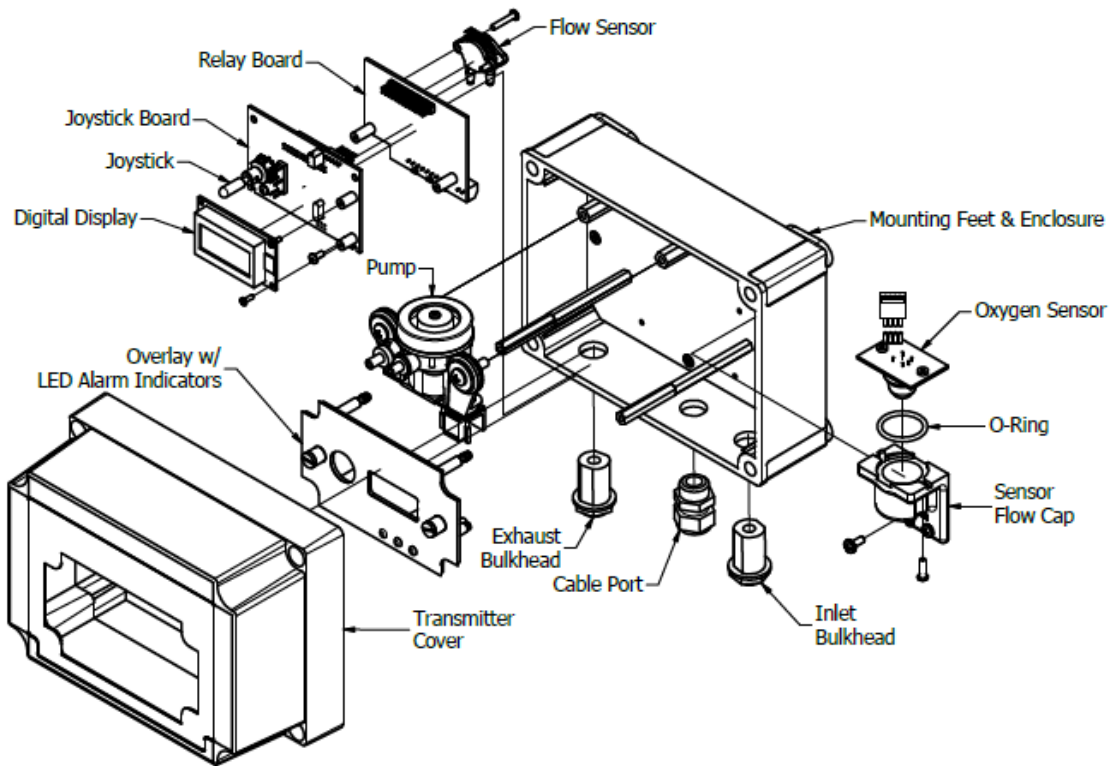

1.2.3 Sample Draw Oxygen Monitors (Pumpless)

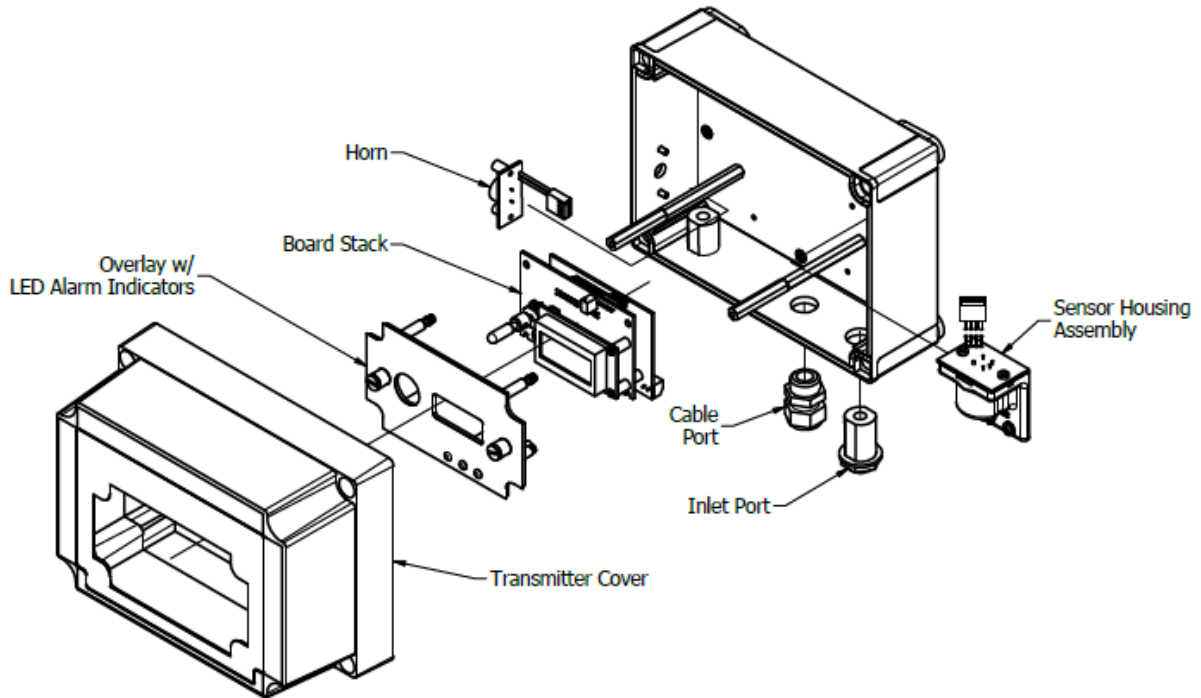

1.2.4 Water Resistant Sample Draw Monitors

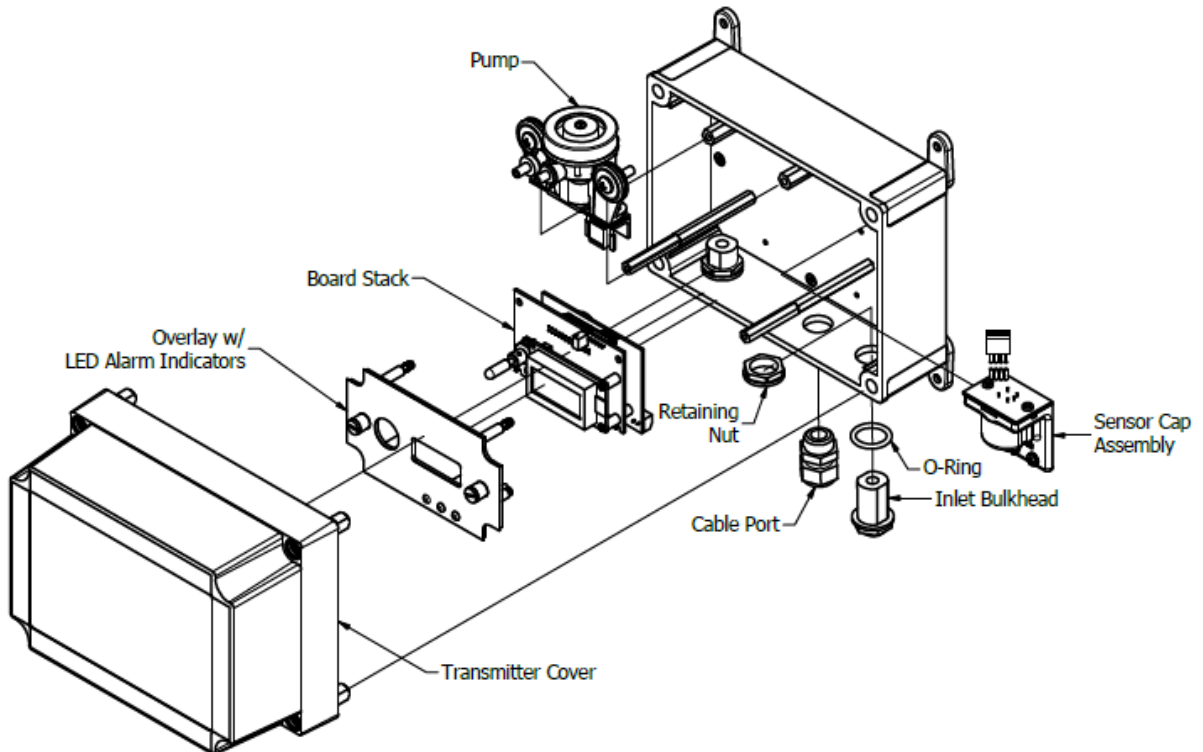

1.2.5 Class I Explosion Proof Monitor

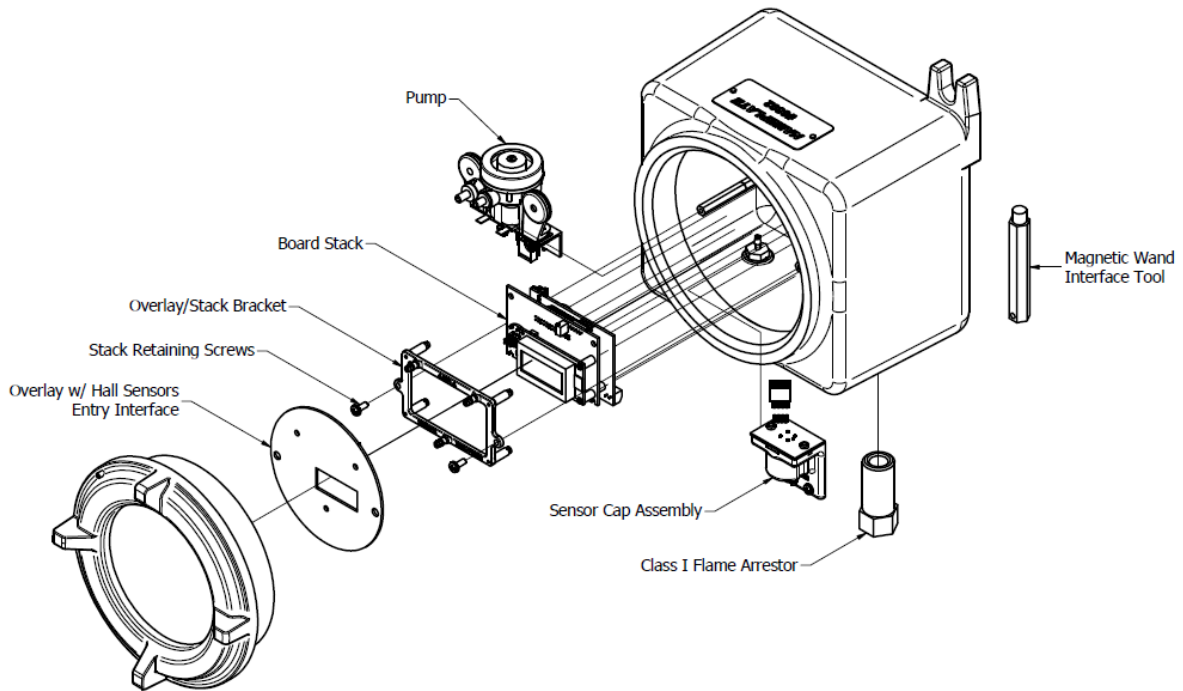

1.2.6 Class II Explosion Proof Monitor

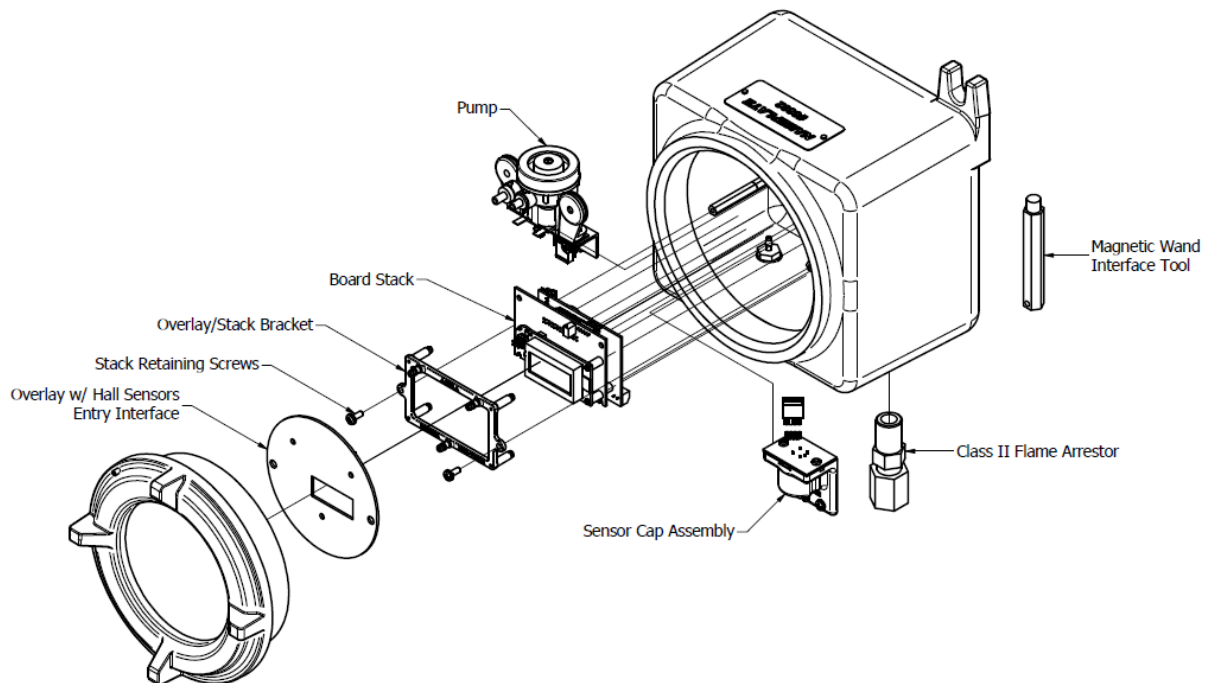

1.2.7 Particulate Filter Assembly

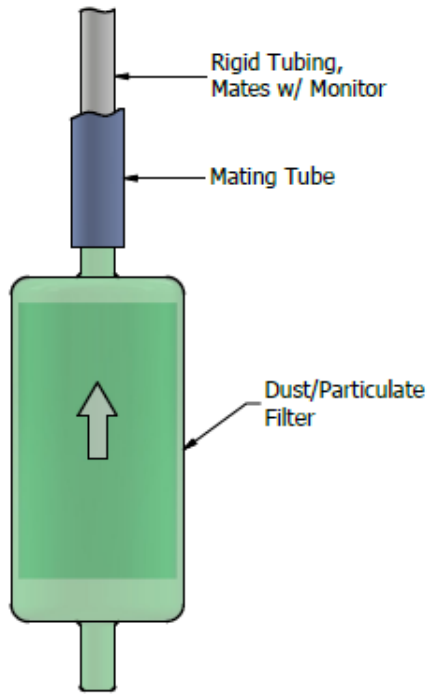

1.2.8 Water/Humidity Filter Assembly

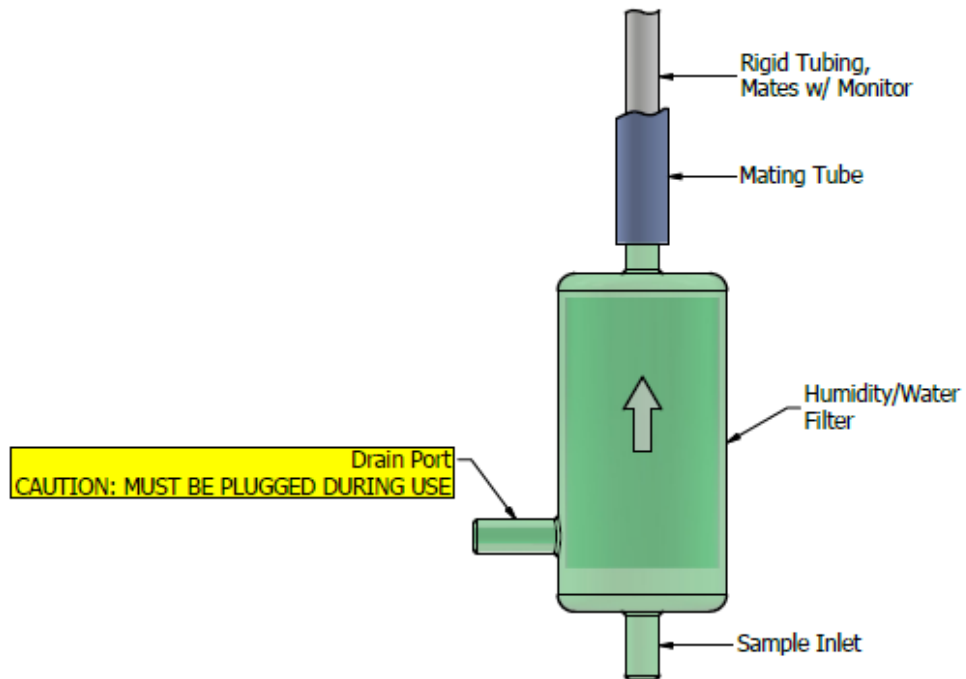

1.2.9 Joystick Board

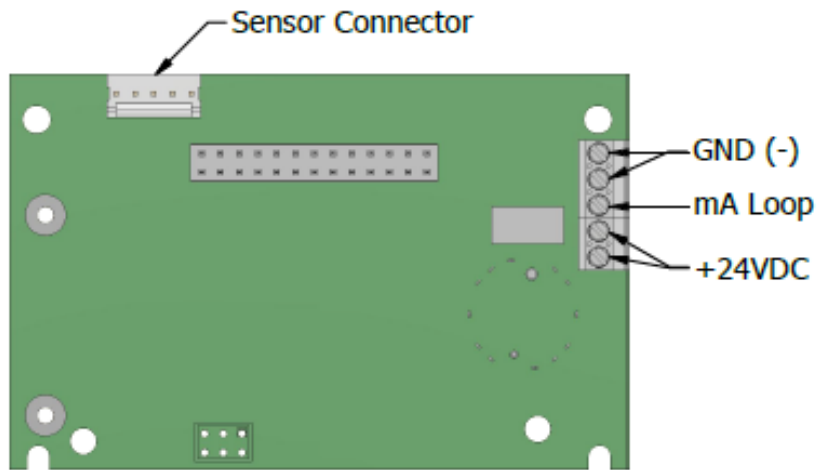

1.2.10 Relay Board

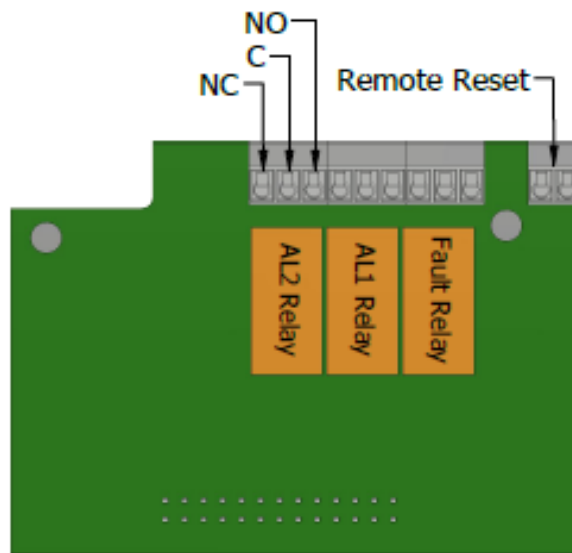

NC: Normally Closed
C: Common
NO: Normally Open

2: Specifications

NOTE: For our continual product improvement, all specifications are subject to change without notice

2.1 Performance Specifications

Sensor Type:	Long-Life Zirconium Oxide Sensor Cell.	0-25%/0-30%/0-95%
Response Time:	Swift response within 1 second to any O2 level change.	
Accuracy:	Delivers ±0.2% O2 accuracy. (±1% of full range)	
Fault Indicators:	Loss of VDC power (analog signal drops to 0 mA). Sensor cell failure: Fault relay activated.	
Operating Cond.:	-40° to 134°F (-40° to 55°C) 0 to 95% RH (Standard) Up to 100% RH, Water Resistant Enclosure, w/o horn (99118 only) Class 1, Div 1 & 2, Groups B, C, D, Zones 1 & 2, Groups IIB+H2, IIA (99020/99099/99132/99134) Class 2, Div 1 & 2, Groups E, F, G, Class III, Type 4 & 4X. ATEX, IEC Ex, Ex d IIC, IP66 (99045/99133)	
UL/CUL Listing:	Measuring Equipment E363306	
Ce:	EN 61000-3-2:2006 EMC, EN 61000-3-3:2008 EMC, EN61010-1-3-2013 LVD	

2.2 Operating Conditions

2.2.1 Sample Draw Oxygen Detector

Product Lines:	Standard
Temperature:	-40° to 40°C (-40° to 104°F); Consult PureAire for extended ranges.
Rel. Humidity:	0 to 95% RH; NEMA 3 enclosure.

2.2.2 Water Resistant Sample Draw Oxygen Detector

Product Lines:	99118
Temperature:	-40° to 40°C (-40° to 104°F); Consult PureAire for extended ranges.
Rel. Humidity:	0 to 100% RH; IP67 water resistant enclosure.

2.2.3 Class I Explosion Proof Oxygen Detector

Product Lines:	99020/99099/99132/99134
Temperature:	-40° to 55°C (-40° to 134°F); Consult PureAire for extended ranges.
Rel. Humidity:	0 to 95% RH; Explosion proof designed for installation in Class I, Div. 1&2, Groups B, C, and D, Zones 1&2, Groups IIB+H2, IIA hazardous areas.

2.2.4 Class II Explosion Proof Oxygen Detector

Product Lines:	99045/99133
Temperature:	-40° to 55°C (-40° to 134°F); Consult PureAire for extended ranges.
Rel. Humidity:	0 to 95% RH; Explosion Proof designed for installation in Class II, Groups E, F, and G, Class III, Type 4 & 4X. ATEX, IEC Ex, Ex d IIC, IP66.

2.3 Gas Detection System

Type and Life:	Long-Life Zirconium Oxide Sensor cell with a lifespan of 10+ years under normal conditions.
Transmitter:	Features a microprocessor with a built-in 3-digit backlit LCD display and joystick-operated menus for easy navigation.

2.4 Electrical Requirements

Power:	24VDC external power. A regulated 24VDC power supply is required.
Consumptions:	Approx. 250mA

2.5 Physical Characteristics

2.5.1 Sample Draw Oxygen Detector

Product Lines: **Standard**
Dimensions: 7.0 (W) x 5.0 (H) x 5.0 (D) inches; 178 x 127 x 127 mm
Weight: 4 pounds (2 kg)
Enclosure Type: General purpose NEMA 3 housing; not intended for explosive atmospheres.

2.5.2 Water Resistant Sample Draw Oxygen Detector

Product Lines: **99118**
Dimensions: 7.0 (W) x 5.0 (H) x 5.0 (D) inches; 178 x 127 x 127 mm
Weight: 4 pounds (2 kg)
Enclosure Type: Polycarbonate IP67 water resistant; not intended for explosive atmospheres.

2.5.3 Class I Explosion Proof Oxygen Detector

Product Lines: **99020/99099 – Discontinued**
Dimensions: 6.625 (W) x 5.50 (H) x 5.25 (D) inches; 168 x 140 x 134 mm
Weight: 12 pounds (5.5 kg)
Enclosure Type: Explosion proof housing designed for installation in Class I, Div 1&2, Groups BCD, Zones 1&2, Groups IIB+H2, IIA hazardous areas.

2.5.4 Class II Explosion Proof Oxygen Detector

Product Lines: **99045 – Discontinued**
Dimensions: 6.625 (W) x 5.50 (H) x 5.25 (D) inches; 168 x 140 x 134 mm
Weight: 12 pounds (5.5 kg)
Enclosure Type: Explosion proof housing designed for installation in Class II, Div 1&2, Groups EFG, Class III, Type 4 & 4X. ATEX, IEC Ex, Ex d IIC, IP66.

2.5.5 Class I Explosion Proof Oxygen Detector

Product Lines: **99132/99134**
Dimensions: 7.56 (W) x 10.00 (H) x 6.69 (D) inches; 192 x 254 x 170 mm
Weight: 12 pounds (5.5 kg)
Enclosure Type: Explosion proof housing designed for installation in Class II, Div 1&2, Groups BCD, Zones 1&2, Groups IIB+H2, IIA hazardous areas.

2.5.6 Class II Explosion Proof Oxygen Detector

Product Lines: **99133**
Dimensions: 7.56 (W) x 10.00 (H) x 6.69 (D) inches; 192 x 254 x 170 mm
Weight: 12 pounds (5.5 kg)
Enclosure Type: Explosion proof housing designed for installation in Class II, Div 1&2, Groups EFG, Class III, Type 4 & 4X. ATEX, IEC Ex, Ex d IIC, IP66.

2.6 Default Factory Settings

The Air Check O2 Monitor is shipped with factory defaults that are saved to the memory of the unit. Factory resettable functions are denoted by †.

Menu	Factory Default	Definition
Set 4-20mA Loop†	mA output is individually set at the factory using a calibrated Fluke meter.	Use this function to adjust the Oxygen monitors 4 mA (Zero), and 20 mA (Span) analog output
Set Formats†	Alarm 1 = Normal Alarm 2 = Normal Fault = Normal	When alarm activates, the relays should energize (Normal), or de-energize (Inverted)
Set Polarity†	Alarm 1 = Inverted Alarm 2 = Inverted Audio = Inverted*	Alarm should activate above specified concentration (Normal), or when lower (Inverted) than the alarm thresholds
Set Latching†	Alarm 1 = Non-latching Alarm 2 = Non-latching Fault = Non-latching	Automatic alarm reset (non-latching), or manual alarm reset (latching)
Alarm Delay†	Alarm = 5 Seconds	Delay until alarm is activated
Zero Suppression	—	NOT ENABLED ON O2 MONITOR
Set Alarm Thresholds†	Alarm 1 = 19.5% Alarm 2 = 18.0% Audio = 19.5%*	Alarm levels
Set Alarm Hysteresis†	Alarm 1 = 0.0% Alarm 2 = 0.0% Audio = 0.0%*	Deadzone setting, more information in Section 5
Sensor Adjustment†	Monitors are individually calibrated at the factory using NIST traceable gas mixtures	For manual span adjustment or dynamic calibration (w/ known span gas) of Oxygen monitor
Manage Passwords	Factory Default is 557	For changing the password from factory default to a new password

*NOTE: The Audio alarm feature is optional

The LED indicators on the front panel are connected directly to the alarm relays.

3: Installation

3.1 Site Requirements

The Air Check O₂ Sample Draw Monitor is a sensitive piece of equipment and requires strategic placement to function optimally. Select an installation site that is free from extreme vibration, electrical noise or interference, high temperatures, or areas with a high likelihood of condensing humidity.

Consider installing the monitor at an elevated position that facilitates easy operation, maintenance, and display visibility. It should be mounted a minimum of 12 inches from the floor level and maintain a clearance of at least 3.75 inches for the inlet dust filter, a critical component that extends the lifespan of the device.

The monitor incorporates an internal sample pump, factory-set at a rate of 250 cc/min (0.25 LPM), which cannot be adjusted in the field. An onboard flow sensor continually observes the flow rates and triggers a fault mechanism, which includes the activation of a front-mounted LED and a fault relay, should the flow rate deviate from the set standard.

The pump responds dynamically to potential blockages in the sample line; it accelerates to restore the proper flow rate when a blockage is detected, and the fault indicator illuminates. If the obstruction is removed, the pump adjusts its speed accordingly, and the fault light deactivates once the flow rate is back to the factory-prescribed settings.

We suggest using polypropylene sample tubing with dimensions of 1/4" OD by 3/16" ID for optimal results. To maintain sample integrity, ensure that the tubing is of low permeability. Note that the monitor is designed to draw samples from distances ranging from 3-100 feet, and the total length of the tubing should not exceed 100 feet. Please consider lag time proportional to the distance of tubing for changes in oxygen readings.

NOTE: Pump is optional. For pumpless models, there will be no indication of flow faults.

CAUTION: ONLY CLASS I (99020/99099/99132/99134) & CLASS II (99045/99133) ENCLOSURES ARE RATED FOR HAZARDOUS LOCATIONS.

3.2 Mounting

3.2.1 Sample Draw Monitor Enclosure Dimensions

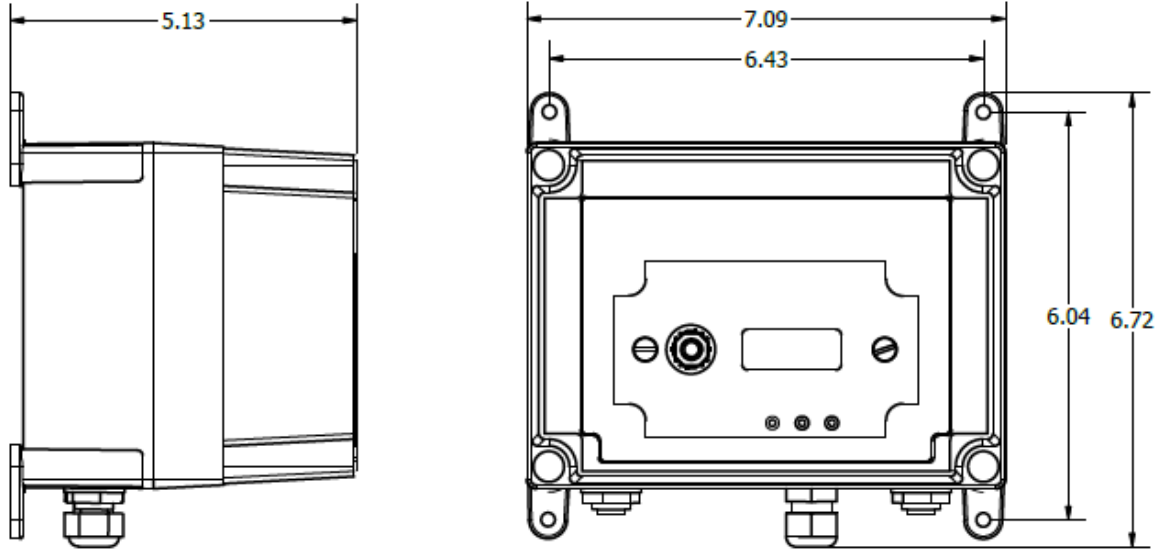

3.2.2 Water-Resistant Sample Draw Monitor Enclosure Dimensions

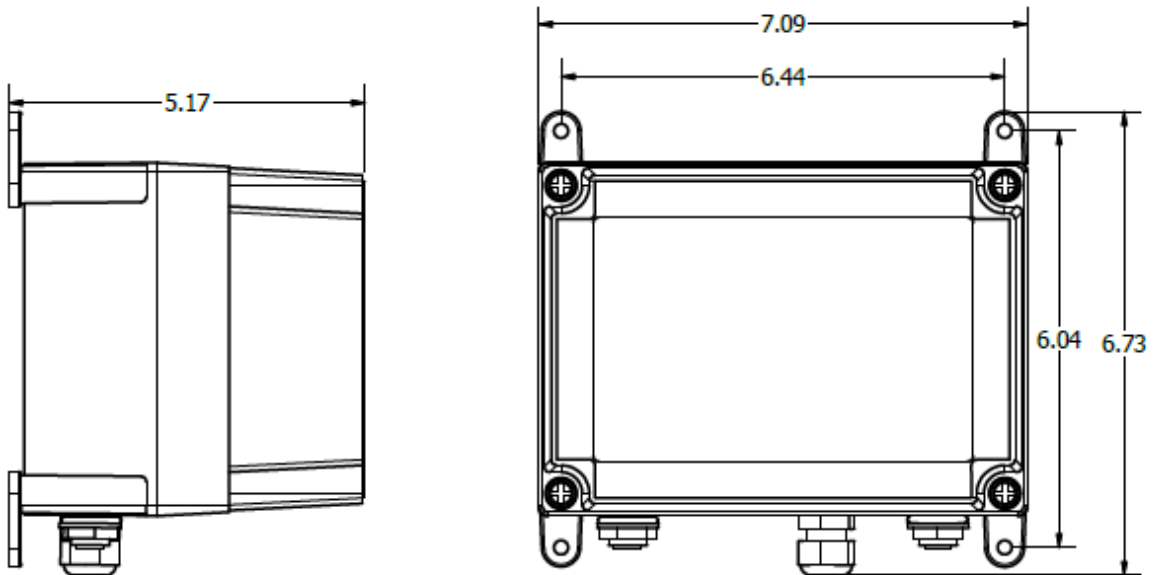

3.2.3 Explosion-Proof Class I Enclosure Dimensions (99020/99099 – Discontinued)

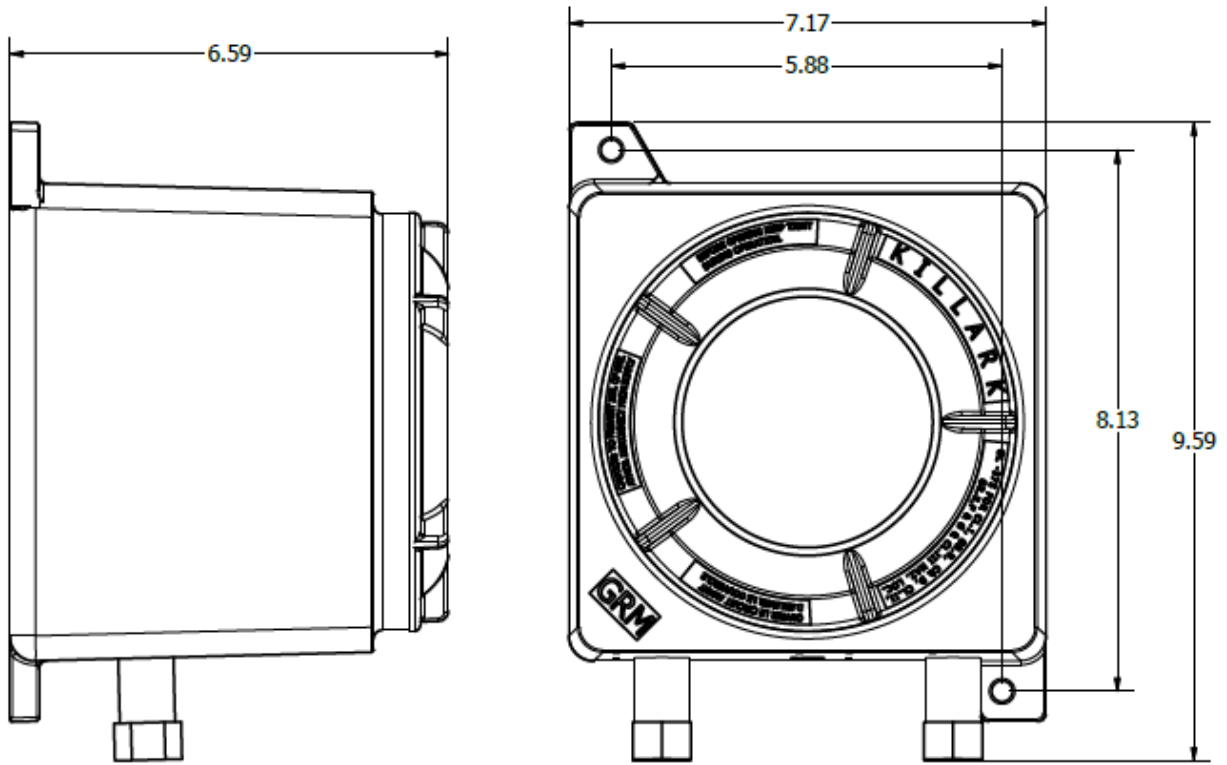

3.2.4 Explosion-Proof Class II Enclosure Dimensions (99045 – Discontinued)

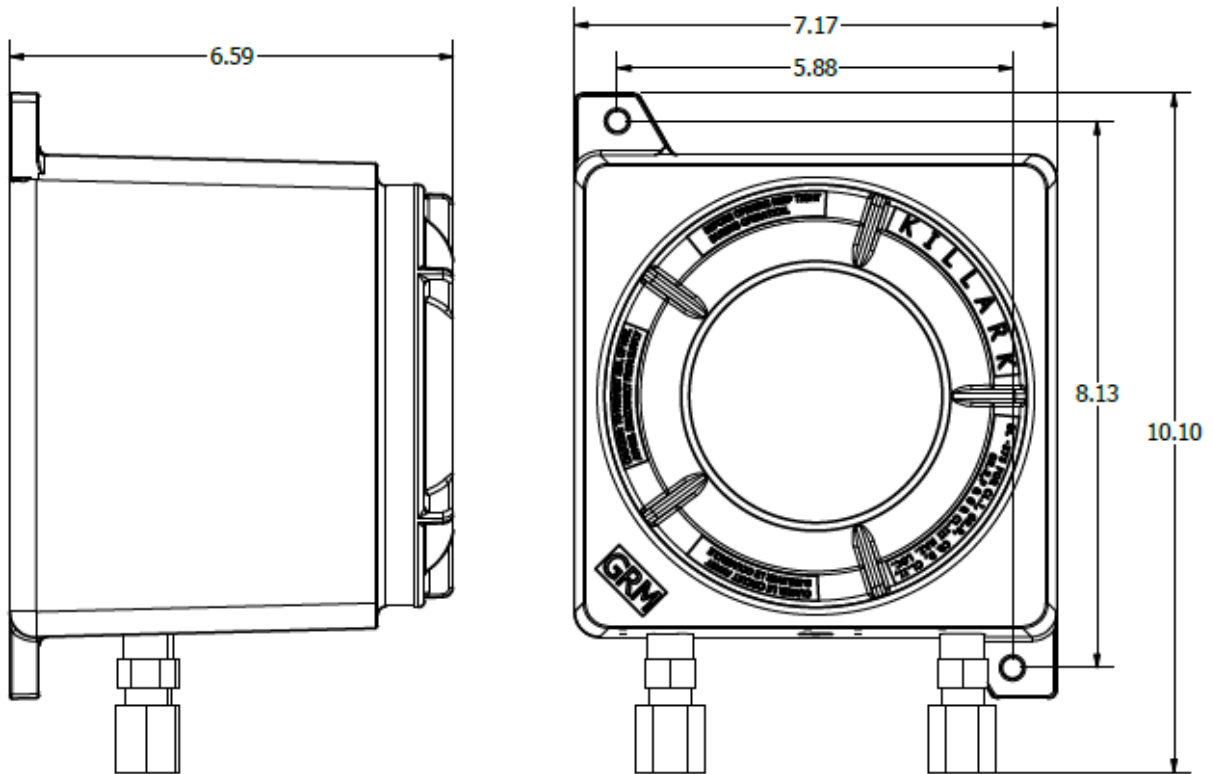

3.2.5 Explosion-Proof Class I Enclosure Dimensions (99132/99134)

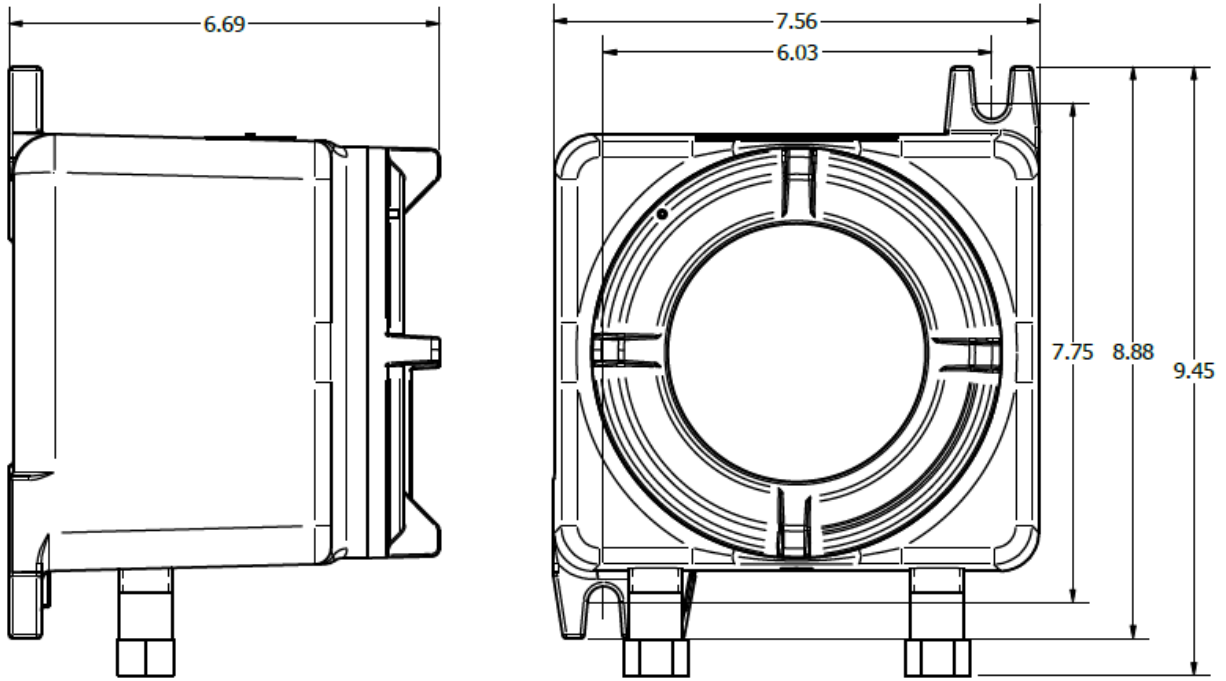

3.2.6 Explosion-Proof Class II Enclosure Dimensions (99133)

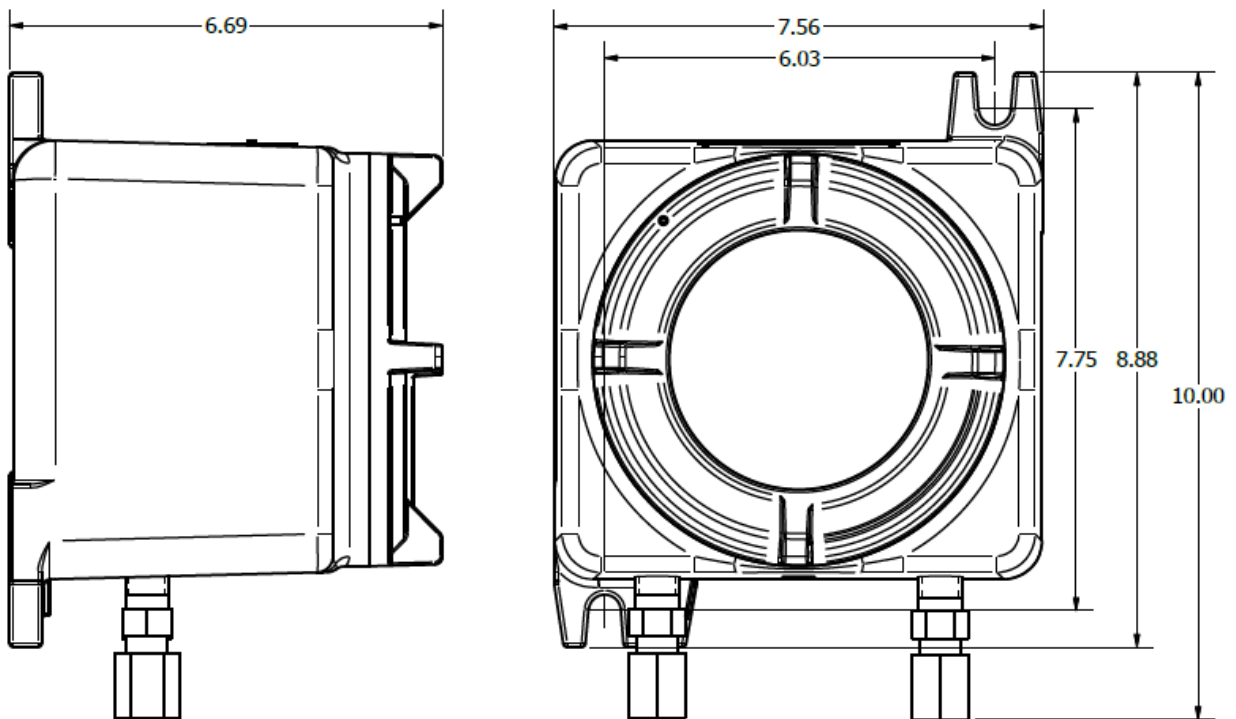

3.2.7 Sample Inlet Filter

3.2.7.1 Dust & Particulate Filter

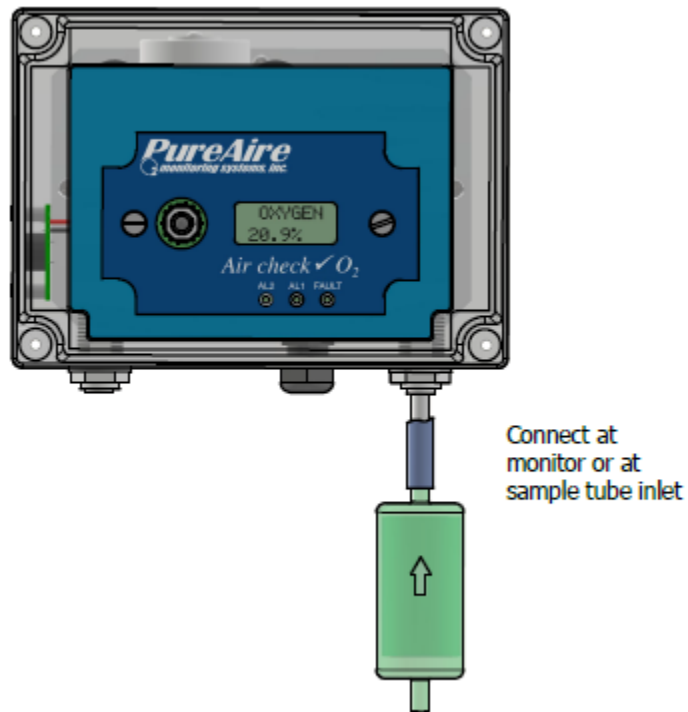

Depending on the environment, it is recommended that the filter be replaced every 12 months. In dusty environments, filter replacement may be more frequent.

For replacement dust/particulate filters, please order PureAire P/N 90115.

3.2.7.2 Humidity/Water Filter

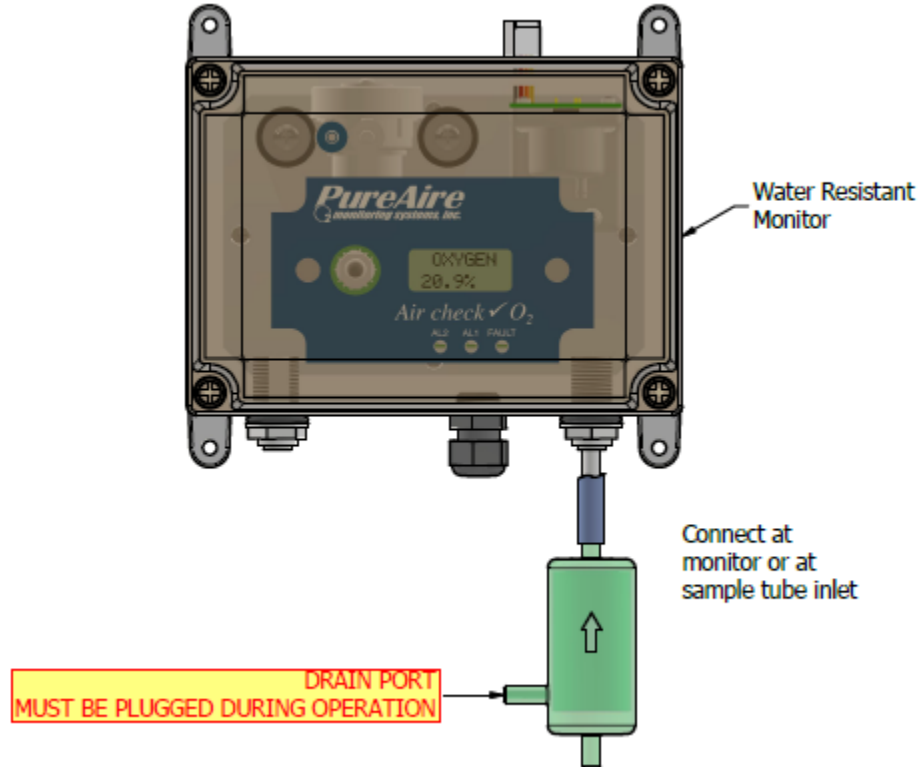

NEVER CONNECT ANY TUBING TO EITHER PORT. CONNECTIONS MAY ONLY BE MADE BETWEEN THE MONITOR AND THE FILTER WITH EACH ACTING AS AN ENDPOINT.

Depending on the environmental conditions, it is recommended that the filter be replaced every 12 months. To drain filter of moisture, unplug and drain through the marked drain port.

For replacement humidity/water filters, please order PureAire P/N 90179.

3.2.8 Installation Guidance

The Air Check sample draw monitor is designed primarily for wall mounting and should be installed at a height convenient for operation, maintenance, and viewing of the instrument's digital display.

Choose a location for sampling where potential gas leaks could occur or where any released gases might tend to gather. The installation should not be less than 12 inches above the floor level. **Consider factors such as air circulation patterns within the area to be sampled from, the properties of the gas (whether it's lighter or heavier than air), and the placement of workstations and staff when deciding on the optimal installation site.**

3.3 Wiring

The Air Check O₂ monitor necessitates a singular, triple-conductor shielded cable for the purpose of analog output and 24 VDC power input. It's recommended to employ a three-wire shielded cable, ideally of 18 AWG stranded, such as the General Cable E2203S.30.860 or an equivalent. The connections for analog output and VDC power input are to be made on the internal terminal block located within the transmitter housing.

Note that all PureAire monitors, except for explosion proof monitors, come with a plug-in power supply.

3.3.1 Power to Monitor

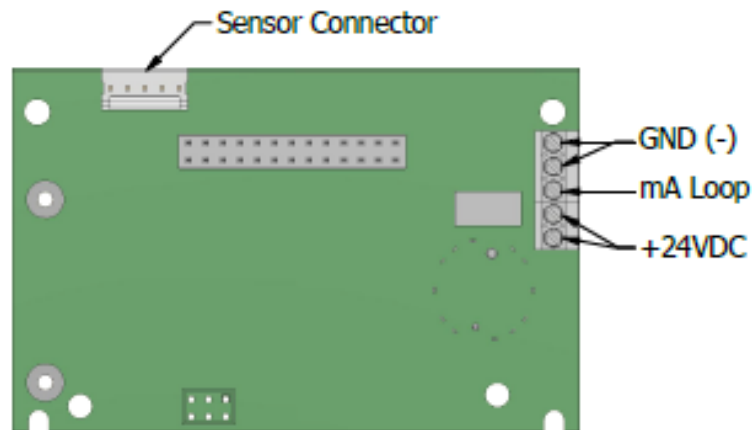

Caution: DO NOT connect to a powered current loop receiver. The Air Check Oxygen monitor supplies the current loop power.

DO NOT disconnect or reconnect the sensor when monitor is powered on.

3.3.2 Relay Board Connections

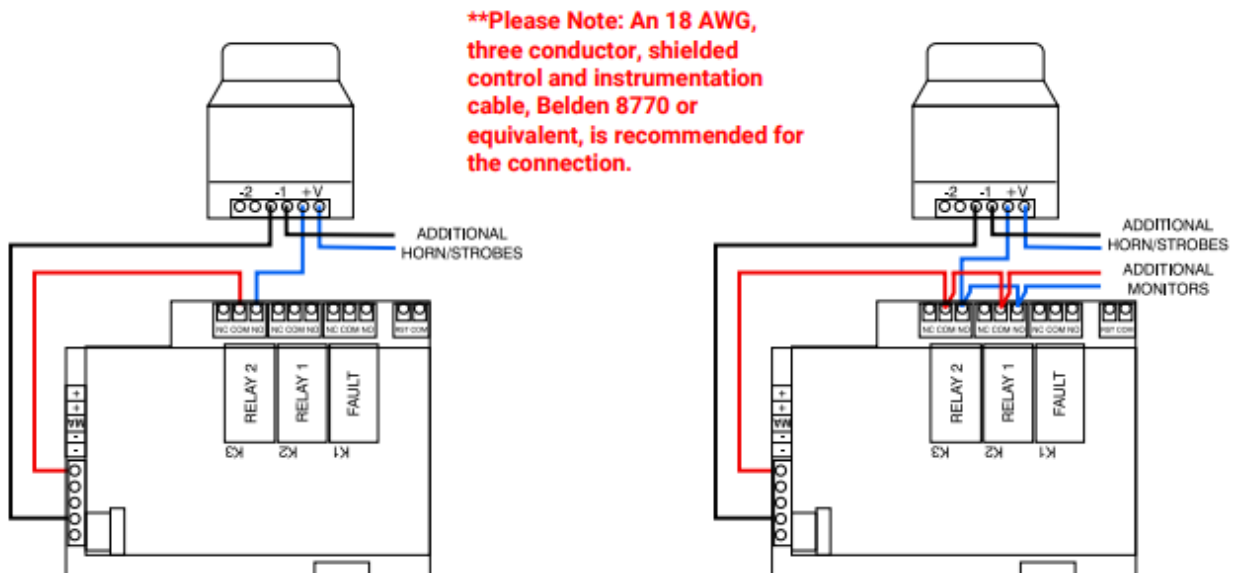

4: Normal Operation

The Air Check O₂ monitor is a single point monitor designed for the continuous detection and measurement of ambient oxygen concentration levels.

4.1 Signal Outputs

The Air Check O₂ monitor consistently outputs an analog signal ranging from 4-20 mA, corresponding directly to the measured oxygen concentration. A 4-mA output signifies 0% O₂, while a 20-mA output denotes the maximum value, representing the full operational range of the monitor. If a system fault occurs, a specific factory-designated code will appear on the local digital display, which will help identify the exact issue with the system.

CAUTION: DO NOT connect to a powered current loop receiver. The Air Check Oxygen monitor supplies the current loop power.

4.2 Instrument Faults

The Air Check O₂ monitor incorporates several self-checking features to ensure reliable operation. If a fault condition is detected, the analog signal output is altered. Common error codes are displayed in the following table.

Condition	Error Code
EEPROM Fault	8
Supply Voltage Out of Range†	16
Flow Sensor Fault	32
Oxygen Cell Voltage Fault	64
Oxygen Cell Complete Failure	128
Oxygen System Warmup‡	—

When the monitor is in a Fault state, the analog output will be locked to 2 mA.

† When using a non-PureAire power supply, please ensure that the voltage is regulated to 24±0.5VDC. If the voltage is outside the acceptable range, the “Supply Voltage Out of Range” fault will be activated and will disable the monitor.

‡ The Oxygen system requires a 4-minute warmup period before entering normal operation. During this period the analog output will be locked at 2mA, and the fault relay will be activated until the warmup is completed.

*If a Fault condition clears itself, (Yellow LED is no longer illuminated) the Fault message will continue to scroll until manually cleared. To clear the fault message, push the joystick **down** ↓.*

4.3 Routine Maintenance Schedule

Continuous gas detection systems, crucial for identifying hazardous gas leaks in various environments, require routine maintenance to ensure proper functioning. The frequency of this maintenance largely hinges on the specific environmental conditions. However, as a general

guideline, it is recommended to conduct visual inspections **every 1 year** to verify the physical integrity of the system. Similarly, testing the system with nitrogen every 12 months is advisable to confirm the sensor's responsiveness. Please remember that your organization's maintenance policies, along with the unique conditions of your application, may necessitate adjustments to this recommended maintenance schedule.

During normal operation, the unit should be outputting a 17.4 mA signal when the oxygen level is at 20.9%. The LCD digital display should also indicate 20.9% O₂ when the oxygen is at ambient levels.

4.4 Loss of Power Indication

In the event the Air Check O₂ monitor loses 24VDC power, the analog output signal will drop to 0mA, and the LCD display will be blank.

4.5 Alarm Reset

The Air Check O₂ monitor comes equipped with alarm relays. When the monitor's alarms are triggered, the built-in alarm relays, panel-mounted LEDs, and audio horn will activate simultaneously. Depending on the relay settings, the alarm systems will either automatically reset (non-latching settings) or require manual reset (latching settings).

To manually reset the alarms, you can use the joystick or the remote reset function:

1. **Joystick:** To use the joystick for reset, you first need to enter the designated password to access the reset function. Once the password is accepted, you can push in (enter) the joystick to reset the alarms.
2. **Remote Reset:** The alarm relay board includes a two-pin connector for wiring to a remote switch. When a switch is connected, this remote reset function allows you to reset the alarms without using the joystick or needing to enter a password.

Please note: Before you can reset the horn using either the remote reset switch or the joystick, the oxygen levels must return to above the alarm thresholds.

5: Monitor Programming

Only qualified personnel should perform programming, maintenance, and sensor verification.

The Air Check O₂ Deficiency Monitor comes with customizable settings, allowing users to modify alarm settings, 4 and 20mA output, and minor sensor adjustments. These settings are organized within menus that can be navigated using the joystick. Access to these menus is secured with a factory-set password.

Please note: Even while adjusting settings within these menus, the Air Check O₂ Deficiency Monitor will keep monitoring oxygen levels. **The alarm, fault relays, and mA output remain active and online during any changes made within the menus.**

5.1 Joystick Operation

The Air Check Monitor uses a 4-position joystick with a center pushbutton for selecting menus and changing values. The joystick is programmed to standard protocol as follows:

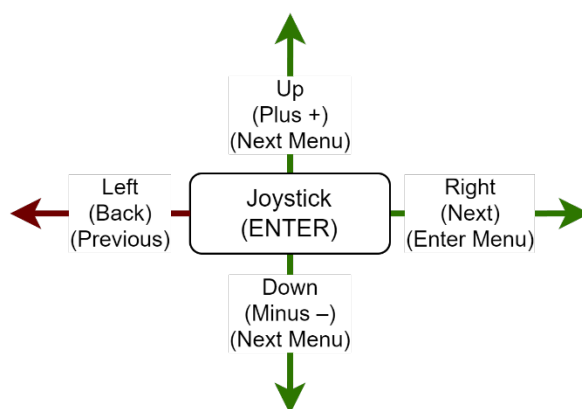

- Up – Increases the value
- Down – Decreases the value
- Right – Next level of menu hierarchy
- Previous – Returns to previous level of menu hierarchy
- Enter – Enters information into the microprocessor

NOTE: The joystick has a built-in delay to prevent accidental tampering of the menus.

5.2 Hall Board/Magnetic Wand Operation

The new Explosion Proof (EXR) Monitors utilize hall effect sensors and a magnetic wand interface. This design ensures operator safety by eliminating exposure to potentially dangerous conditions. Approximate input locations for menu selections are clearly indicated with red circles overlaid on the monitor's interface diagram below. An LED indicator will illuminate upon successful activation of each control, providing clear visual confirmation.

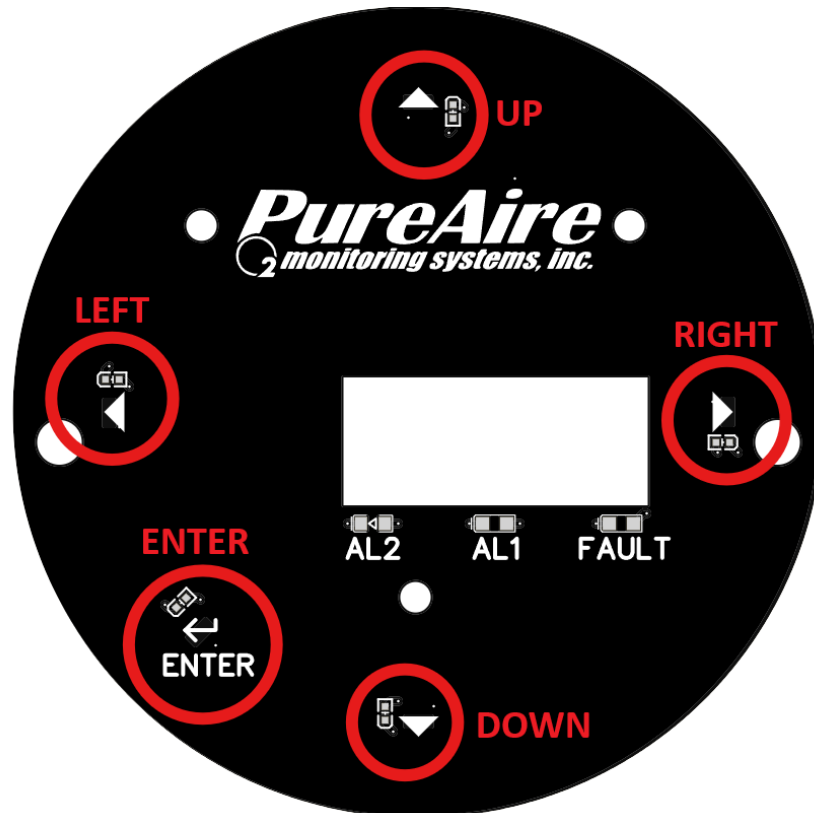

The controls adhere to a standardized protocol:

- Up – Increases the value
- Down – Decreases the value
- Right – Next level of menu hierarchy
- Left – Returns to previous level of menu hierarchy
- Enter – Enters information into the microprocessor

NOTE: The entry interface has a built-in delay to prevent accidental tampering of the menus.

5.3 Overall Program Flowchart

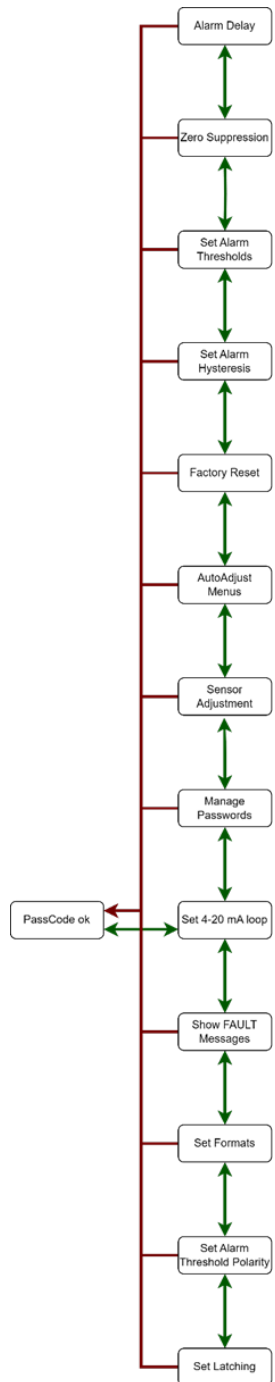

5.3.1 Top Level Menu Navigation

After entering the correct password, the monitor will display “PassCode ok”. To exit the password menu and return to the default screen, move the joystick to the left.

To access the internal settings, move the joystick to the right to enter the ‘Set 4-20 mA loop’ top-level menu state.

Once in this menu state, you can navigate through other top-level internal menus by moving the joystick up or down.

To return to the “PassCode ok” screen from any top-level internal menu, move the joystick to the left. From sub-menus, toggle left until the “PassCode ok” menu state is reached.

5.4 Entering Password

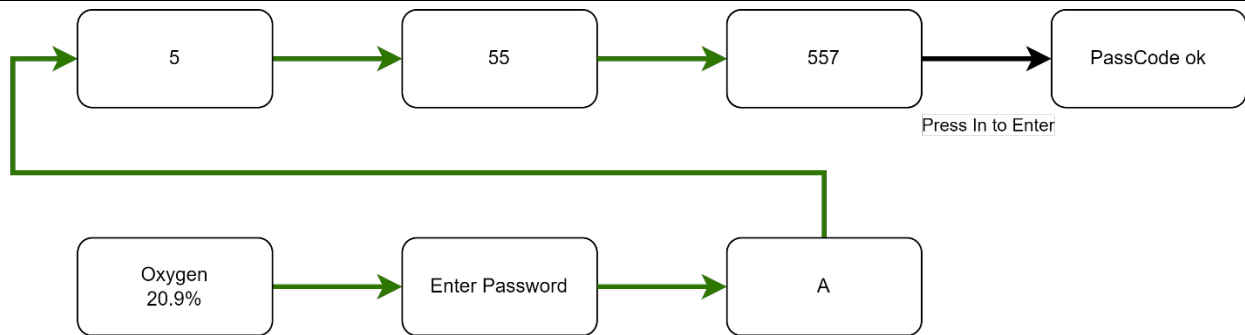

5.5 Changing the User Password

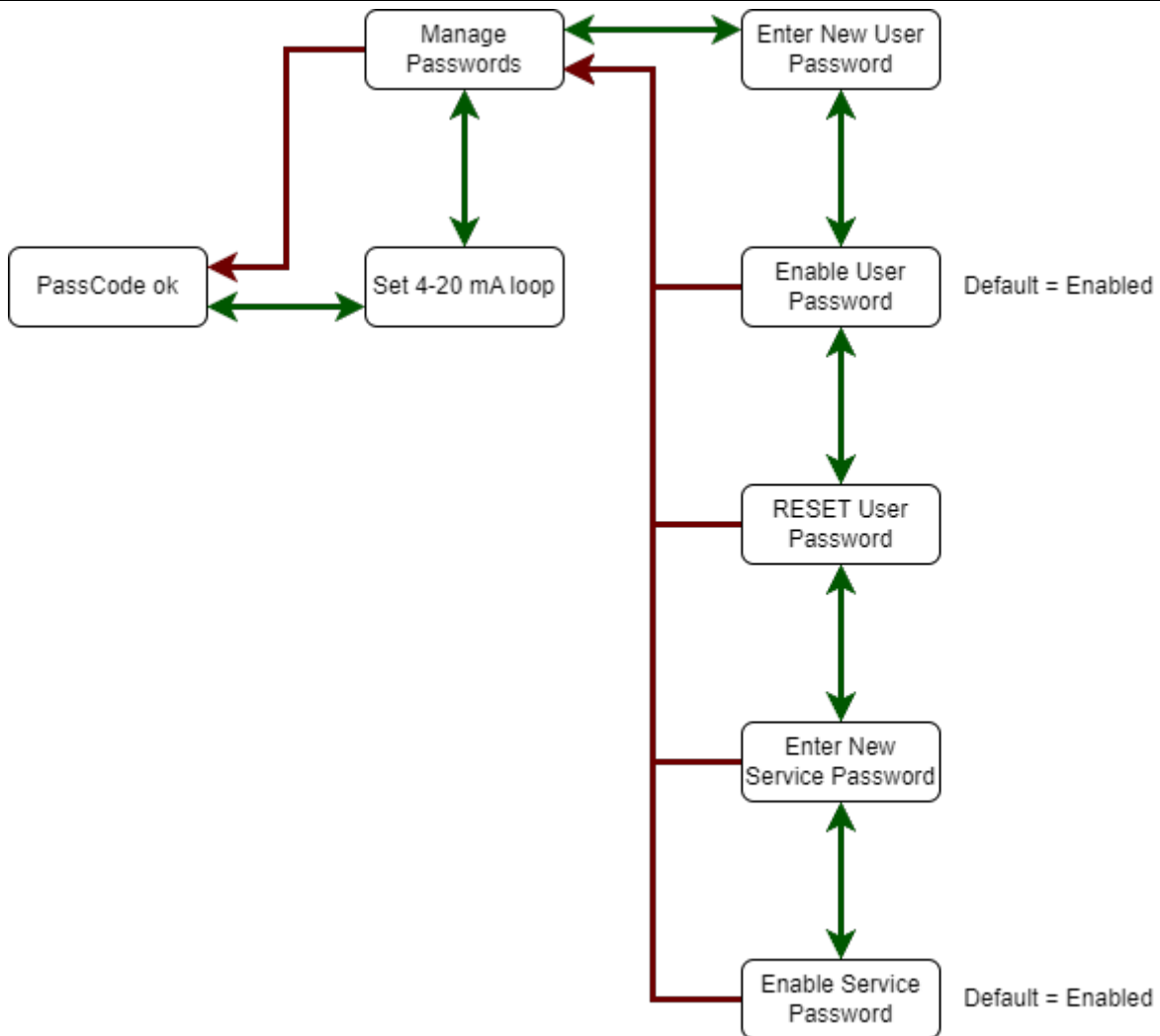

5.6 Setting 4-20mA Loop

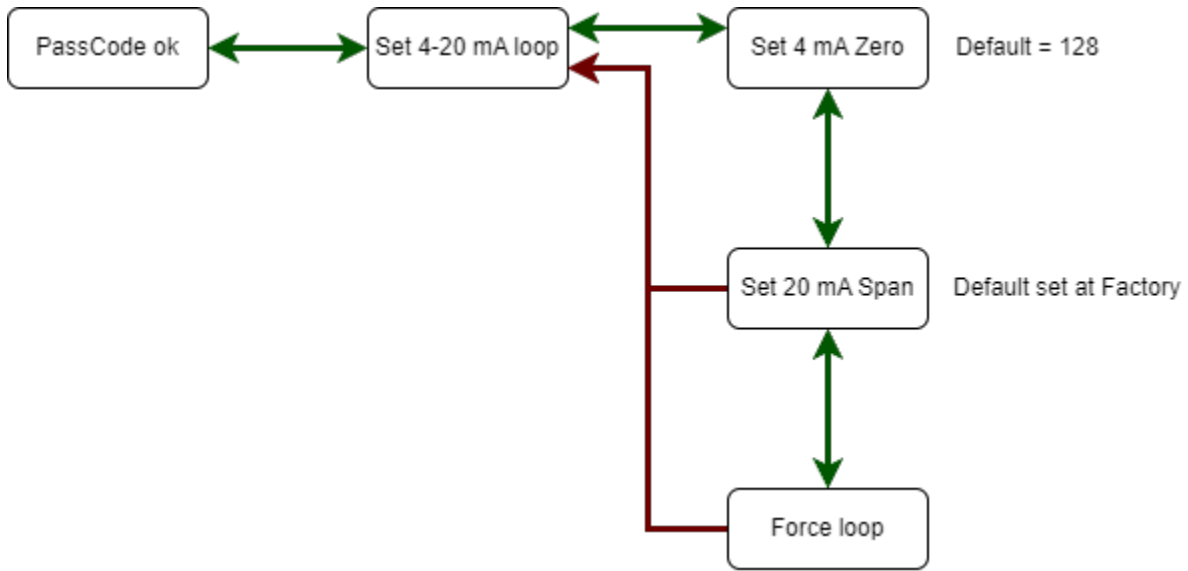

5.7 Setting Relay Formats

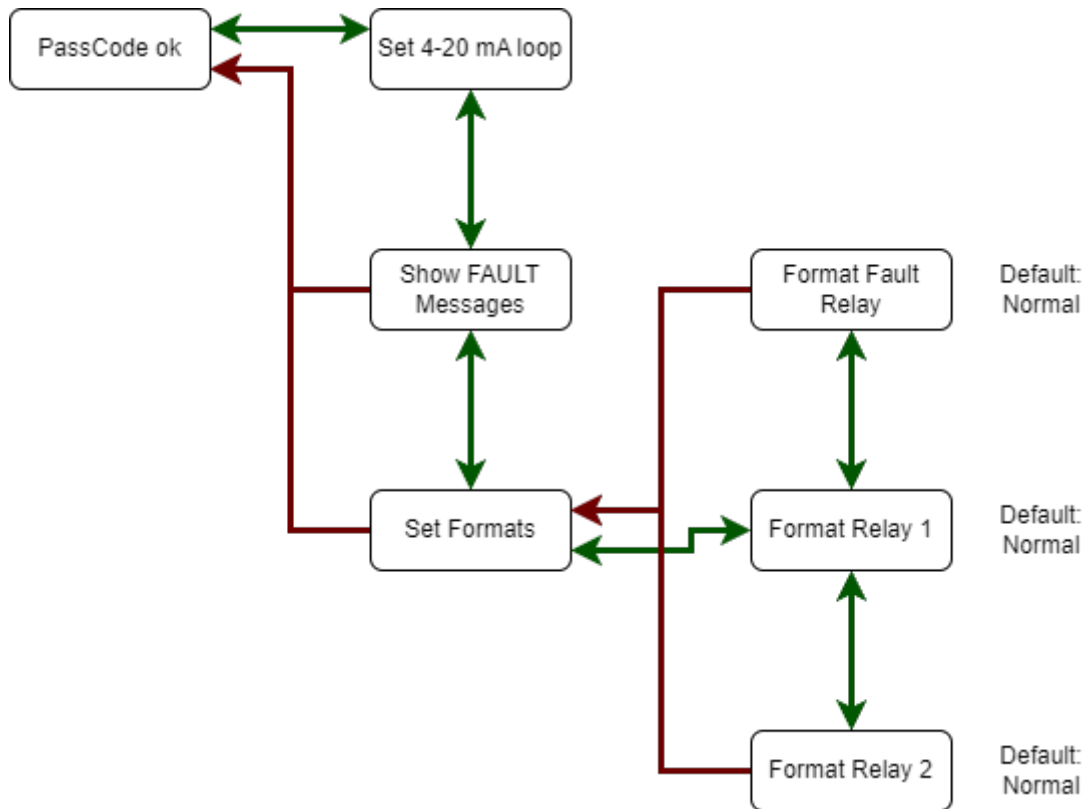

5.8 Setting Alarm Polarity

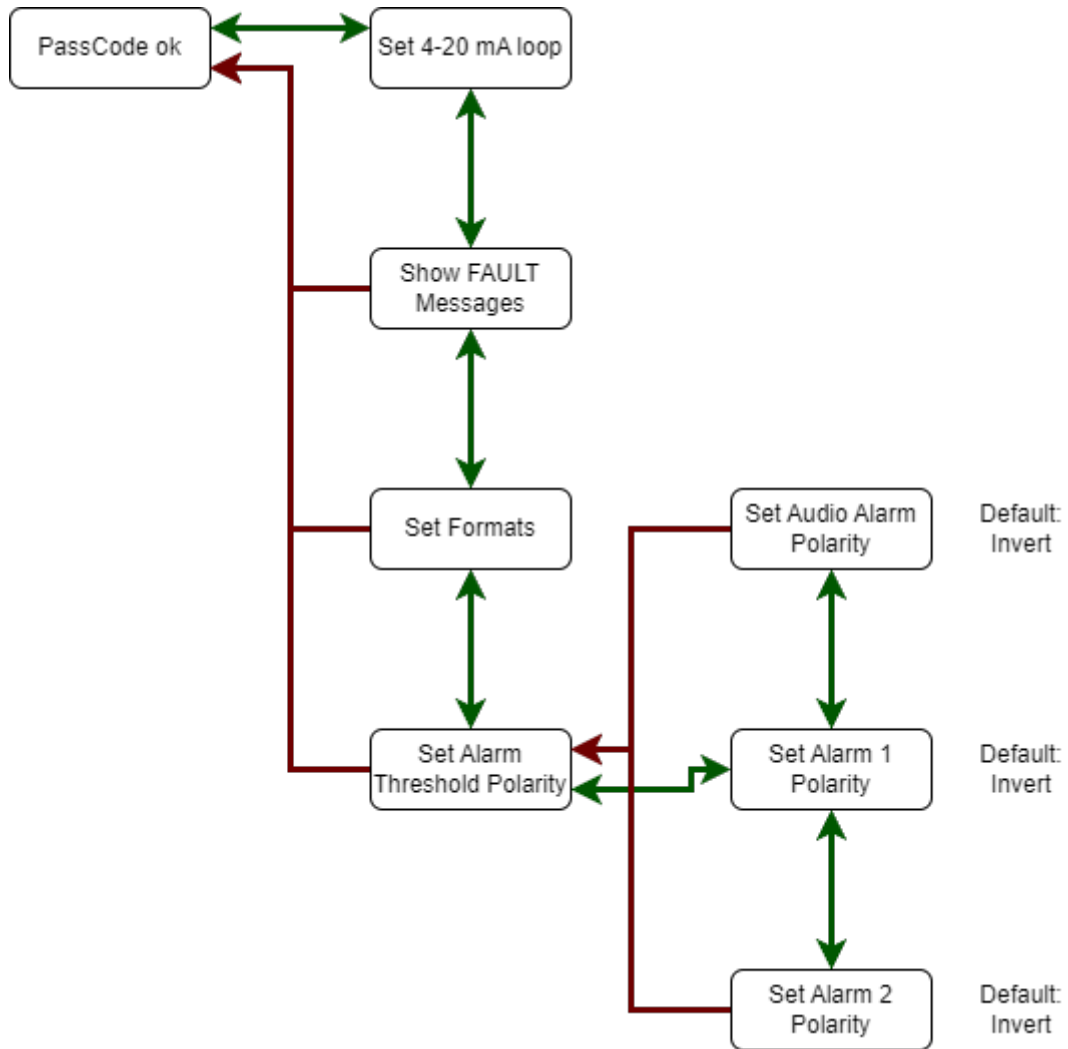

5.9 Setting Alarm Latching

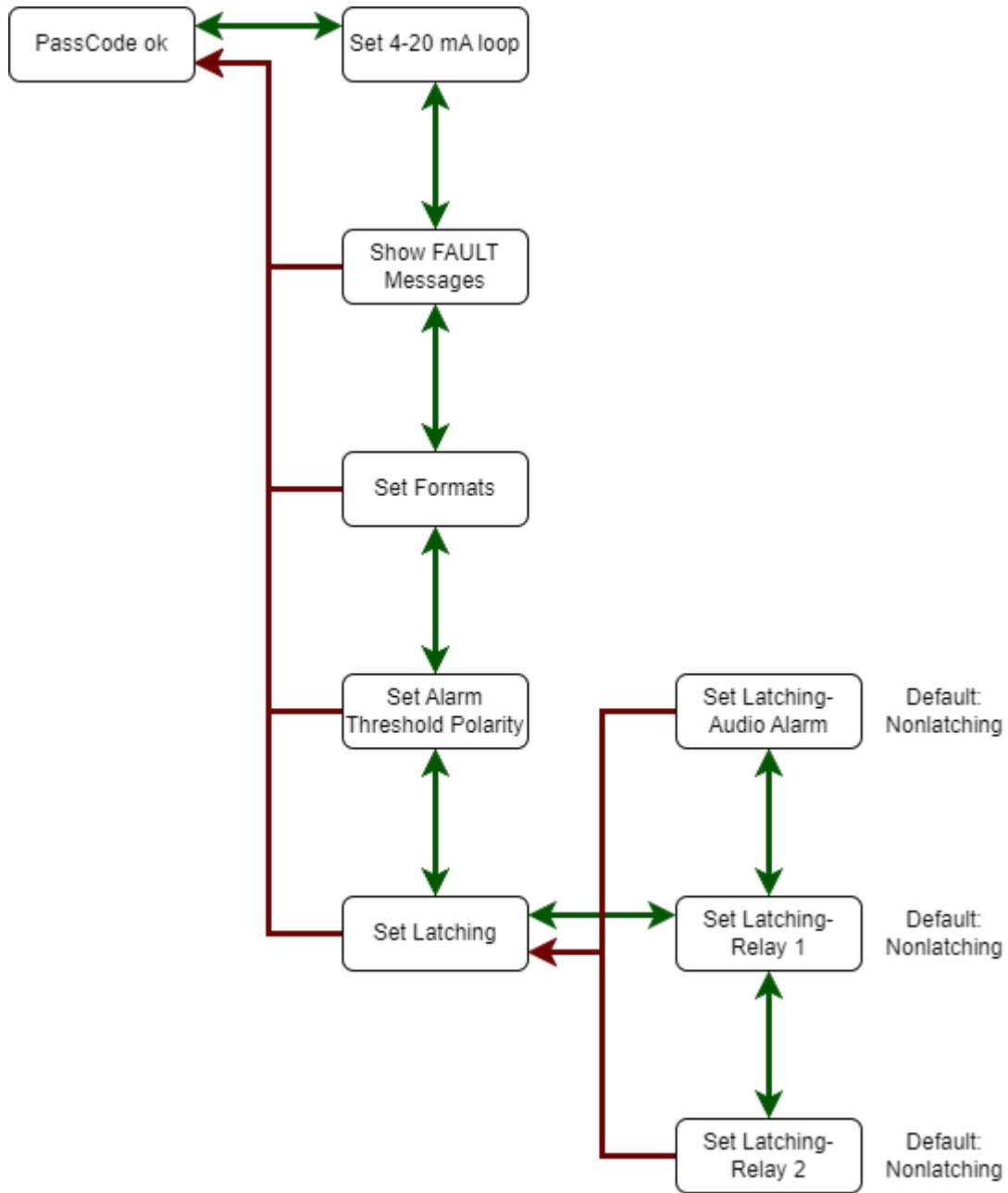

5.10 Sensor Adjustment Menus

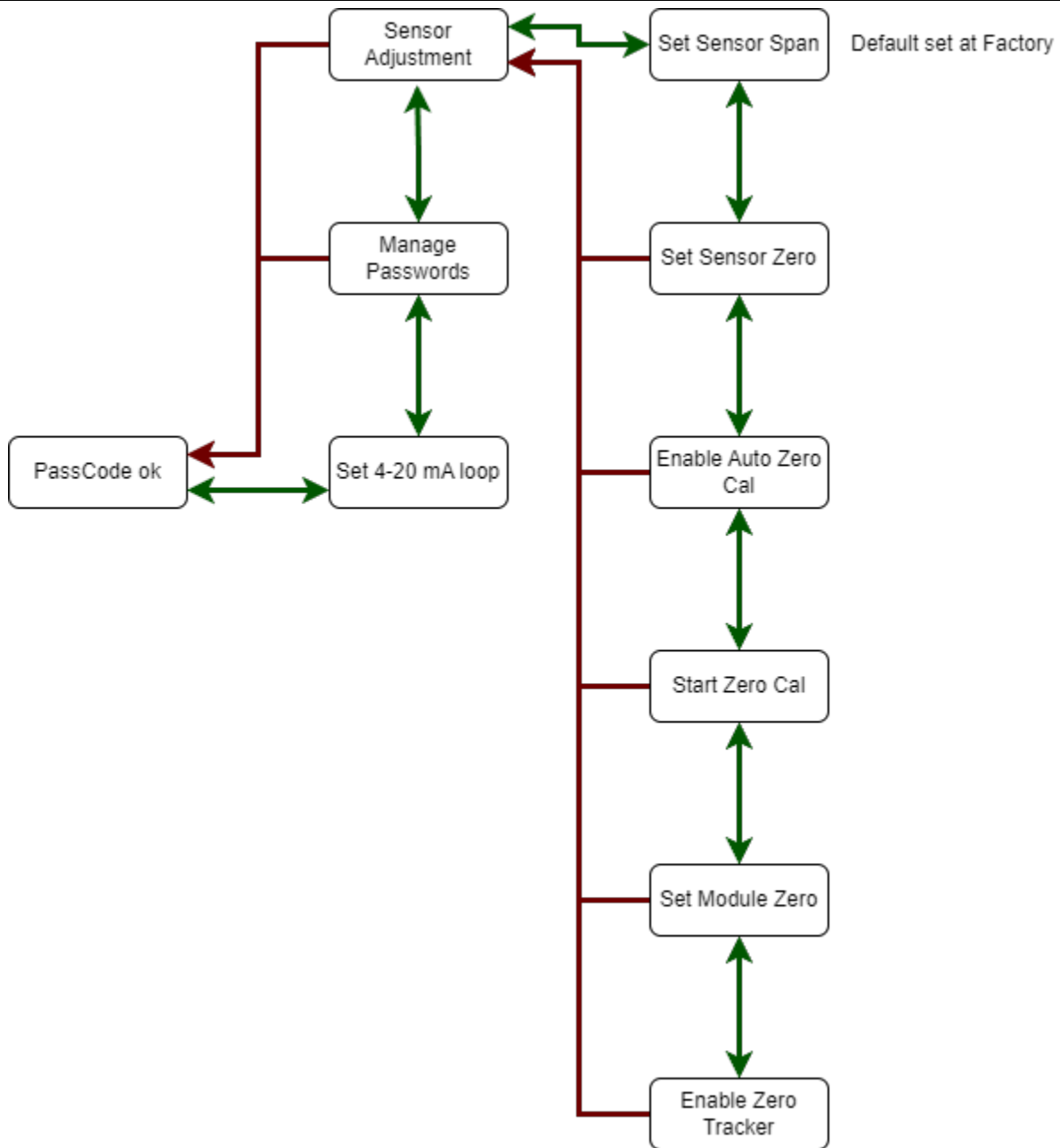

Please refer to Section 6.5 for Manual Monitor Span Adjustment.

5.11 AutoSpan Menus

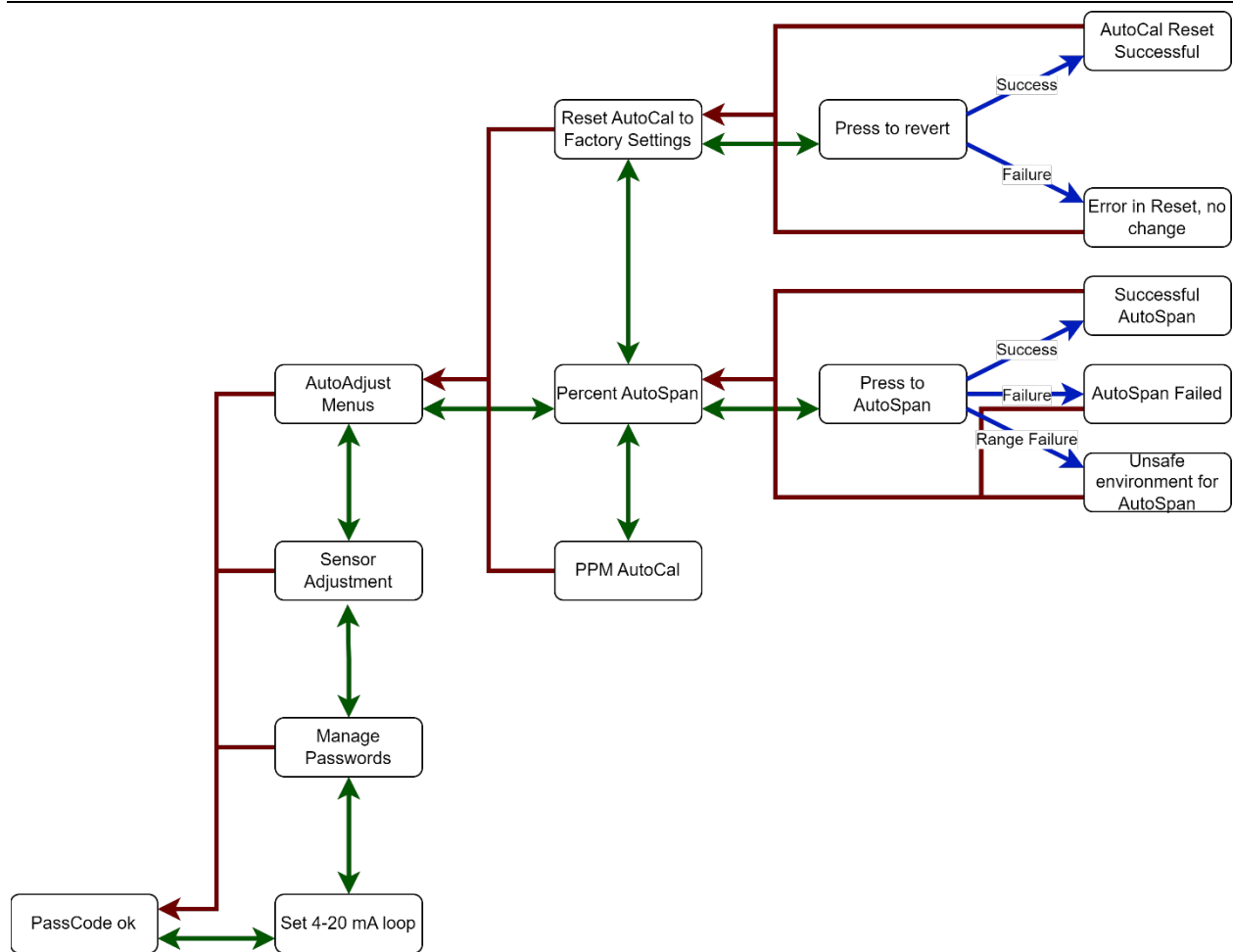

Please refer to Section 6.4 For AutoAdjust Functions.

5.12 Factory Reset Menu

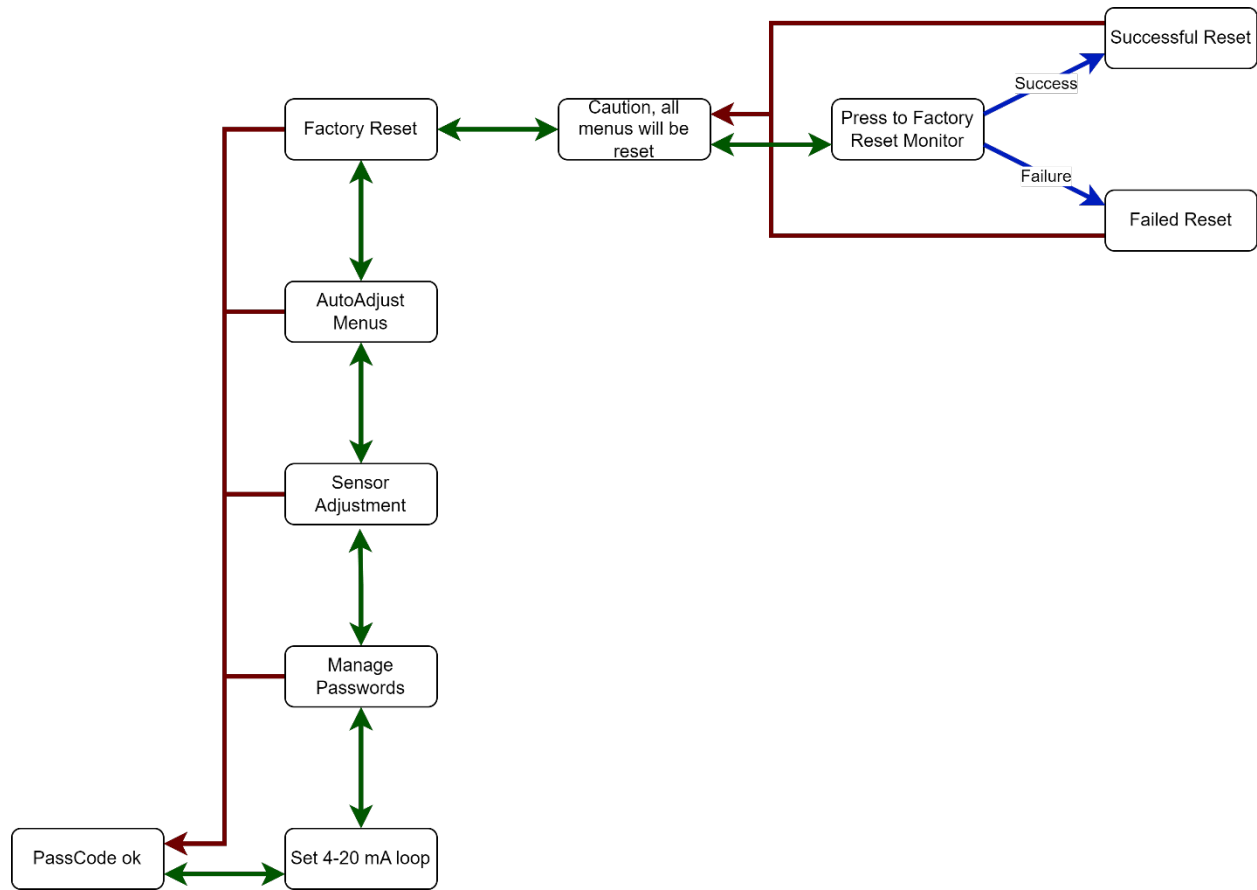

Please refer to Section 2.6 for Default Factory Settings and resettable settings.

5.13 Setting Alarm Hysteresis

5.13.1 Hysteresis

Hysteresis refers to a system's dependency not just on its current input, but also on its past history of inputs. It's a fundamental concept employed in various scientific and engineering fields, often used to stabilize systems and prevent them from rapid fluctuations in response to minor changes in input, a phenomenon commonly referred to as "chatter". The application of hysteresis, thus, can provide more consistent and reliable system operation.

In control systems or sensors, hysteresis introduces a buffer zone of sorts, within which the system maintains its current state even as the input varies. This has the practical effect of preventing a system from overreacting to small or brief changes in the inputs.

Consider an example in an oxygen monitoring and control system where we want a valve to close when the oxygen level drops to 14.9% and reopen when it reaches 15.5%. The implementation of hysteresis allows us to set the alarm threshold at 15.2%, with a hysteresis value of 0.3%. This means that when the oxygen level falls to 15.2%, the system will trigger the alarm, and the valve will close. However, the valve will not reopen immediately when the oxygen level rises back to 15.2%. Instead, it will wait until the oxygen level reaches the upper hysteresis limit of 15.5% ($15.2\% + 0.3\%$). This strategy prevents the valve from frequently opening and closing due to small fluctuations around the 15.2% level, ensuring more stable operation.

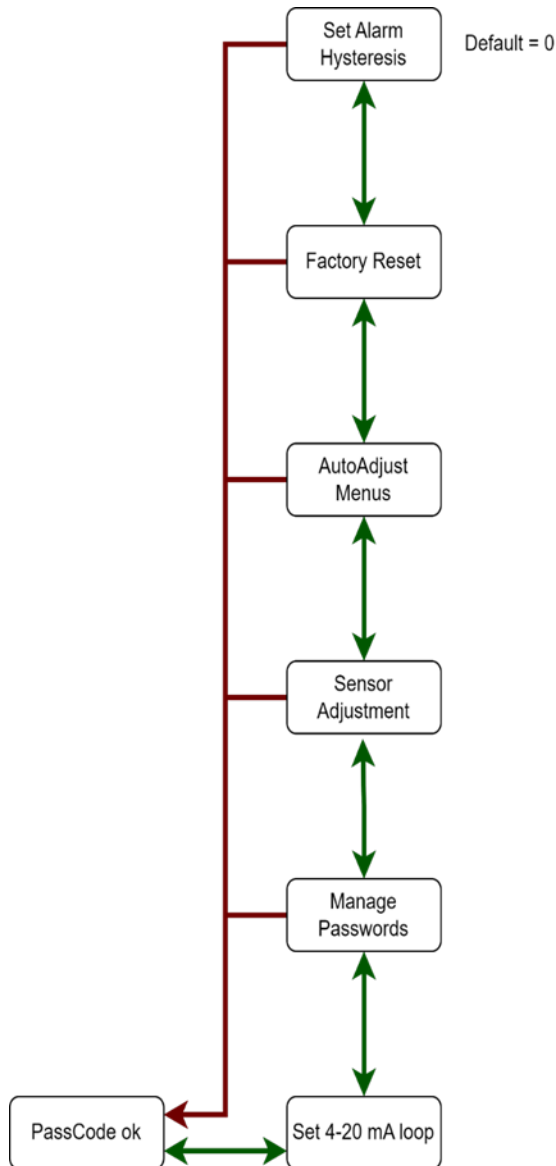

5.14 Setting Alarm Thresholds

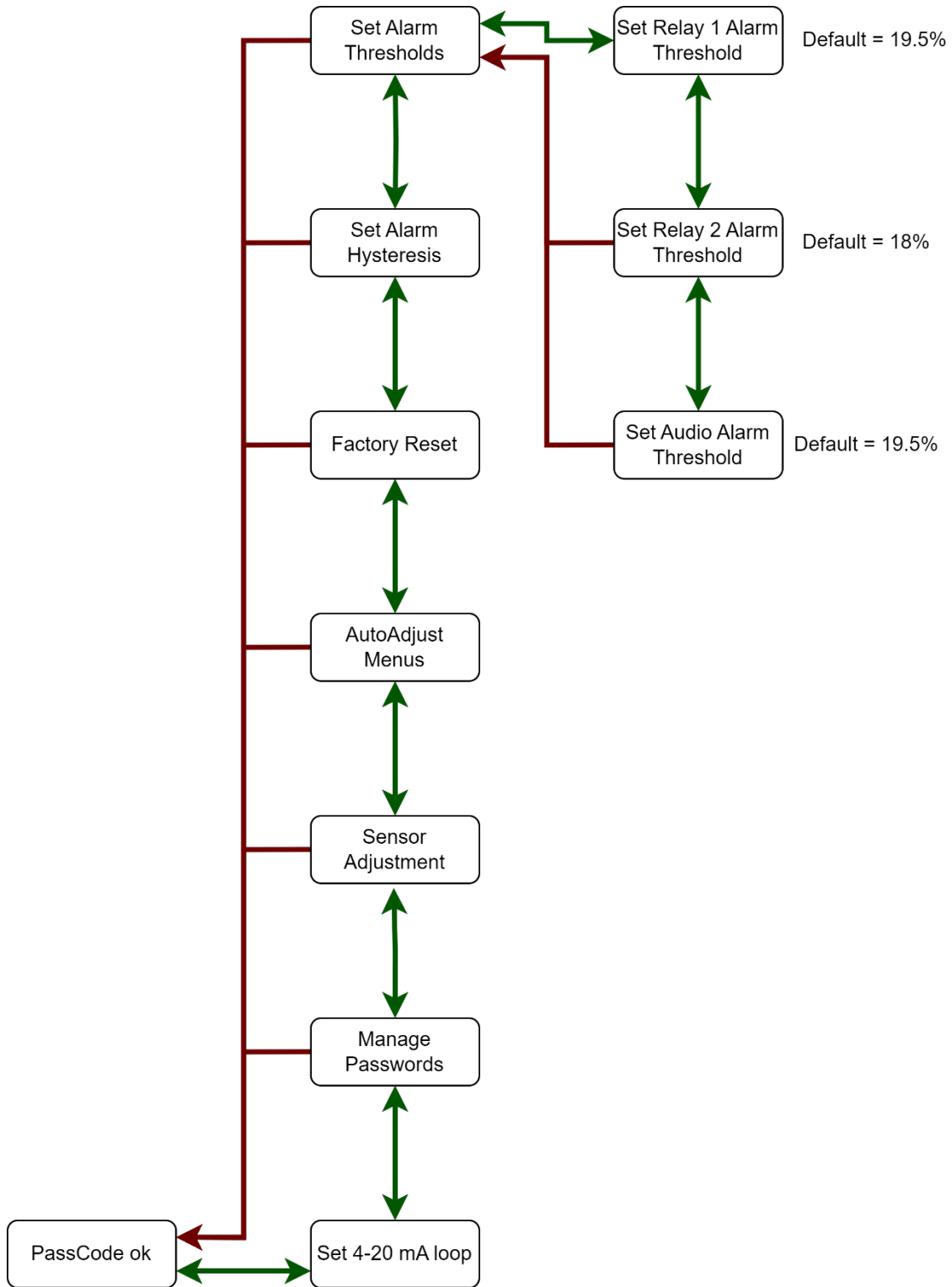

5.15 Setting Alarm Delay

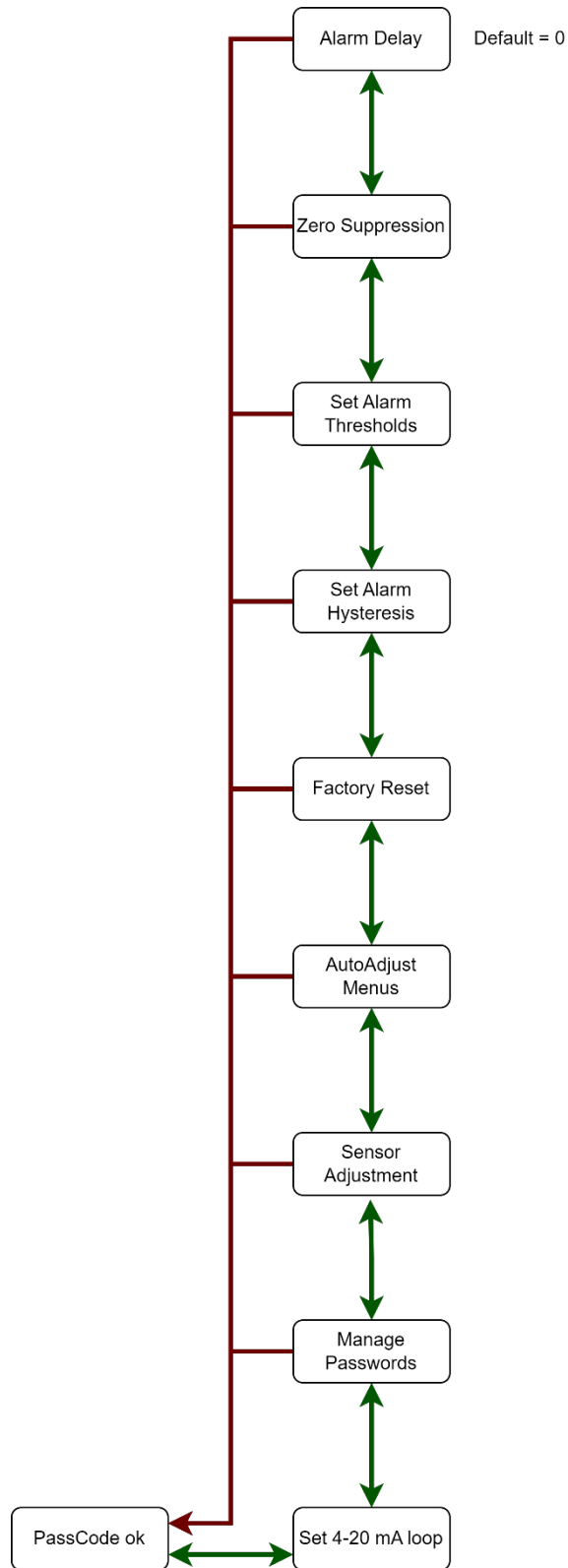

6: Maintenance & Sensor Verification

Only qualified personnel should perform maintenance and sensor verification.

6.1 Setting Alarm Delay

Earth's atmosphere naturally contains oxygen at a stable concentration of 20.9%. Therefore, under normal conditions, you can visually verify the Air Check O₂ monitor's readings against this natural standard. The monitor requires occasional testing with nitrogen to validate the sensor's response to low oxygen levels. Furthermore, an annual fine-tuning might be necessary to ensure the sensor's span accurately corresponds to the standard 20.9% oxygen concentration.

6.1.1 Sensor Verification Gas

For testing the Air Check O₂ monitor, PureAire recommends the use of nitrogen balanced mixtures. For factory calibration and verification, the mixtures used are:

- 99.9% (UHP) N₂
- 8% O₂ in N₂ balance

Gas can be purchased from your local gas supplier or can be recommended by PureAire as required.

6.1.2 Sensor Verification Equipment

For the verification process of the sensor, you'll require a few specific pieces of equipment:

1. Gas Tank: At our facility, we typically use a 103 L lab bottle with an on-demand regulator.
2. Regulator: A regulator compatible with your chosen gas tank is necessary. In the case of a 103L lab bottle, we recommend a C10, on-demand regulator.
3. Tubing: Appropriate tubing to connect the regulator to the sensor is also required.

Remember to use an on-demand regulator. This guarantees a consistent and controlled supply of gas during the verification process while verifying the sample draw functionality of the unit.

Subjecting the Air Check monitor to different concentrations or mixtures of oxygen span gas is acceptable. Please take care to not expose the sensor to any harmful gases.

NOTE: If the instrument is connected to a controller, set the controller on standby mode to avoid accidental alarms.

6.2 Sensor Functionality Verification Procedure

CAUTION: Always adhere to all safety protocols while producing and handling nitrogen or any other oxygen-depleting gases.

Testing the sensor and monitor's response to an oxygen-deficient environment provides a quick check on their functionality. One efficient method is to apply Ultra-High Purity (UHP) nitrogen (99% N₂). The monitor reading should drop to less than 1% O₂ within a minute. Upon removal

of the gas, the unit should recover to the ambient oxygen level of 20.9% within the same timeframe.

Alternatively, you can test with a known oxygen concentration and verify that the monitor reaches a reading within $\pm 0.2\%$ of this value. For example, using a bottle of 8% oxygen in nitrogen balance, certified by the National Institute of Standards and Technology (NIST), should result in a monitor reading of 8.0% O₂.

During this verification process, check that optional features like the alarm relays and audio alarms are triggered during the alarm state and deactivate appropriately after the test.

If the sensor reading deviates more than 0.2% from the expected value, you may need to recalibrate the monitor. If the sensor doesn't recover, or has difficulty reaching low percentage readings, please reach out to PureAire for more comprehensive servicing.

6.3 Ambient Oxygen Level Verification

The Air Check O₂ monitor should typically display a reading of 20.9% in a clean, non-oxygen-deficient environment, mirroring the ambient oxygen concentration. However, over time and with sensor aging, this reading may marginally decrease. Hence, we recommend an **annual** verification and adjustment of the sensor's span to reflect the ambient oxygen concentration of 20.9%.

For this process, it's crucial to position the Air Check O₂ monitor in an environment devoid of oxygen deficiency or contamination. This ensures an accurate reflection of the ambient oxygen concentration, promoting the device's precision and longevity. Using this procedure, you can span adjust the O₂ monitor to accurately display the oxygen concentration as 20.9% under standard, non-oxygen deficient conditions.

See sections 6.4 & 6.5 for instructions on span adjustment.

NOTE: It is recommended to warm up the Air Check Oxygen monitor for at least two hours before making any adjustments to the sensor.

6.4 AutoAdjust Functions

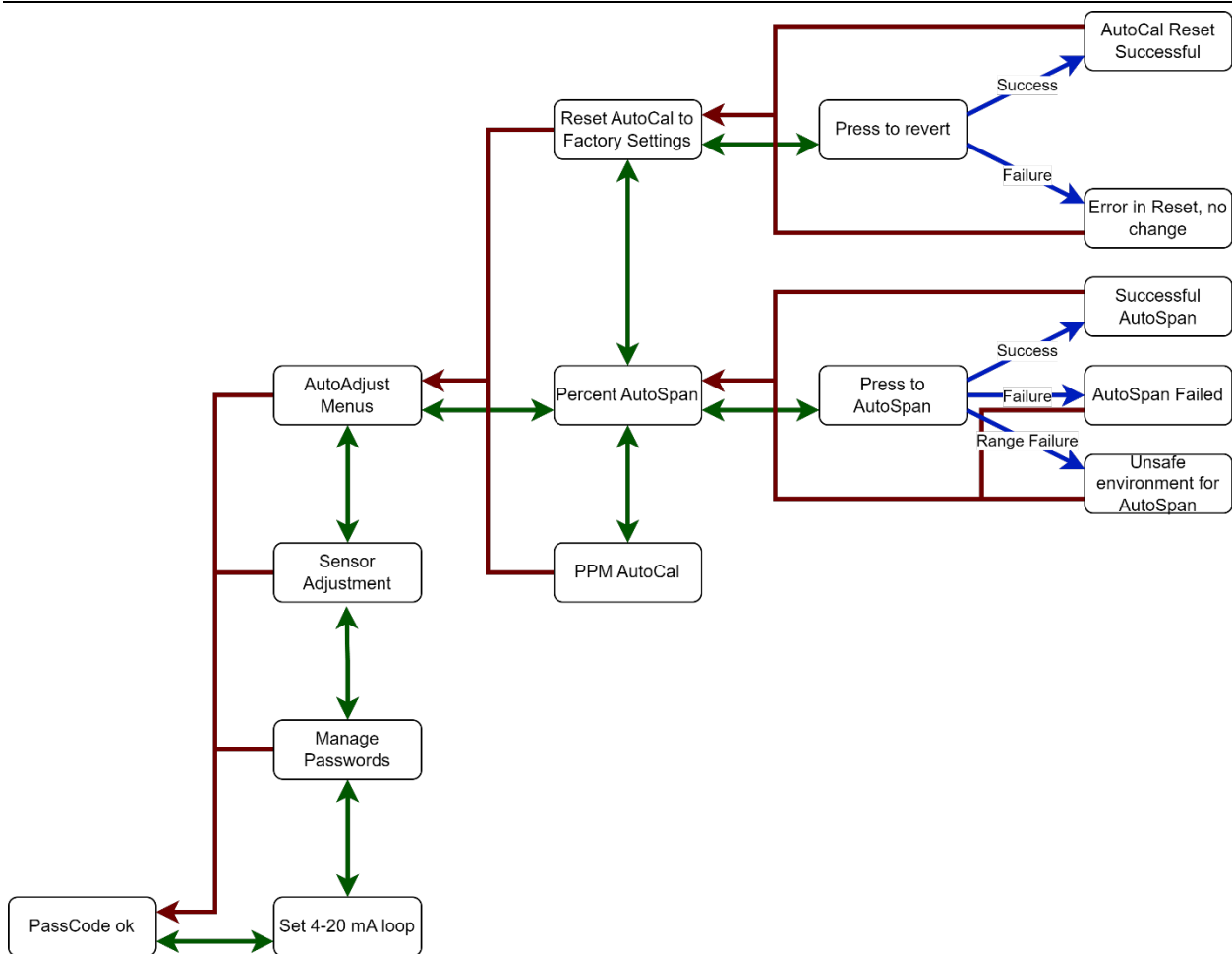

6.4.1 Monitor AutoSpan

The V5.0 update introduced the AutoSpan feature for the monitor, which can be accessed using the user password (default = 557). Once “Password ok” is displayed, navigate to the AutoAdjust Menu using the joystick. Within the AutoSpan menu, toggle right and then press in to start AutoSpan when prompted to ‘Press to AutoSpan’.

This innovative feature adjusts the internal span of the monitor to match the ambient oxygen level, nominally at 20.9%. Please note that PureAire’s specifications state that the monitor’s accuracy is within $\pm 0.2\%$. If the monitor’s reading is already within 20.7-21.1%, the AutoSpan function will be unavailable and any attempts to AutoSpan will not modify the internal settings.

Moreover, if the monitor’s reading is < 19.5 or $> 22.5\%$, an “Unsafe environment for AutoSpan” alert will appear upon attempted AutoSpan, and no changes will be made. This is a safety feature designed to ensure accurate readings.

Even though AutoSpan is a helpful new addition, standard manual span adjustment is still available as per your needs. For manual adjustment, please see Section 6.5.

6.4.2 Reset AutoCal to Factory Settings

The V5.0 update also included a new menu option called “Reset AutoCal to Factory Settings”. This feature allows you to reset only the sensor’s span to its original factory settings, without affecting other parameters such as alarm thresholds or relay formats that you may have customized.

To use this option, navigate to the “Reset AutoCal to Factory Settings” menu, and when prompted, press in to initiate the reset. This will revert the sensor’s span to its factory setting while keeping your personalized configurations intact.

6.5 Manual Monitor Span Adjustment

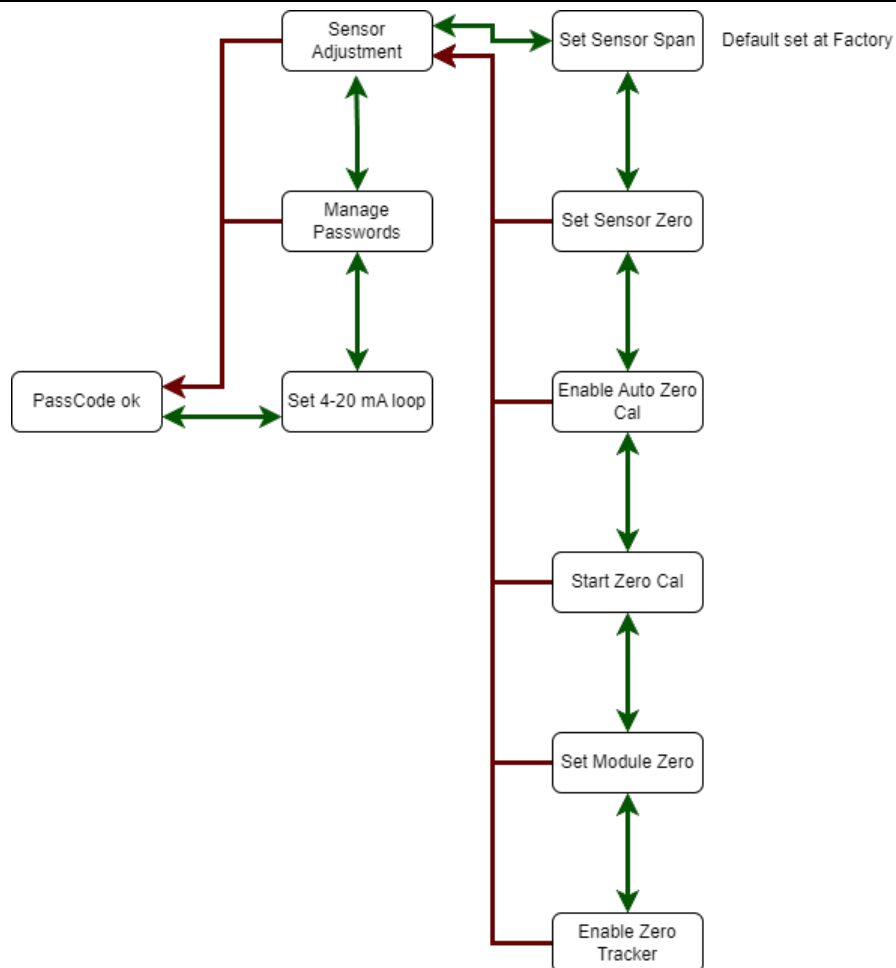

Navigate to the “Set Sensor Span” menu and toggle right to access the sensor span. The display will indicate a value between 0 and 255 counts. Pushing up or down on the toggle will increase and decrease the count value respectively. To increase the displayed reading on the monitor, decrease the sensor span.

Adjust the span until the digital display reads $20.9 \pm 0.2\%$. Press ENTER on the joystick to accept the value.

NOTE: The monitor can be calibrated to a known concentration of Oxygen, to see the exact span gas concentration the entire Air Check O₂ monitor needs to be completely immersed into the span gas environment.

CAUTION: For best results, the Oxygen monitor should be protected from wind and high airflow when gas calibrating with test gas, as well as tested in an upright position to allow the span gas to fully saturate the sensor cell.