

# PureAire Carbon Dioxide (CO<sub>2</sub>) Monitor

Instruction Manual

**Part Numbers 99174,  
99191**

**CO<sub>2</sub> range 0-50,000ppm**



# *Welcome to PureAire Monitoring Systems*

**I'd like to thank you for investing in our continuous life safety and process control toxic gas monitoring systems.**

**PureAire offers an unbeatable combination of experience and innovation in solving the safety and environmental needs of our customers. We can provide small systems of a few points to a total multi-point turnkey computerized package.**

**PureAire's proprietary sensor cell technology and state-of-the-art electronics are designed to interface with the latest distributive or PLC based control systems. We believe that our experience, innovative products and commitment to service will satisfy your specific monitoring needs now and in the future.**

**Our growth is a result of our total commitment to supporting our customers. We are available 24 hours a day, 7 days a week to help you when you need us. Our 24 hour Emergency phone number is 1-224-443-5445. We can provide field service, preventative maintenance programs and training to your technicians in the operation of our equipment. Our goal is to provide the best after sale service and support in the industry. That is just one way PureAire takes that extra step to ensure your complete satisfaction.**

**Thank you again for investing in PureAire Monitoring Systems for your monitoring needs and I'm proud to welcome you to our family of valued and satisfied customers.**

**Sincerely,**

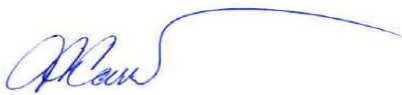

**Albert A. Carrino  
President**

## Please Read Before Installation

The following will damage the Air Check Carbon Dioxide monitor.

1. The CO<sub>2</sub> monitor requires **24 VDC regulated power**.  
**Please Do Not connect** the monitor to any voltage that exceeds 24 Volts DC, or **Any AC Voltage**.
2. Do not power the carbon dioxide sensor unplugged from the main PC board. **Do Not Connect** the CO<sub>2</sub> sensor to the PC board while the monitor is powered. This Will Damage the sensor.
3. The CO<sub>2</sub> cell range is matched to the electronics. **Never exchange** the electronics with a CO<sub>2</sub> sensor from a different monitor.
4. When calibrating or challenging the CO<sub>2</sub> monitor,
  - a. Do not expose the monitor to flow rates that exceed ½ liter per minute, (500 cc per minute) flow.
  - b. Expose the monitor to span gas blends that consist of Oxygen, Nitrogen or Carbon Dioxide only. **Do Not expose the monitor to any combustible gas**, i.e., Methane, Hydrogen, etc.
5. Do not expose the CO<sub>2</sub> monitor to silicone compounds. They can cause a loss of sensitivity.
6. Do not expose the monitor to high flow air or install it directly in front of fans.
7. When using the CO<sub>2</sub> monitor, do not expose the sensor directly to a water stream. In areas requiring wash downs, cover and protect the monitor and power supply. Contact PureAire for details on a waterproof enclosure.
8. Please refer to section 6.3 of this manual regarding the CO<sub>2</sub> sensor. **YOU MUST** choose a calibration method before use.

# Table of Contents

1: Introduction .....	4
1.1 Key Features .....	4
1.2 Component identification .....	5
2: Specifications.....	9
2.1 Performance Specifications .....	9
2.2 Gas Detection System.....	9
2.3 Signal Outputs .....	9
2.4 Electrical Requirements.....	9
2.5 Physical Characteristics .....	9
2.6 System Default Factory Settings .....	10
3: Installation .....	11
3.1 Site Requirements .....	11
3.2 Mounting.....	11
3.3 Wiring .....	12
3.4 Initial Startup .....	13
4: Normal Operation .....	14
4.1 Signal Outputs .....	14
4.2 Instrument Faults .....	14
4.3 Routine Maintenance Schedule .....	15
4.4 Loss of Power Indicator.....	15
4.5 Alarm Reset .....	15
5: CO <sub>2</sub> Monitor Programming .....	16
5.1 Joystick Operation .....	16
5.2 Program Flowchart .....	17
5.3 Entering the Password .....	21
5.4 Changing the User Password .....	22
5.5 Entering the Menus.....	25
5.5.1 Set Formats .....	26
5.5.2 Set Alarm Threshold Polarity .....	29
5.5.3 Set Latching.....	30
5.5.4 Resetting a Latching Alarm .....	32
5.5.5 Set Alarm Delay .....	32
5.5.6 Set Zero Suppression .....	34
5.5.7 Set Alarm Thresholds .....	34
5.5.8 Set Alarm Hysteresis .....	36
5.5.9 Auto Calibrate.....	37
5.5.10 Main Operation Mode.....	39
6: Maintenance & Cell Verification .....	40
6.1 Sensor Calibration, CO <sub>2</sub> .....	40
6.1.2 Adjusting the CO <sub>2</sub> sensor manually.....	40
7: Appendix .....	43

# 1: Introduction

---

The **CO<sub>2</sub>** Monitor is a compact gas monitoring system that is ideal for the continuous monitoring of inert gas storage areas, confined spaces, and other locations where carbon dioxide levels may pose a hazard to personnel. The patented NDIR CO<sub>2</sub> cell provides stable readings even in areas where temperature and humidity levels are changing. The PureAire **CO<sub>2</sub>** Monitor is suitable for either indoor or outdoor use. Factory calibrated against a NIST traceable reference standard and Ce approved.

The heart of the monitoring system is an NDIR self-calibrating carbon dioxide sensor. The CO<sub>2</sub> cell responds to high carbon dioxide conditions within seconds and provides accurate measurements over a wide temperature and humidity range. The NDIR CO<sub>2</sub> sensor cell will operate continuously for many years and requires an absolute minimum of maintenance. There are no zero or span calibration pots to adjust and its built-in auto calibration can save time and money in annual maintenance.

Ideal for continuously monitoring carbon dioxide levels in confined spaces or areas where inert gases are used, the **CO<sub>2</sub>** Monitor does not drift or lose sensitivity when the weather or temperature changes. The electronics are housed in a Nema 3 housing.

Each system consists of a long life NDIR sensor cell and three-wire transmitter. The **CO<sub>2</sub>** monitor may be used as a stand-alone gas detector, linked to optional PureAire single and multipoint controllers, or connected to your own centralized control and surveillance system. This manual covers the installation, operation, and maintenance of the **CO<sub>2</sub>** monitor.

## 1.1 Key Features

---

The **CO<sub>2</sub>** monitor incorporates several user-friendly features designed to simplify installation, operation, and maintenance.

### 1.1.1 NDIR CO<sub>2</sub> IR sensor

The system's CO<sub>2</sub> sensor cell is a patented Non Dispersive Infrared, (NDIR) cell designed to detect continuous levels of CO<sub>2</sub>. It is fast responding and has a built-in auto calibration feature that adjusts the sensor to ambient every 180 hours.

### 1.1.2 Smart Electronics

The **CO<sub>2</sub>** monitor incorporates a special electronic circuit that continuously monitors sensor operation. With the addition of the alarm relay option, any cell degradation or complete failure will immediately be detected. This smart circuitry alerts the user to sensor faults and other electrical problems that may interrupt surveillance through the standard mA output signal or through the optional fault relay option.

## 1.2 Component Identification

---

### 1.2.1 Front View Exterior

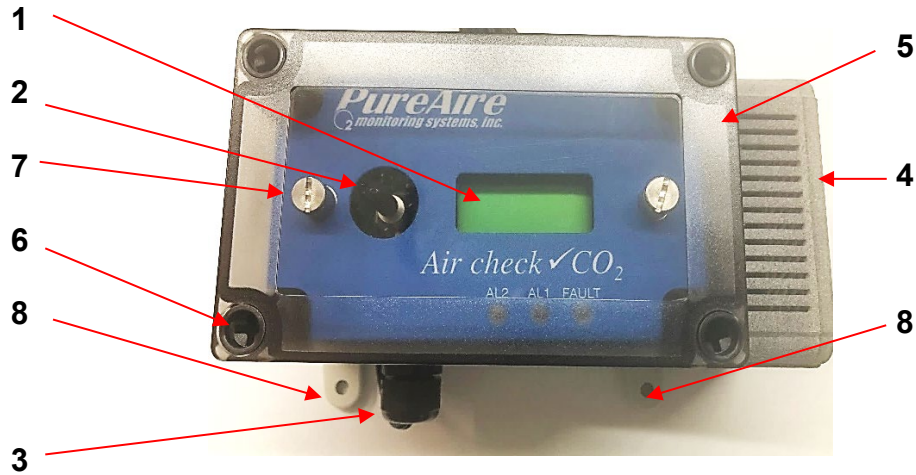

1. **Digital Display** — 3-digit backlit LCD digital display for showing the carbon dioxide levels in parts per million (ppm).
2. **Joystick** — Used for selecting and adjusting the built-in menus.
3. **Cable Port** — This is the opening in the transmitter housing for connecting the 4-20 mA output and 24 VDC power cable.
4. **CO<sub>2</sub> Sensor**— A NDIR sensor housed inside the cell protector.
5. **Transmitter Cover** — A removable cover that protects the interior of the transmitter.
6. **Transmitter Cover Fasteners** — There are 4 captive screws secure the transmitter cover in place.
7. **Electronics Fasteners** — These captive screws secure the electronics to the enclosure
8. **Mounting Feet** — There are 4 feet used to mount the carbon dioxide monitor to a wall or other flat surface.
9. **Alarm Indicators** — 3 multicolored LED indicators for showing:

Alarm level 1, CO <sub>2</sub>	Orange LED
Alarm level 2, CO <sub>2</sub>	Red LED
Fault Alarm	Yellow LED
10. **Audio Horn** — This built-in horn is a 90dB high pitched audio sound will activate when CO<sub>2</sub> levels go above the selected alarm threshold. The audio alarm is non-latching and will automatically turn off when the alarm condition clears.

**NOTE:** *The audio alarm is an immediate alarm. Alarm levels must recover to safe levels before the horn turns off. There is no audible alarm delay function available.*

1.2.2 Front View Exterior



1.2.3 Side View Exterior with Audio Alarm

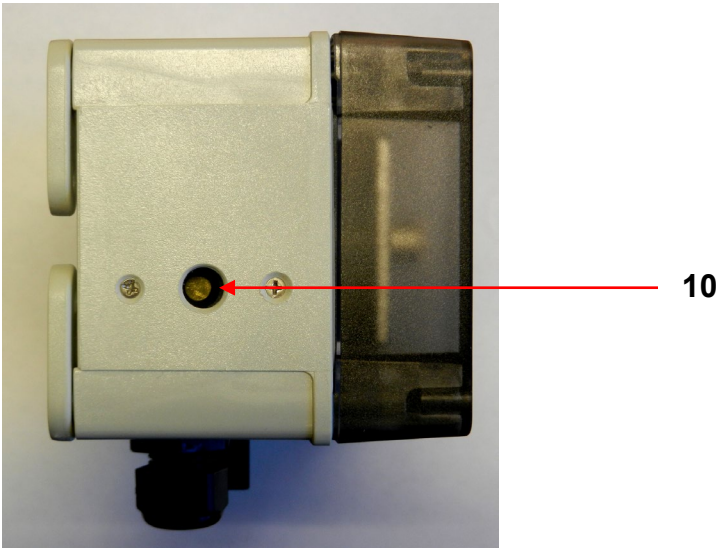

### 1.2.4 Side view of the CO<sub>2</sub> Sensor

**NOTE:** The CO<sub>2</sub> sensor is an NDIR type that is continuously monitoring ambient levels. You will see a blinking orange LED flash approximately every 2 seconds. This is normal.

*The CO<sub>2</sub> sensor and sensor cable are hard wired directly to the main board.*

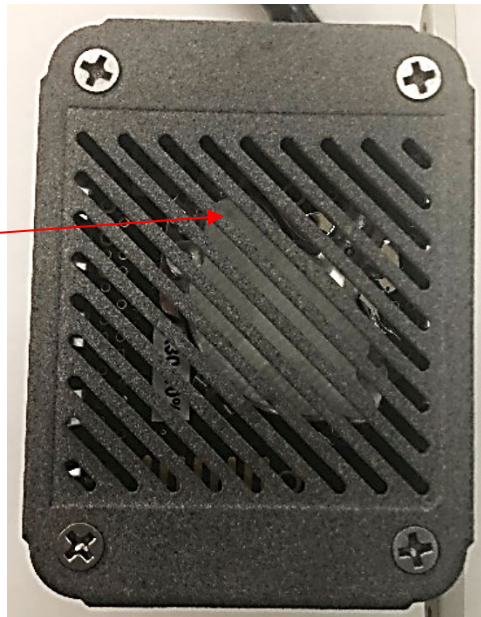

### 1.2.5 Transmitter Interior

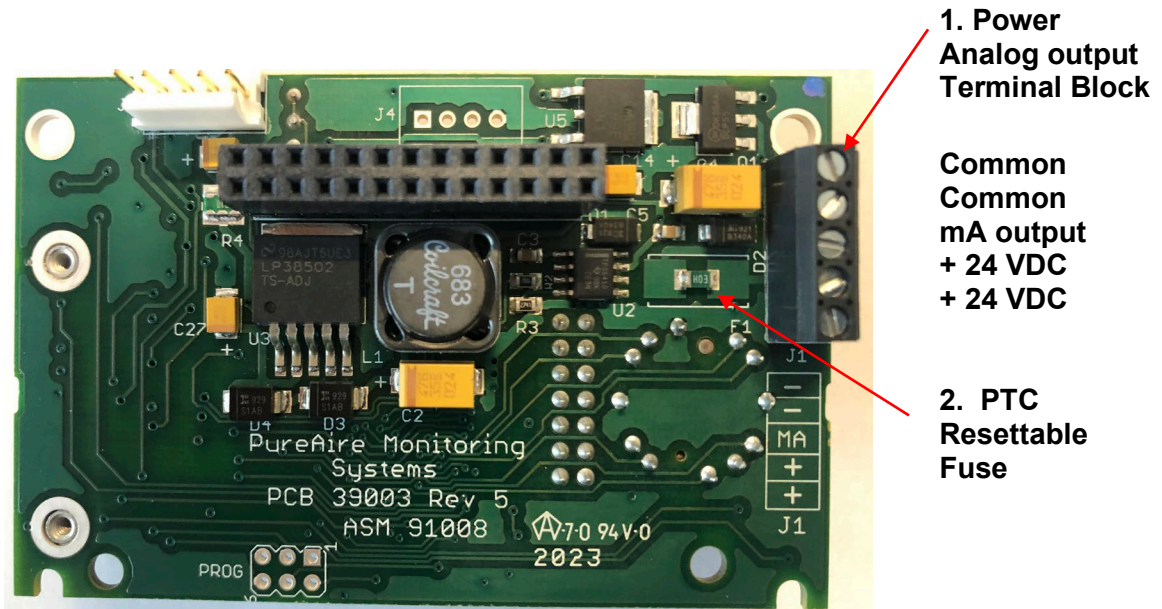

1. Power Analog output Terminal Block

Common  
Common  
mA output  
+ 24 VDC  
+ 24 VDC

2. PTC Resettable Fuse

1. **Power Analog Terminal Block** — This terminal block is where the 24VDC power and 4-20 mA analog output connection is made.
2. **PTC Resettable Fuse** — The PCB is protected with a PTC Fuse that is resettable and Never needs to be replaced. If it trips, you will need to turn power off to the monitor. When power resumes the fuse will reset.

### 1.2.7 Alarm Relay Board

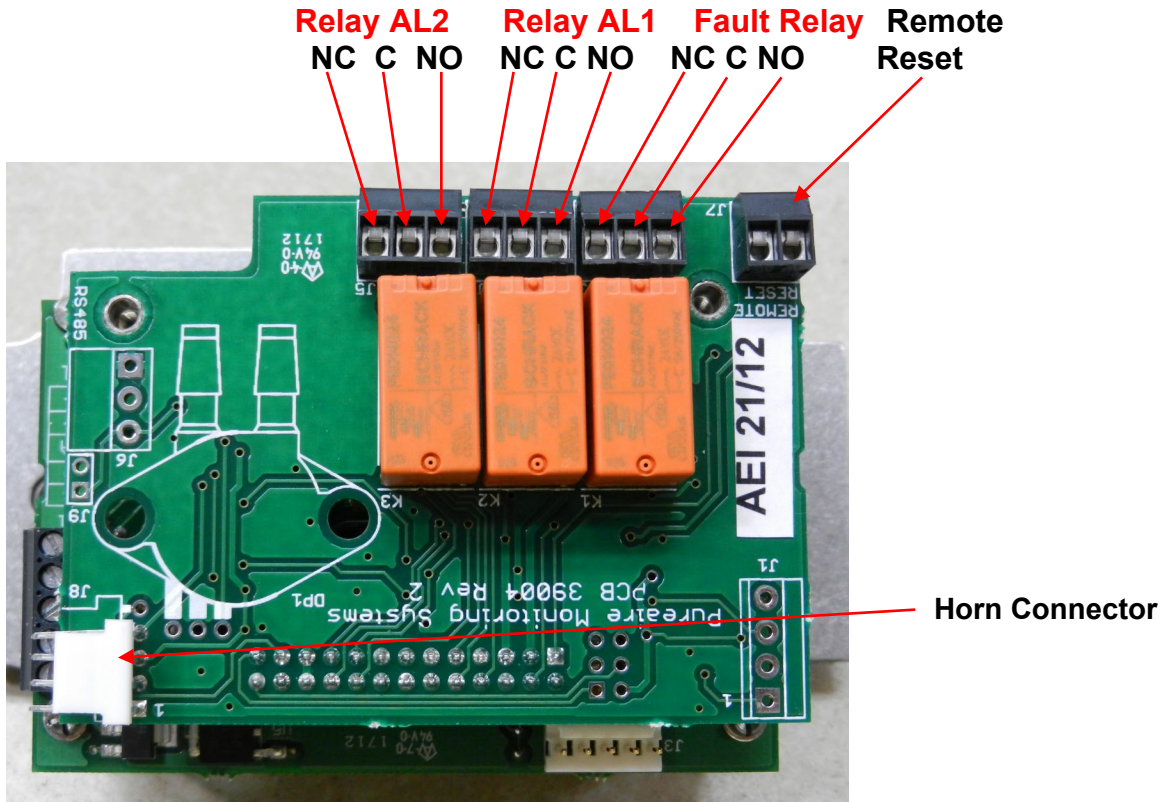

### 1.2.8 Enclosure Mounting Feet

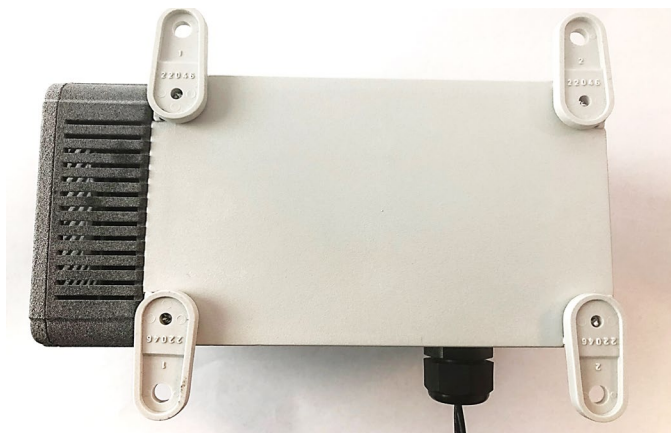

**Mounting Feet can be oriented in any direction**

**Feet can also be removed for mounting the CO<sub>2</sub> monitor flush with a wall or other surface**

## 2: Specifications

---

**NOTE:** For our continual product improvement, all specifications are subject to change without notice.

### 2.1 Performance Specifications Carbon Dioxide Sensor

---

Sensor Type:	Long Life NDIR Sensor <b>0-50,000ppm</b>
Response Time:	Within 1 second of any change in CO <sub>2</sub> .
Accuracy:	Accuracy: ±300 ppm, ±3% of measured value
Fault Indicators:	Loss of VDC power (analog signal drops to 0 mA). Sensor cell failure: Fault relay activated. <b>(Must have Alarm relay option for cell failure to operate)</b>
Operating Temp:	32° to 122°F (0° to +50°C); consult PureAire for lower or higher operating temperatures.
Humidity:	0 to 95% RH.
Environment:	Altitude 2000 m, PSU only UL spec. Pollution Degree 3, Intended for Indoor Use.
CE	EN 61000-3-2:2006 EMC, EN 61000-3-3:2008 EMC, EN61010-1-3-2013 LVD

### 2.2 Gas Detection System

---

Transmitter:	Microprocessor electronics with built-in 3-digit backlit LCD display Joystick operated menus
--------------	---

### 2.3 Signal Outputs

---

Local Display:	Digital display calibrated for Carbon Dioxide. The range is stated on the model label and can also be accessed via the joystick on the front panel. In the measurement mode pushing the joystick down will scroll the gas and range on the display. Push the joystick down again to stop the scrolling and display the gas again.	
Standard	Analog Output:	DC 4-20 mA
	Relay Output:	Dual level user selectable alarm relays and one fault relay Rated, 2amps @ ≤ 24VAC or 24VDC

### 2.4 Electrical Requirements

---

Power:	24 VDC external power. A regulated 24VDC power supply is required.
Consumption:	Approximately 75mA

### 2.5 Physical Characteristics

---

Dimensions:	6.5 (W) x 3.15 (H) x 3.00 (D) inches; 165 x 80 x 76 mm (Max with feet)
Weight:	1.1 pounds (0.5 kg)
Enclosure Type:	General purpose; not intended for explosive atmospheres.

## 2.6 CO<sub>2</sub> System Default Factory settings

The CO<sub>2</sub> Monitor is shipped with factory defaults for the alarm relay settings. The following are the factory defaults:

Menu Function	Factory Default	Menu Defined
<b>Set 4-20mA loop</b>	The mA output is set at the factory using a calibrated Fluke meter.	Use this function to adjust the monitor's 4mA, (Zero) and 20mA, (Span) to your PLC or distributive control system.
<b>Set Formats LED and alarm relay State **</b>	Alarm 1 = Normal Alarm 2 = Normal Fault = Normal	Do you want the relays to energize, (normal) or de-energize, (fail safe) when the alarm activates?
<b>Set Alarm Threshold Polarity</b>	Alarm 1 = Normal Alarm 2 = Normal Audio = Not Available	Do you want to alarm at a level higher, (normal) or lower, (inverted) than the alarm threshold?
<b>Set Latching</b>	Alarm 1 = Non-latching Alarm 2 = Non-latching Audio = Non-latching	Do you want the alarm to automatically reset? (non-latching) or do you want to manually reset the alarm? (latching)
<b>Alarm Delay</b>	Alarm = 5 seconds Displayed as 05	How long do you want to wait until the alarms activate?
<b>Zero Suppression</b>	0.0%	<b>This function is Not Enabled on the CO<sub>2</sub> monitor.</b>
<b>Set Alarm Thresholds</b>	Alarm 1 = 5,000ppm Alarm 2 = 10,000ppm	At what level do you want to alarm?
<b>Set Alarm Hysteresis</b>	Alarm 1 = 00 PPM Alarm 2 = 00 PPM	For use when using the CO <sub>2</sub> monitor for control of valves and process.
<b>Sensor Adjustment</b>	Set CO <sub>2</sub> Sensor span CO <sub>2</sub> set to autocal on CO <sub>2</sub> set to autocal off Calibrate CO <sub>2</sub> to 400ppm	For use when manually gas calibrating the CO <sub>2</sub> monitor. See Section 6.2
<b>Manage Passwords</b>	Factory default is <b>557</b>	For use when changing the password from factory default to a new password of your choice.

**NOTE:** The built in relay settings may be changed by the user in the field. Refer to Section 5.5.2

**\*\* NOTE:** The LED indicators on the front panel are connected directly to the alarm relays.

# 3: Installation

## 3.1 Site Requirements

The  $CO_2$  monitor enclosure should be mounted in an area free of vibration and electrical noise or interference. If possible, avoid areas with high temperatures or condensing humidity.

**WARNING:** *The  $CO_2$  monitor is not designed for installation in hazardous areas. Consult PureAire for information on enclosures for use in hazardous environments.*

## 3.2 Mounting

### 3.2.1 Transmitter Enclosure

The  $CO_2$  monitor is designed primarily for wall mounting and should be installed at a height convenient for operation, maintenance, and viewing of the instrument display. The following is a drawing of the mounting dimensions.



### 3.2.2 $CO_2$ monitor

The transmitter and sensor should be installed in a location where gas leaks are likely to occur or where released gases may accumulate. It should be mounted no closer than 12 inches above floor level. Airflow within the monitored area, the characteristics of the gas (lighter or heavier than air), and the position of workstations and personnel should all be considered in determining the most suitable installation location.

### 3.3 Wiring

The  $CO_2$  monitor requires a single, 3-wire shielded cable for analog output and 24 VDC power input. A three-wire shielded cable; 3-conductor, 18 AWG stranded General Cable E2203S.30.860, or equivalent is recommended for the connection. The analog out and VDC power in connections are made on the terminal block inside the transmitter housing.

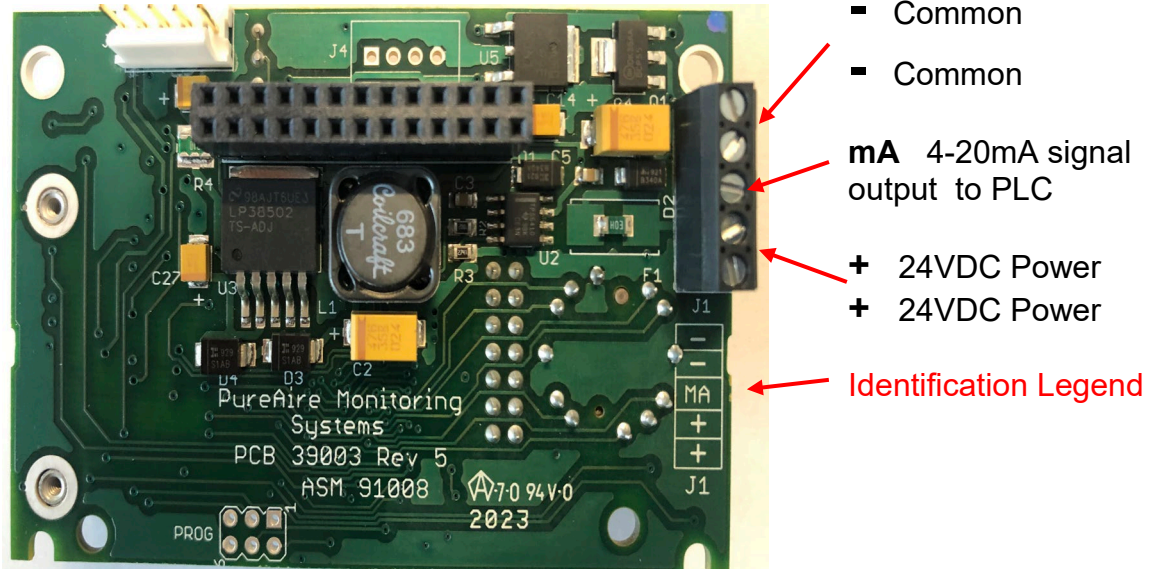

These connections are made as follows:

Pin #	Connection	Description
-	Common (Signal Ground)	0V
-	Common (Signal Ground)	0V
MA	Signal Out	DC 4-20mA Output
+	Power	DC + 24V Input
+	Power	DC + 24V Input

**NOTE:** *PureAir has added additional contacts for +24VDC power and Common to accommodate additional wiring for remote horns and strobes*

### 3.4 Initial Startup

---

Once installation of the gas detector has been completed, it is ready for startup. The following procedures should be performed before putting the instrument into operation:

1. Check the integrity of all wiring.
2. Apply 24 VDC power.

The instrument should now be powered up. Upon power up, the **CO<sub>2</sub>** monitor LCD displays the PureAire logo and then displays CO<sub>2</sub> on the top line and the actual PPM reading on the bottom line. The monitor will also output the proper mA signal to remote devices..

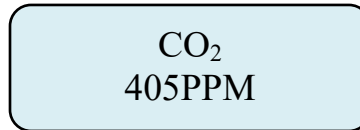

**NOTE:** Ambient outdoor carbon dioxide levels are approximately 400ppm

## 4: Normal Operation

The  $CO_2$  monitor is a single point monitor designed for the continuous detection and measurement of ambient carbon dioxide concentration levels.

### 4.1 Signal Outputs

The  $CO_2$  monitor outputs a continuous 4-20 mA analog signal proportional to the measured concentration of carbon dioxide. For  $CO_2$ , 4 mA represents 0 PPM  $CO_2$  and 20 mA represents 50,000 PPM  $CO_2$  which is the full range for carbon dioxide. In the event of a system fault, a specific factory defined code will be displayed on the local digital display. This code will indicate the exact nature of the system fault.

### 4.2 Instrument Faults

The  $CO_2$  monitor incorporates a several self-checking features to ensure reliable operation. If a fault condition is detected, the analog output signal is altered: A few common error codes are displayed in the following table:

Condition	Analog Signal
**Supply Voltage Out of Range Fault code 16	Analog output drops to 2 mA Fault Relay activates
Transmitter cable cut	Analog output drops to 0 mA
$CO_2$ Cell complete failure Fault code 128	Analog output drops to 2 mA
EEPROM Fault 08	Analog output drops to 2mA Fault Relay activates
$CO_2$ sensor not responding Fault code F01	Analog output drops to 2mA Fault Relay activates

**NOTE: All system faults are displayed on the front panel. Each fault has its own specific code to identify the specific problem. Please contact PureAire whenever a fault is displayed.**

**\*\* When using your own power supply please ensure that the voltage is regulated to 24VDC +/- 0.5 volts. If the voltage is too low or high you will activate a "Supply Voltage Out of Range fault and disable the monitor.**

### 4.3 Routine Maintenance Schedule

Continuous gas detection systems depended upon to measure and detect hazardous gas leaks in the workplace requires periodic maintenance to ensure proper operation. The frequency with which this routine maintenance is required depends on the environment. The following table is intended to serve as a general guideline for routine maintenance. The conditions in your application, as well as your organization's maintenance policies, will ultimately determine the best routine maintenance schedule for your equipment. Routine Visual Checks

Items to check	Check for power and proper operation
Condition / status when operating properly	Unit should be outputting approximately 4.6 mA signal when the carbon dioxide is at ambient 400ppm. The LCD digital display should also indicate approximately 405 ppm level when the carbon dioxide level is at ambient.

### 4.3.2 Recommended Routine Maintenance Schedule

Routine Visual Checks	Every 6 - 12 months
Sensor Verification with nitrogen	Every 6 - 12 months**

The ambient CO<sub>2</sub> level is 400ppm and the sensor provides automatic baseline adjustments to ambient levels on a regular time schedule. However, the CO<sub>2</sub> sensor can be manually calibrated by using span gas. See section 6.3 for how to manually calibrate the CO<sub>2</sub> sensor.

### 4.4 Loss of Power Indicator

---

In the event the CO<sub>2</sub> monitor loses 24VDC power, the 4-20 mA analog output signal drops to 0mA. The LCD display will also display a blank screen.

### 4.5 Alarm Reset

---

If the CO<sub>2</sub> monitor is supplied with individual alarm relays. Whenever the monitor's alarms are activated, the built-in alarm relays, panel mounted LED's and audio horn will also activate. When the relay settings are non-latching, the alarm relays, LEDs, and horn will automatically reset. If the relay settings are latching, then a manual reset of the alarms are required. Resetting the alarms can be performed through use of the joystick or using the remote reset function.

Joystick – You must enter the password **557**, to enter the reset function. After the password is entered and accepted, push the joystick in; (enter) to reset the alarms.

Remote Reset – See section 1.2.7. The alarm relay board has a two-pin connector for wiring to a remote switch. When connected to a switch, this remote reset will bypass the joystick and a password will not be needed to reset the alarms.

**NOTE:** The carbon dioxide levels must recover above the alarm thresholds before the horn can be reset from the remote reset switch or joystick.

## 5: CO<sub>2</sub> Monitor Programming

---

The CO<sub>2</sub> monitor is supplied with user selectable settings to adjust the alarm settings, 4 and 20mA output and minor sensor adjustments. The settings are arranged in menus that are accessed by moving the joystick. To access the menus a factory set password is used.

**NOTE:** The CO<sub>2</sub> monitor will continuously monitor levels while accessing the menus. **The alarm, fault relays and mA output are all active and online while making any changes to the menus.**

### 5.1 Joystick Operation

---

The CO<sub>2</sub> monitor uses a 4-position joystick with a center pushbutton for selecting menus and changing values. The joystick is programmed to standard protocol as follows:

**NOTE:** *The joystick has a built-in delay to prevent accidental tampering of the menus. deliberate entries are required.*

**CAUTION:** *Only qualified personnel should perform programming, maintenance, and sensor verification*

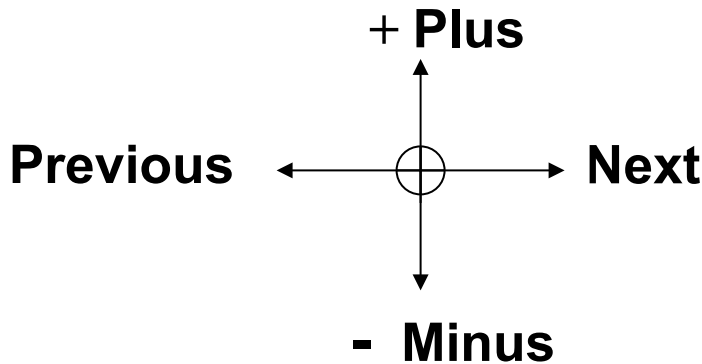

**Plus** – Pushing the joystick in this direction increases the value

**Minus** – Pushing the joystick in this direction decreases the value

**Next** – Pushing the joystick in this direction moves you to the next level of the menu hierarchy.

**Previous** – Pushing the joystick in this direction takes you out to the last level of menu hierarchy.

**Enter** – Pushing the joystick directly in the center enters the information into the microprocessor

## 5.2 Program Flowchart

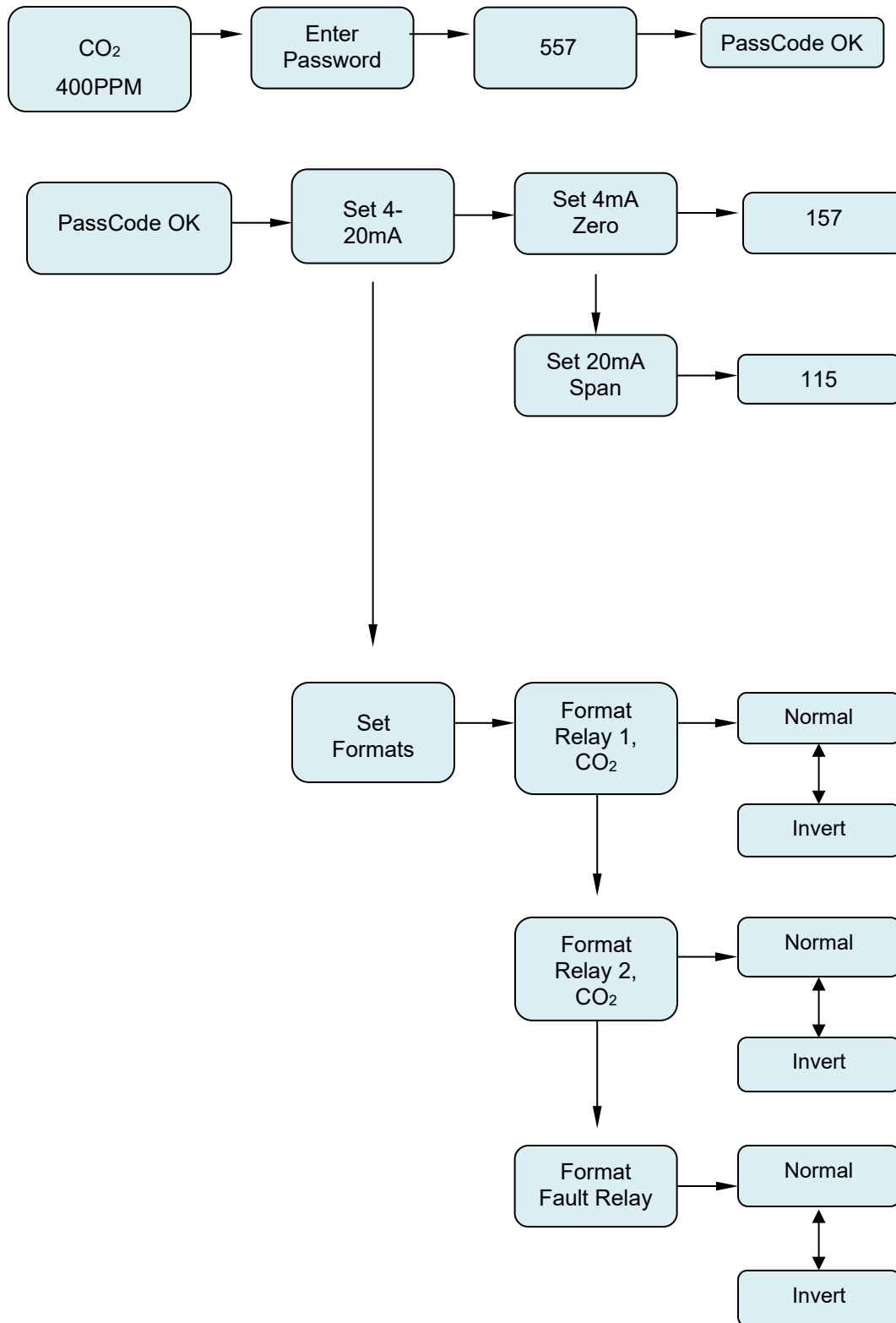

**NOTE:** All numerical values shown are only examples and are not Factory Defaults

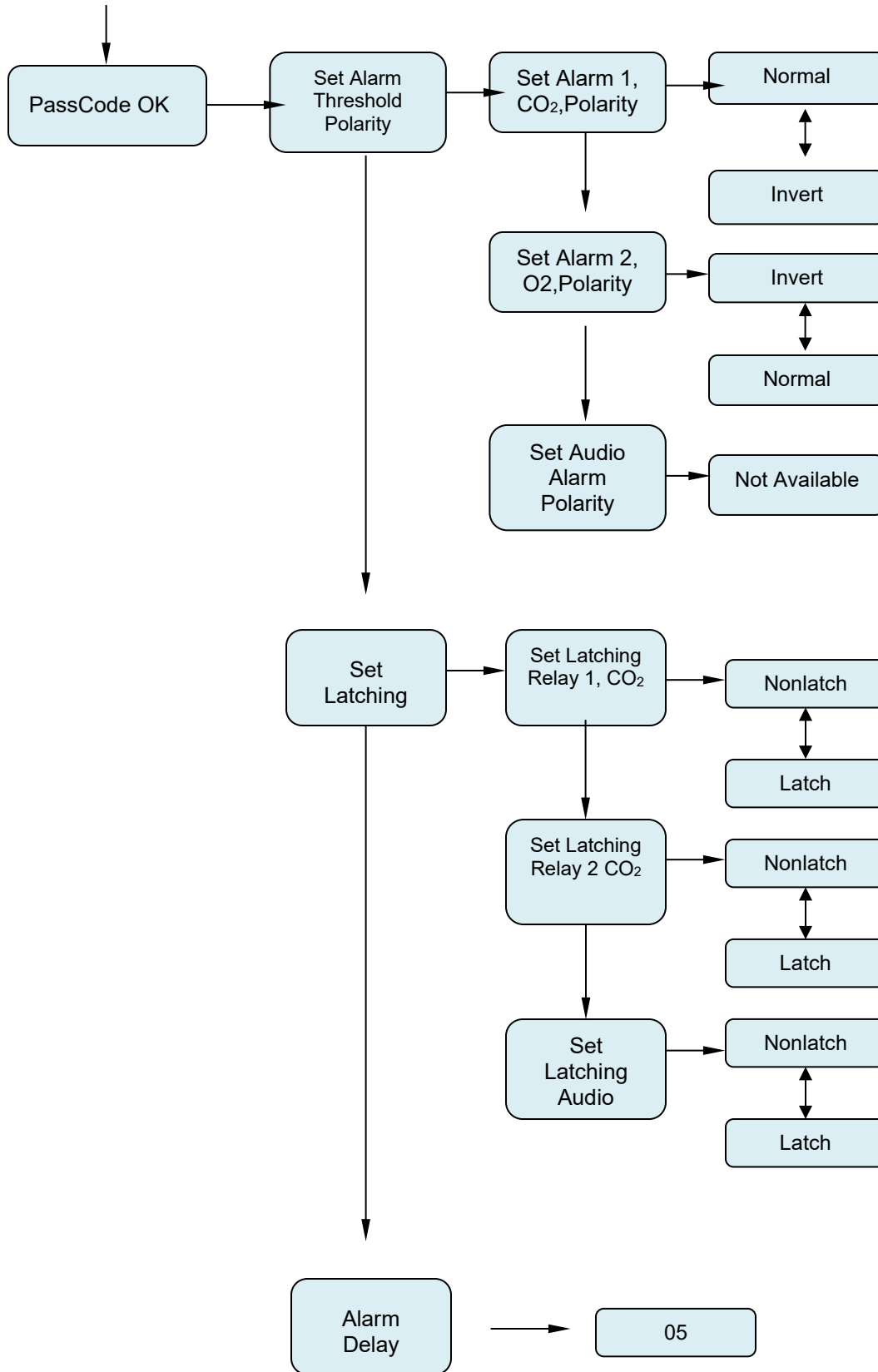

**NOTE:** Factory defaults are:

CO<sub>2</sub> polarity is **Normal**

*The audio horn will activate when the polarity is changed to **Invert***

**NOTE:** All numerical values shown are only examples and are not Factory Defaults

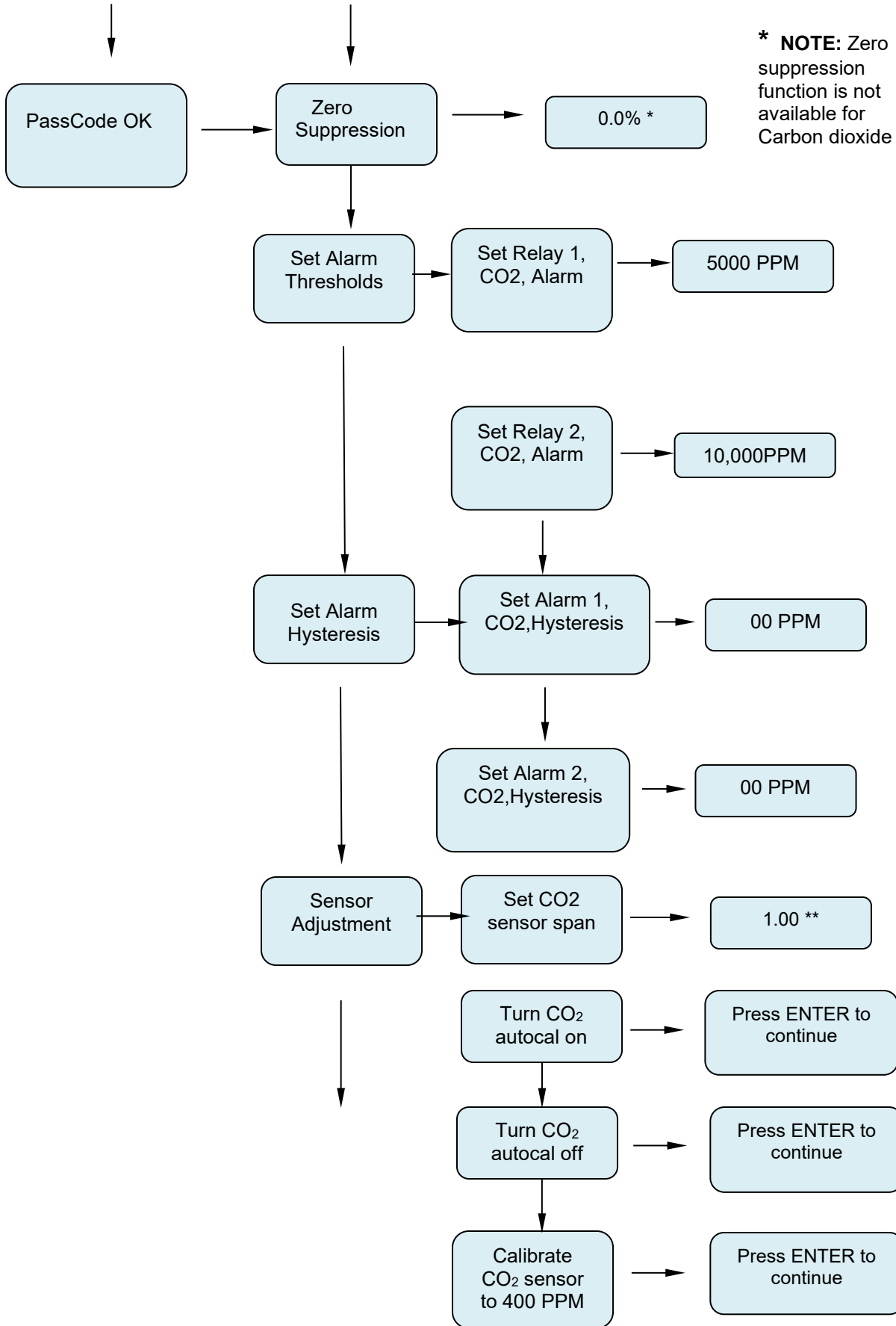

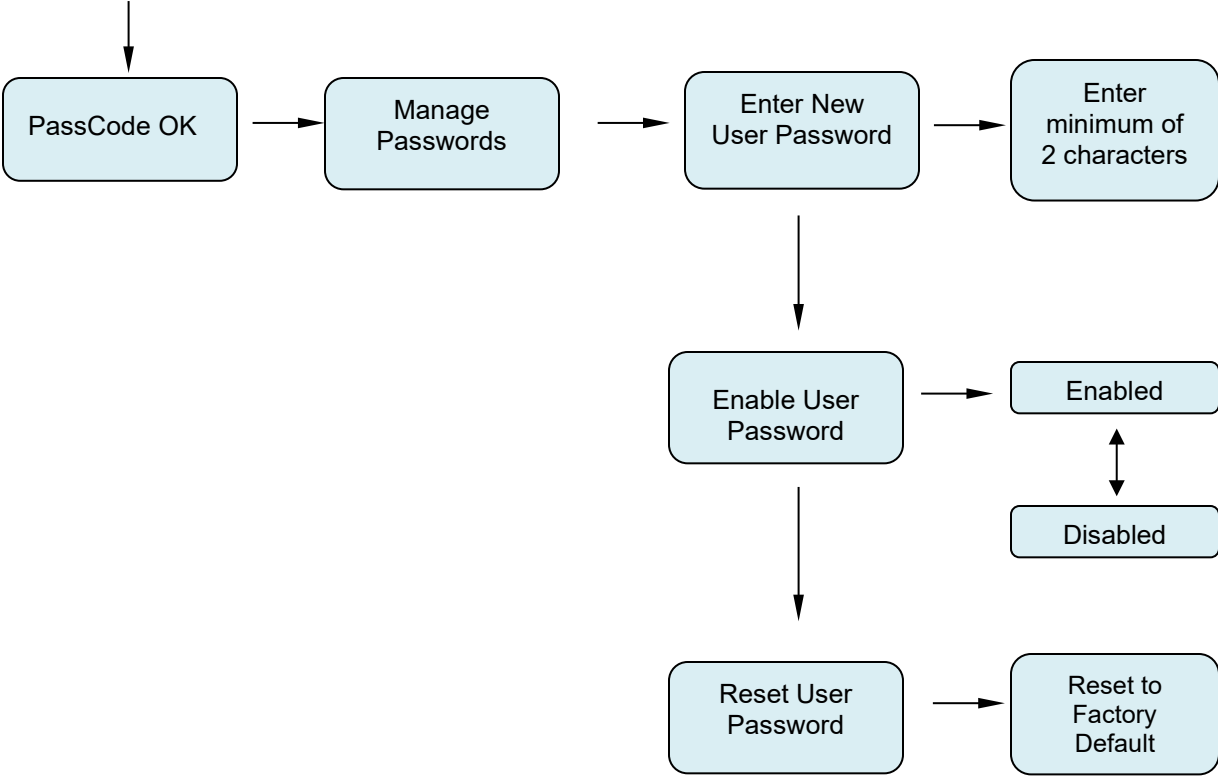

## 5.3 Entering the Password

---

The **CO2** Air Check monitor is supplied with a factory set password to prevent unauthorized access to the menus. **The Password is 557.** The following explains how to enter the password.

1. Push the joystick once to the right. **Enter Password** will scroll on the first line of the digital display. The second line will still display the current carbon dioxide level.

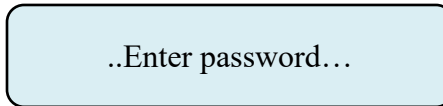

..Enter password...

2. Push the joystick again once more to the right to enter the input screen. **The letter A will appear and flash.**

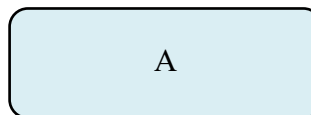

A

**NOTE:** *The display has characters that start with A through Z and 0 through 9. Pushing the joystick up or down will permit you to scroll through the alphanumeric characters.*

3. Push the joystick up or down to enter the first digit. The display is an alphanumeric display and toggles from A through Z followed by 0 to 9. The character to be entered will flash.

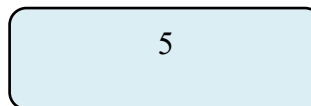

5

4. Push the joystick again to the right to select the second entry. Push the joystick up or down to select the second digit. The character being entered will flash and the first character entered will remain lit.

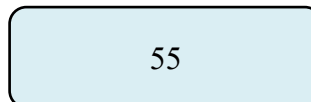

55

5. Push the joystick again to the right to select the third entry. Push the joystick up or down to select the third and final digit. The character being entered will flash and the first and second characters entered will remain lit. You are now ready to enter the 3-digit password.

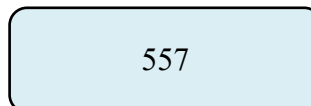

557

6. Push the joystick in the center to enter the password. If you entered it correctly the display will scroll **Password OK.**

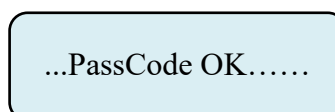

...PassCode OK.....

**NOTE:** If an incorrect password has been entered, the display will indicate **Password Failed.** Push the joystick to the left to access the monitoring mode. From this mode you can reenter the password again.

## 5.4 Changing the User Password

---

The  $CO_2$  Air Check monitor is supplied with a factory set password to prevent unauthorized access to the menus. The user can change this password and the following explains how to change the password.

1. Push the joystick down to access the **Manage Passwords Menu**. **Manage Passwords** will scroll on the first line of the digital display. The second line will still display the current carbon dioxide level.



..Manage Passwords...

2. Push the joystick to the right to enter the input screen. **Enter New User Password** will scroll on the first line of the digital display



...Enter New User Password...

3. Push the joystick to the right to enter the input screen. **The letter A will appear and flash.**



A

**NOTE:** *The display has characters that start with A through Z and 0 through 9. Pushing the joystick up or down will permit you to scroll through the alphanumeric characters.*

4. Push the joystick up or down to enter the first digit. The display is an alphanumeric display and toggles from A through Z followed by 0 to 9. The character to be entered will flash.



2

5. Push the joystick again to the right to select the second entry. Push the joystick up or down to select the second digit. The character being entered will flash and the first character entered will remain lit.



25

6. Push the joystick again to the right to select the third entry. Push the joystick up or down to select the third and final digit. The character being entered will flash and the first and second characters entered will remain lit. You are now ready to enter the 3-digit password.

253

7. Push the joystick in the center to enter the password. This will display the next command, **Re-Enter New Password**

...Re-Enter New Password...

8. Push the joystick to the right to enter the input screen. **The letter A will appear and flash.**

A

9. Push the joystick up or down to enter the first digit. The display is an alphanumeric display and toggles from A through Z followed by 0 to 9. The character to be entered will flash.

2

10. Push the joystick again to the right to select the second entry. Push the joystick up or down to select the second digit. The character being entered will flash and the first character entered will remain lit.

25

11. Push the joystick again to the right to select the third entry. Push the joystick up or down to select the third and final digit. The character being entered will flash and the first and second characters entered will remain lit. You are now ready to enter the 3-digit password.

253

12. Push the joystick in the center to enter the password. If you entered it correctly the display will scroll **“New Password Entry OK”**.

...New Password Entry OK...

**NOTE:** If on the second entry the password entered was not the same as the first, the display will take you back to the “Re-enter Password Screen”. You will need to repeat steps 2 through 11. If you do not enter the password correctly, the monitor remembers the last password that was properly input.

### 5.4.1 Enable User Password

This menu permits the user to activate or disable the password function on the Carbon Dioxide monitor. Push the joystick down. “**Enable User Password**” will scroll on the first line of the digital display

...Enable User Password...

Push the joystick right to display the status. If enabled it will display “**Enabled**”

Enabled

Push the joystick up or down to change the status. Once enabled or disabled is selected, Push the joystick in (like a doorbell) to enter the new status. If correctly entered the Display will scroll “**Enable User Password**”

...Enable User Password...

### 5.4.2 Reset User Password

This menu permits you to reset the password back to 557, as set at the factory.

...Reset User Password...

Push the joystick right to display the menu, “**Reset to factory Default**”.

...Password Reset to factory Default...

Push the joystick in, (like a doorbell) to reset the password back to 557.  
Push the joystick left 4 times to go back to the measuring mode.

**NOTE: If you lose your password please contact PureAire with your serial number or DTM number**

CO<sub>2</sub>  
405PPM

## 5.5 Entering the Menus

---

The  $CO_2$  monitor is supplied with main menus with sub menus to adjust mA outputs and alarm relay settings.

### 5.5.1 Set 4-20mA loop

.Set 4-20mA loop..

This main menu will permit the adjusting of the 4mA and 20mA output from the  $CO_2$  monitor. This menu will provide the function that will send an actual output between 4mA and 20 mA to test any remote control and alarm system attached to the  $CO_2$  monitor.

**NOTE:** *To read the mA output,  $CO_2$  monitor must either be connected to a remote PLC controller or SCADA system. You can also connect the  $CO_2$  monitor to a DC ammeter to read the mA output. Please consult PureAire for more information.*

From this main menu, pushing the joystick to the right will select the sub menu and the digital display will scroll the following:

..Set 4mA zero...

This is the menu at which to adjust the 4mA output being sent from the  $CO_2$  Monitor.

To change this value, push the joystick right to display the 4 mA setting. The display will indicate a value between 0 and 255 counts. Pushing the joystick up increases the value and pushing the joystick down decreases the value. The 4mA output being sent from the  $CO_2$  monitor will change as the number on the digital display changes.

128  
470PPM

Push the joystick to the left to enter the value and bring you back to the pervious Main menu. The digital display will scroll the following:

...Set 4mA zero.....

Push the joystick down to access the next sub menu; **Set 20mA Span will scroll.**

...Set 20mA Span...

This is the menu at which to adjust the 20mA output being sent from the CO<sub>2</sub> Monitor.

To change this value, push the joystick right to display the 20mA span setting. The display will indicate a value between 0 and 255 counts. Pushing the joystick up increases the value and pushing the joystick down decreases the value. The 20mA output being sent from the CO<sub>2</sub> monitor will change as the number on the digital display changes.

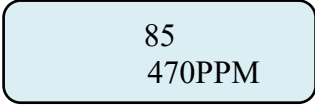

85  
470PPM

Push the joystick to the left to enter the value and bring you back to the pervious Main menu. The digital display will scroll the following:



...Set 20mA span.....

### 5.5.1 Set Formats

This is the menu at which to adjust the relay states for the gas alarm relays and the individual instrument fault relay.

Push the joystick down to access the next main menu, **Set Formats**. The display will scroll the following:



...Set Formats...

This menu will permit the setting of the two alarm relays and the fault relay settings from normally de-energized state, **Normal**, to normally energized state, **Inverted**.

From this main menu, pushing the joystick to the right will select the sub menu and the digital display will scroll the following:



..Format Relay 1 CO<sub>2</sub>...

This is the menu at which to adjust the CO<sub>2</sub> alarm relay state..

To change this value, push the joystick right to display the relay state. The display will Indicate **NORMAL**. This is the factory default state for the alarm relay. Pushing the joystick down will change the relay state from INVERT to NORMAL.

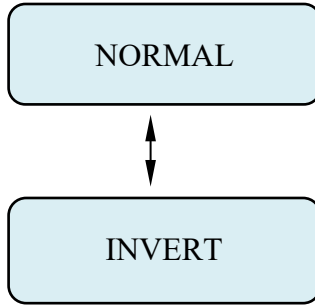

**NOTE: When the CO<sub>2</sub> relay state is changed to INVERT, the Orange alarm LED will illuminate.**

After entering the relay state push the joystick left to enter the setting. The display will scroll the following:



From this main menu, pushing the joystick down will select the next sub menu to adjust the second alarm relay state. The digital display will scroll the following:

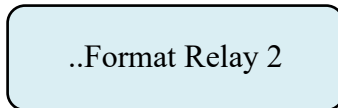

To change this value, push the joystick right to display the relay state. The display will indicate **NORMAL**. This is the factory default state for the alarm relay. Pushing the joystick down will change the relay state from NORMAL to INVERT.

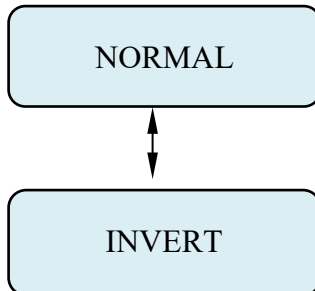

**NOTE: When the CO<sub>2</sub> relay state is changed to INVERT, the Red alarm LED will illuminate.**

After entering the relay state push the joystick left to enter the setting. The display will scroll the following:

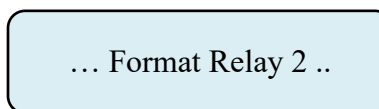

From this main menu, pushing the joystick down will select the next sub menu to adjust

the Fault alarm relay state. The digital display will scroll the following:

..Format Fault Relay...

To change this value, push the joystick right to display the relay state. The display will indicate **NORMAL**. This is the factory default state for the fault relay. Pushing the joystick down will change the relay state from **NORMAL** to **INVERT**.

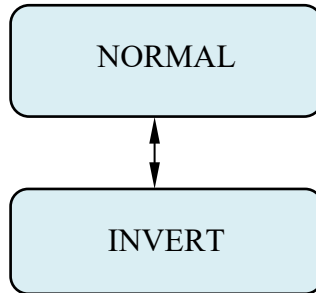

**NOTE: When the Fault relay state is changed to INVERT, the Yellow alarm LED will illuminate.**

After entering the relay state push the joystick left to enter the setting. The display will scroll the following:

..Format Fault Relay...

Push the joystick left again to get back to the next menu. The display will scroll the following:

...Set Formats...

### 5.5.2 Set Alarm Threshold Polarity

Alarm Threshold Polarity determines if an alarm concentration is set above or below a threshold value. For example, if an alarm of 19.0% for oxygen is selected, the Alarm Threshold Polarity must be set to **Invert** for the monitors alarm to activate when the reading goes below 19.0%. For CO<sub>2</sub> gases selecting a **Normal** setting for the Alarm Threshold Polarity means that the system will alarm when the gas concentration exceeds, goes above, an alarm set point. This menu will permit the selection of the alarm polarity. To access this menu from the “Set Formats” menu, push the joystick down to display the **Set Alarm Threshold Polarity** adjustment menu. This will scroll on the digital display.

..Set Alarm Threshold Priority..

Push the joystick right to access the first sub menu; **Set Alarm 1 CO<sub>2</sub> Polarity** will scroll on the display. This is the menu at which to adjust the CO<sub>2</sub> alarm polarity state on the CO<sub>2</sub> Monitor.

..Set Alarm 1, CO<sub>2</sub>, Polarity...

To change this value, push the joystick right to display the relay state. The display will indicate **NORMAL**. Pushing the joystick down will change the relay state from **NORMAL** to **INVERT**.

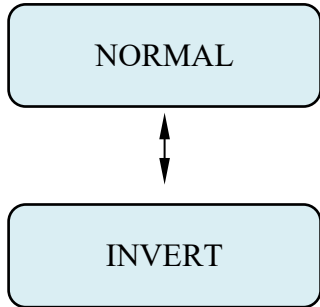

**NOTE: When the CO<sub>2</sub> relay state is changed to INVERT, the internal horn will sound.**

After entering the polarity push the joystick left to enter the setting. The display will scroll the following:

..Set Alarm 1, CO<sub>2</sub>, Polarity..

Push the joystick down to access the next sub menu; **Set Alarm 2, CO<sub>2</sub>, Polarity** will scroll on the display. This is the menu at which to adjust the second level alarm polarity state on the CO<sub>2</sub> Monitor.

..Set Alarm 2, O<sub>2</sub>, Polarity ..

To change this value, push the joystick right to display the relay state. The display will indicate **INVERT**. Pushing the joystick down will change the relay state from **INVERT** to **NORMAL**.

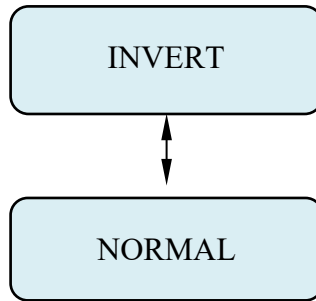

**NOTE: When the CO<sub>2</sub> relay state is changed to NORMAL, the internal horn will sound..**

After entering the polarity push the joystick left to enter the setting. The display will scroll the following:

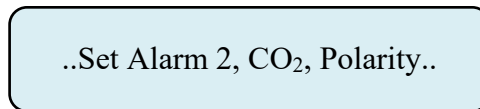

**NOTE: The Set Audio Alarm Polarity is not available on the CO<sub>2</sub> monitor**

### 5.5.3 Set Latching

This is the menu at which to adjust the relay alarm state for the CO<sub>2</sub> alarm relays and the individual instrument fault relay. The selection permits setting the relays to a latching or non-latching state. In a latching state, the relay will remain activated until the user manually selects the Enter Key. In a non-latching state, the alarm relay will automatically reset once the gas concentration has returned to below the alarm settings



From this main menu, pushing the joystick to the right will select the sub menu and the digital display will scroll the following:

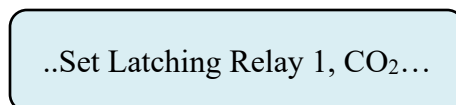

This is the menu at which to adjust the CO<sub>2</sub> alarm relay state on the CO<sub>2</sub> Monitor.

To change this value, push the joystick right to display the relay state. The display will indicate **NONLATCH**. Pushing the joystick down will change the relay state from NONLATCHING to LATCHING.

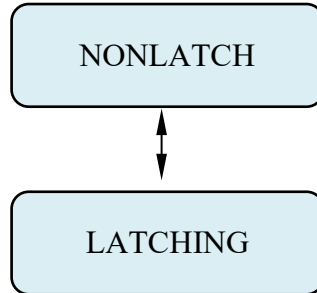

After entering the relay setting push the joystick left to enter the setting. The display will scroll the following:

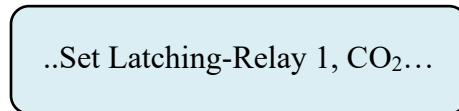

Push the joystick down to access the next sub menu; **Set Latching-Relay 2, CO<sub>2</sub>**, will scroll on the display. This is the menu at which to adjust the second CO<sub>2</sub> alarm relay state on the CO<sub>2</sub> Monitor.

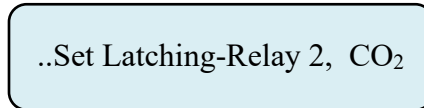

To change this value, push the joystick right to display the relay state. The display will indicate **NONLATCH**. Pushing the joystick down will change the relay state from NONLATCH to LATCHING.

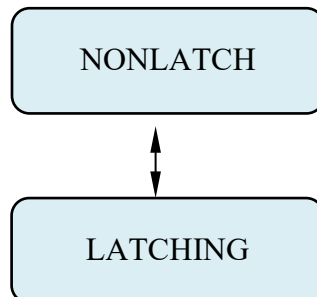

After entering the relay setting push the joystick left to enter the setting. The display will scroll the following:

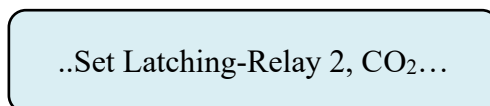

Push the joystick down to access the next sub menu; **Set Latching-Audio Alarm** will scroll on the display. This is the menu at which to adjust the Audio alarm relay state on the CO<sub>2</sub> Monitor.

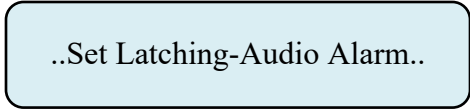

To change this value, push the joystick right to display the relay state. The display will indicate **NONLATCH**. Pushing the joystick down will change the relay state from NONLATCH to LATCHING.

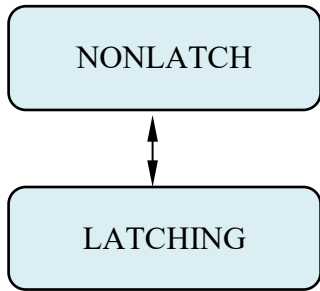

After entering the relay setting push the joystick left to enter the setting. The display will scroll the following:

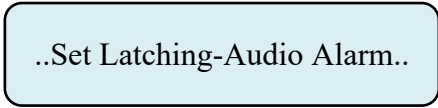

#### 5.5.4 Resetting a Latching Alarm

To reset a latching alarm relay, you must enter the password correctly and then push the joystick down to enter the reset command. The CO<sub>2</sub> monitor also has an internal 2-pin terminal block for connecting a remote reset switch. (See Alarm Relay board, section 1.2.7)

#### 5.5.5 Set Alarm Delay

Push the joystick down to access the next main menu, **Alarm Delay**. The display will scroll the following:

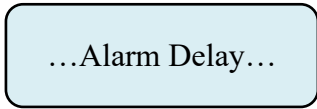

This is the amount of time an alarm level concentration of either oxygen or carbon dioxide must be present before the instrument's gas concentration alarms will be activated. This menu will permit setting a user selected time delay for activating the CO<sub>2</sub> alarm.

You can select from 0 seconds up to 255 seconds after an alarm level has been exceeded Before the alarm relays to activate.

To change this value, push the joystick right to display the time screen. The display will indicate a value between 0 and 255 seconds. Pushing the joystick up increases the value and pushing the joystick down decreases the value



After entering the relay setting push the joystick left to enter the setting. The display will scroll the following:



**NOTE:** *The alarm delay is only available for the CO2 alarms 1 and 2. There is no delay for the fault relay. Any system fault will immediately activate the Fault Relay.*

### 5.5.6 Set Zero Suppression

This function not used on the CO<sub>2</sub> monitor. It is only used to decrease the sensitivity of selected toxic and corrosive gas sensors. It is totally disabled in the Dual monitor.

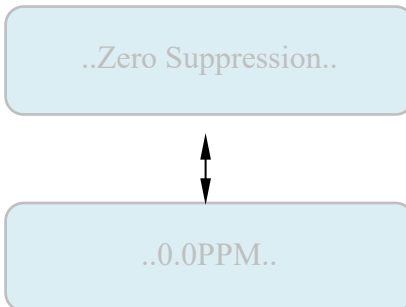

### 5.5.7 Set Alarm Thresholds

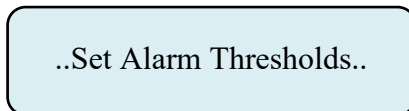

This main menu will permit adjusting the Carbon Dioxide ppm level that will activate their respective alarm relays. It will also activate the internal audio horn.

From this main menu, pushing the joystick to the right will select the first sub menu and the digital display will scroll the following: **Set Relay 1, CO<sub>2</sub>, Alarm Threshold.**

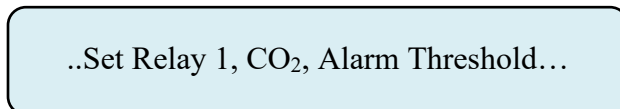

This is the gas concentration at which the CO<sub>2</sub> level must be displaying to activate the alarm. To change the displayed value, push the joystick to the right to display the CO<sub>2</sub> level alarm setting. The display will indicate a value between 0 ppm and 50,000 ppm.

Pushing the joystick up increases the value and pushing the joystick down decreases the value.

5000PPM

After entering the alarm setting push the joystick left to enter the setting. The display will scroll the following:

..Set Relay 1, CO<sub>2</sub>, Alarm Threshold...

Push the joystick down to access the next sub menu; **Set Relay 2 Alarm Threshold**, will scroll on the digital display.

..Set Relay 2, CO<sub>2</sub>, Alarm Threshold...

This is the gas concentration at which the second CO<sub>2</sub> level must be displaying to activate the alarm. To change the displayed value, push the joystick to the right to display the CO<sub>2</sub> level alarm setting. The display will indicate a value between 0 and 50,000 ppm.

Pushing the joystick up increases the value and pushing the joystick down decreases the value.

10,000PPM

After entering the alarm setting push the joystick left to enter the setting. The display will scroll the following:

..Set Relay 2, CO<sub>2</sub>, Alarm Threshold...

Push the joystick left once to return to the **Set Alarm Thresholds menu**. The display will scroll the following:

..Set Alarm Thresholds..

### 5.5.8 Set Alarm Hysteresis

PureAire's CO<sub>2</sub> monitor may be used as a control system. When used to regulate carbon dioxide levels the need of a dead band, "hysteresis" may be required for the alarm relays. This menu will permit the setting of the alarm hysteresis to a desired concentration of Carbon Dioxide. When using hysteresis, the alarm set point now becomes an average alarm setting for an action to occur. When adding the hysteresis value to the alarm set point, this then defines the alarm and dead band for an action to occur.

For example, if you require a valve to close at 5,000ppm level and to reopen again at 5,050 ppm, you will set the Alarm Threshold at 5000ppm and set the hysteresis value at 50ppm.

Average Alarm set point = 5,000 set the Hysteresis to 50ppm= Valve Off (5,050ppm)

To access this menu, push the joystick down to display the **Set Alarm Hysteresis** menu. This will scroll on the digital display.

..Set Alarm Hysteresis...

Push the joystick right to access the **Set Alarm 1, CO<sub>2</sub>, Hysteresis**.

..Set Alarm 1, CO<sub>2</sub>, Hysteresis...

It will display a value 00 PPM, (factory default). Pushing the joystick up increases the CO<sub>2</sub> PPM up to a maximum value of 1000 PPM. Adjust the digital display until the desired hysteresis value is selected.

50 PPM

After entering the alarm setting push the joystick left to enter the setting. The display will scroll the following:

..Set Alarm 1, CO<sub>2</sub>, Hysteresis...

Push the joystick down to access the next sub menu; **Set Alarm 2, CO<sub>2</sub>, Hysteresis.** on the digital display.

..Set Alarm 2, CO<sub>2</sub>, Hysteresis...

It will display a value 00 PPM, (factory default). Pushing the joystick up increases the CO<sub>2</sub> PPM up to a maximum value of 1000 PPM. Adjust the digital display until the desired hysteresis value is selected.

50 PPM

After entering the alarm setting push the joystick left to enter the setting. The display will scroll the following:

..Set Alarm 2, CO<sub>2</sub>, Hysteresis...

Pushing the joystick again to the right will display a value 0.0%. Pushing the joystick up increases the percentage up to a maximum value of 2.5%. Adjust the digital display until the desired hysteresis value is selected.

..Set Alarm Hysteresis...

### 5.5.9 Auto Calibrate feature for CO<sub>2</sub> NDIR sensor

The CO<sub>2</sub> sensor is set to automatically calibrate itself to the ambient carbon dioxide level on earth. The ambient CO<sub>2</sub> level is 400 PPM. The CO<sub>2</sub> monitor has a menu that permits you to activate this feature by “turning on” this feature. If the CO<sub>2</sub> monitor is not exposed to constant high levels of CO<sub>2</sub>, the sensor will automatically adjust the baseline setting and there is no further action required by the user. The sensor is factory calibrated and requires no user calibration.

**NOTE: DO NOT use the auto calibration feature if you are monitoring continuous levels of CO<sub>2</sub> for control of grow rooms. The monitor needs to be in ambient lower levels for the autocal feature to operate properly.**

To access the Auto Calibration mode, go to the Sensor Adjustment main menu.

..Sensor Adjustment..

Press the joystick right to access the **Set CO<sub>2</sub> sensor span** sub menu.

..Set CO<sub>2</sub> sensor span..

Push the joystick down to access the **Turn CO<sub>2</sub> autocal on** menu. The display will scroll the following:

..Turn CO<sub>2</sub> autocal on..

To turn ON this feature push the joystick right. The display will scroll the following:

..Press ENTER to continue..

Push the joystick in, (like a doorbell) to activate the autocal feature. The audio horn and CO<sub>2</sub> alarm horn will activate momentarily. Every week the CO<sub>2</sub> sensor will automatically adjust back to 400PPM which is the ambient level on earth.

***NOTE: DO NOT use the auto calibration feature if you are monitoring continuous levels of CO<sub>2</sub> for control of grow rooms. The monitor needs to be in ambient levels for the autocal feature to operate properly.***

You can also disable or “turn off” the auto calibration feature. If the CO<sub>2</sub> monitor is exposed to constant high levels of CO<sub>2</sub>, the user **MUST** inhibit, “turn off” the autocal feature and perform a manual baseline adjustment approximately every six months or more often if desired. To turn OFF the auto calibration feature, push the joystick down to access the menu.

The display will scroll the following:

..Turn CO<sub>2</sub> autocal off..

To turn OFF this feature push the joystick right. The display will scroll the following:

A light blue rounded rectangular box with a thin black border, containing the text "..Press ENTER to continue..".

Push the joystick in, (like a doorbell) to activate the autocal feature. Push the joystick in, (like a doorbell) to activate the autocal feature. The CO<sub>2</sub> alarm horn will activate momentarily. The auto calibration feature has now been disabled. You can now **manually** calibrate the CO<sub>2</sub> sensor to ambient 400 PPM one demand. *Refer to section 6.3, Sensor calibration CO<sub>2</sub>.*

### 5.5.10 Main Operation Mode

To select the main menu from any sub menu, push the joystick left until the Main Menu appears. The digital display will indicate the following:

A light blue rounded rectangular box with a thin black border, containing the text "CO<sub>2</sub> 400PPM".

## 6: Maintenance & Sensor Verification

---

*Only qualified personnel should perform maintenance and sensor verification*

### 6.1 Sensor Calibration, CO<sub>2</sub>

---

PureAire incorporates the use of an NDIR (Non Dispersive InfraRed) CO<sub>2</sub> sensor in the CO<sub>2</sub> Monitor. The sensor is factory calibrated and will always provide an accurate reading that is the difference between a baseline setting and the actual CO<sub>2</sub> measurement. As typical with most NDIR sensors, long term drift can affect the baseline setting. To compensate for this drift, an automatic background calibration function is built into the sensor and is enabled by default from the factory. This calibration feature assumes that during a 24 hour period, the monitored CO<sub>2</sub> levels return to normal ambient conditions, such as in an office environment or spaces that are unoccupied during the evening.

**If the monitor is constantly exposed to elevated levels of CO<sub>2</sub>, for example, in an agricultural growing room, the auto calibration feature should be inhibited, “turned off” and a manual calibration performed approximately every six months. See Section 5.5.11 to turn off the autocal feature.**

**CAUTION: DO NOT ADJUST the CO<sub>2</sub> sensor unless you are certain that the CO<sub>2</sub> level has returned to normal ambient conditions, such as in an outdoor environment or spaces that are unoccupied. If using calibrated CO<sub>2</sub> span gas, ensure that the gas is not being diluted with room air.**

To perform a manual adjustment of the CO<sub>2</sub> sensor to ambient 400PPM, use the following procedure. Use the joystick to enter the password, then push the joystick to the right and navigate to the “Sensor Adjustment” menu. The display will scroll

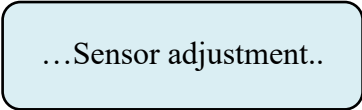

...Sensor adjustment..

Push the joystick right once and the display will scroll:

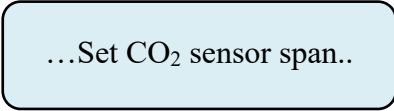

...Set CO<sub>2</sub> sensor span..

Push the joystick right once to display:

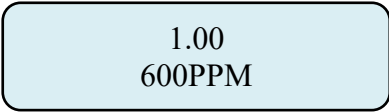

1.00  
600PPM

To adjust the baseline setting, expose the monitor to ambient air, either outside or in a well-ventilated room for about 5 minutes. **OR** expose the sensor to a span gas cylinder with a certified concentration of CO<sub>2</sub>. Push the joystick up to increase the CO<sub>2</sub> reading, or push the joystick down to decrease the CO<sub>2</sub> reading displayed on the second line of the digital display.

When done setting the calibration, push the joystick left once and the display will scroll:

...Set CO<sub>2</sub> sensor span..

### 6.1.2 Adjusting the CO<sub>2</sub> sensor manually to an exact 400PPM value

There is a provision in the software for a user to manually adjust the reading of CO<sub>2</sub> monitor to an exact 400ppm value. **DO NOT ADJUST the CO<sub>2</sub> sensor unless you are certain that the CO<sub>2</sub> level has returned to normal ambient conditions, such as in an outdoor environment or spaces that are unoccupied. Be careful to not breath near the sensor because a person can exhale very high concentrations, ( 30,000PPM ) of CO<sub>2</sub>**

To perform a manual adjustment of the CO<sub>2</sub> sensor to an exact 400PPM, use the following procedure. Use the joystick to enter the password, then push the joystick to the right and navigate to the “Sensor Adjustment” menu. The display will scroll:

...Sensor adjustment..

Push the joystick right once and the display will scroll:

...Set CO<sub>2</sub> sensor span..

Push the joystick down once to display:

..Calibrate CO<sub>2</sub> sensor to 400 PPM...

Push the joystick right once to display:

..Press ENTER to continue..

Push the joystick in, (like a doorbell) to set the reading to 400PPM. You have now reset the CO<sub>2</sub> sensor to 400PPM. To exit the calibration menu, push the joystick left four times to display the monitoring mode.

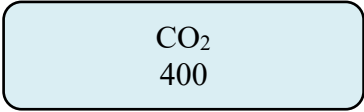

# 7.0 Appendix

## CONTACTOR/FAN CONNECTION

EXTERNAL RELAY FOR LOADS >2A

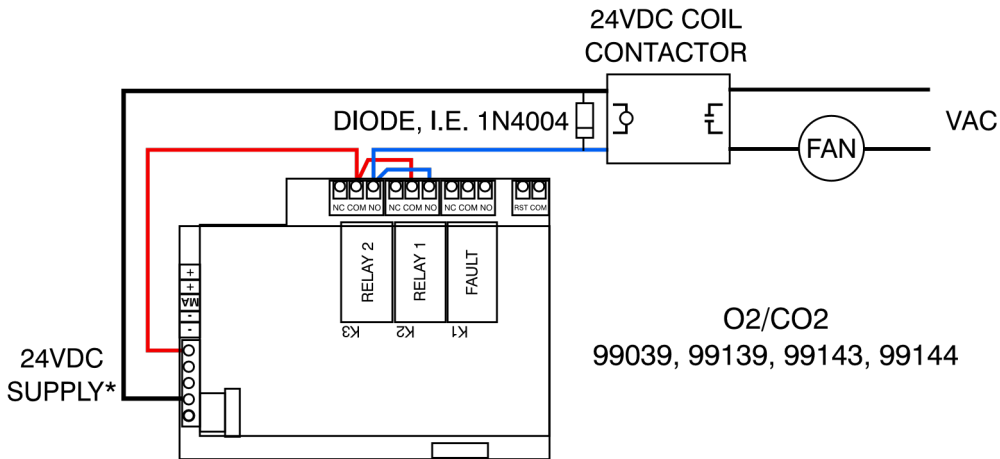
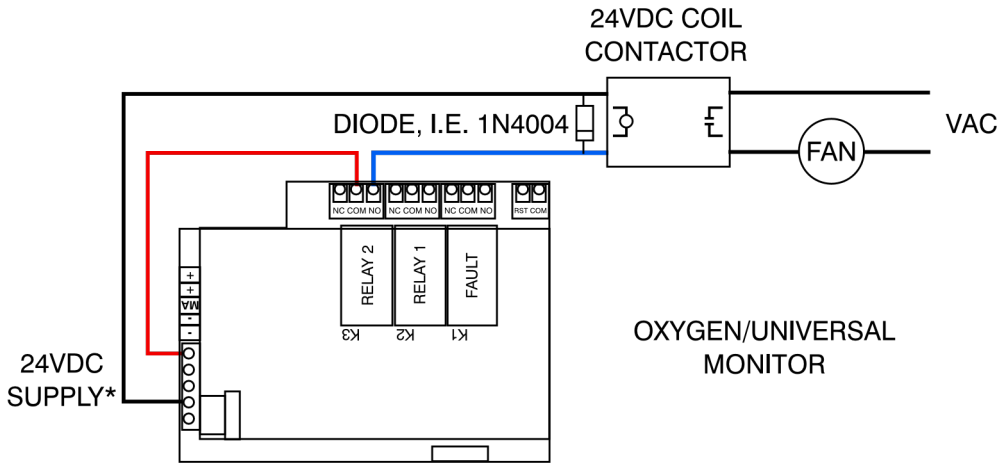

DIAGRAMS FOR 99016, 99029, 99129, 99028, 99145, 99097, 99141, 99035, 99128, 99020, 99045, UNLESS NOTED.

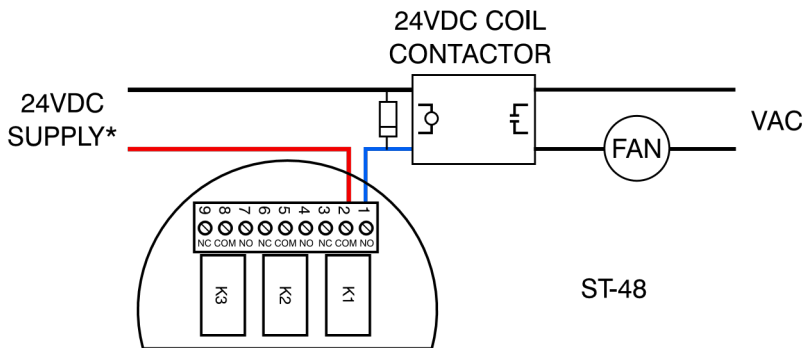

**NOTE:** ENSURE CONTACTOR CHOSEN HAS CORRECT COIL VOLTAGE AND IS CURRENT-RATED FOR YOUR LOAD

\* OK TO USE EXTERNAL SUPPLY AS LONG AS VOLTAGE IS 24VDC/AC OR LESS

### How to convert 4-20mA current output to a 1-5 VDC voltage output

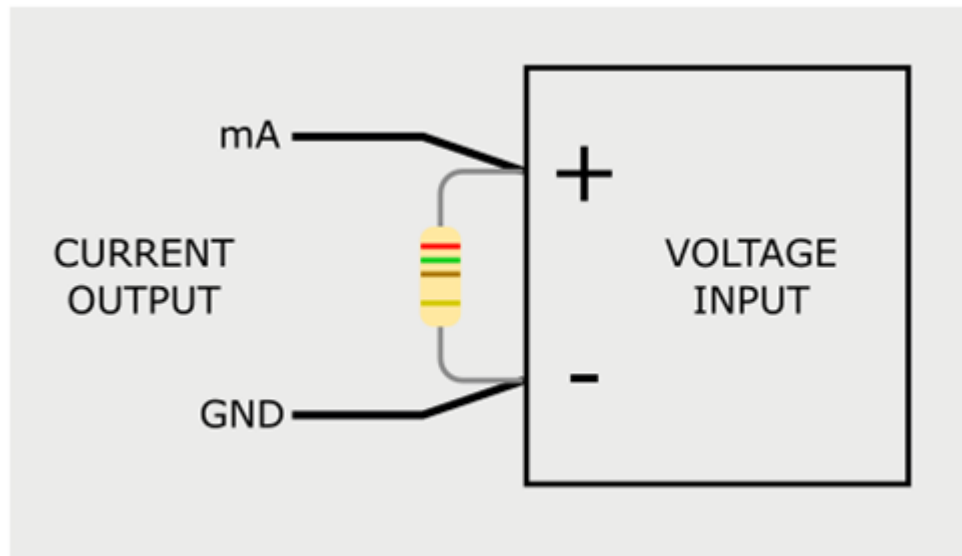
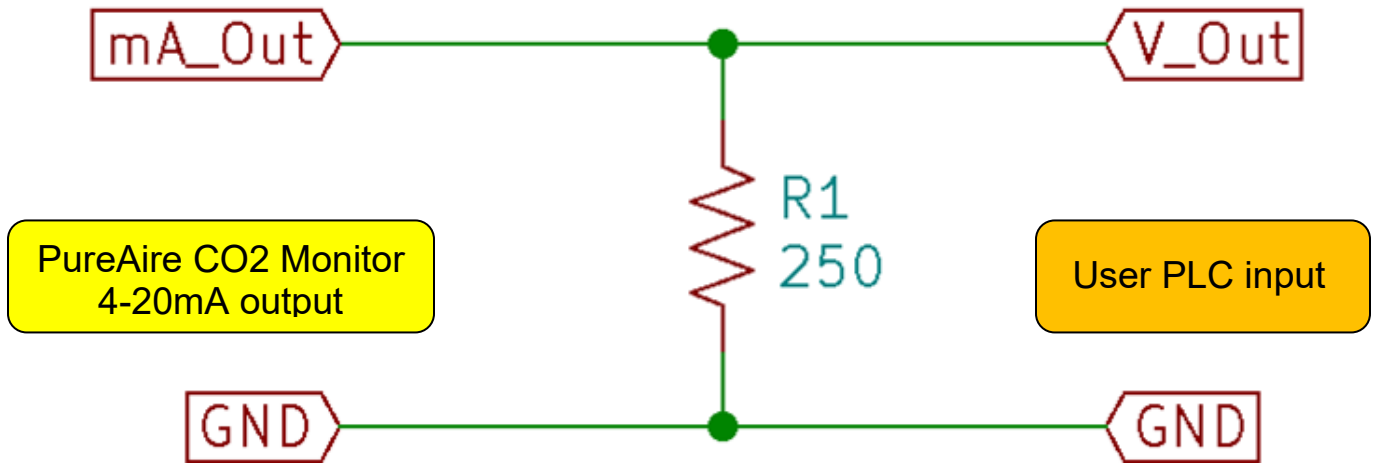

Attach 250-ohm resistor to the PLC or device input