



PureAire Dual Oxygen & Carbon Dioxide Monitor

Instruction Manual

Part Number 99188, 99230

Oxygen Range 0-25%

Carbon Dioxide Range 0-50,000ppm



PureAire Monitoring Systems, Inc.

1140 Ensell Road

Lake Zurich, Illinois 60047

Phone: 847-726-6000

Toll-Free: 888-788-8050

pureairemonitoring.com

Rev. 1.12 May 15, 2026

Welcome to PureAire Monitoring Systems

I would like to thank you for investing in our continuous life safety and process control toxic gas monitoring systems.

PureAire offers an unbeatable combination of experience and innovation in solving the safety and environmental needs of our customers. We can provide small systems of a few points to a total multi-point turnkey computerized package.

PureAire's proprietary sensor cell technology and state-of-the-art electronics are designed to interface with the latest distributive or PLC-based control systems. We believe that our experience, innovative products, and commitment to service will satisfy your specific monitoring needs now and in the future.

Our growth is a result of our total commitment to supporting our customers. We are available 24 hours a day, 7 days a week to help you when you need us. Our 24-hour Emergency phone number is 1-224-443-5445. We can provide field service, preventative maintenance programs, and training to your technicians in the operation of our equipment. Our goal is to provide the best after-sale service and support in the industry. That is just one way PureAire takes that extra step to ensure your complete satisfaction.

Thank you again for investing in PureAire Monitoring Systems for your monitoring needs and I am proud to welcome you to our family of valued and satisfied customers.

Sincerely,

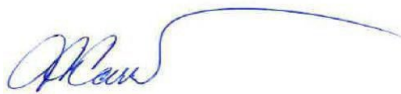
A handwritten signature in blue ink, appearing to read 'A. Carrino', with a long, sweeping flourish extending to the right.

**Albert A. Carrino
CEO**

Please Read Before Installation

The following will damage the Oxygen/Carbon Dioxide Monitors.

1. The Oxygen and Carbon Dioxide Monitors require **24 VDC regulated power**. **Please Do Not connect** the monitors to any voltage that exceeds 24 Volts DC, or **ANY AC Voltage**.
2. Do not power the **Monitor** with the **oxygen** or **CO₂ sensor** unplugged from the main PC board. **Do Not Connect** the **sensors** to the PC board while the monitor is powered. This Will Damage the **sensors**.
3. The **oxygen** and **CO₂ sensor cells** are matched to the electronics. **Never exchange** the electronics with an oxygen sensor or carbon dioxide sensor from a different monitor.
4. When calibrating or challenging the **O₂** or **CO₂ Monitors**-
 - a. Do not expose the monitors to flow rates that exceed ½ liter per minute, (500 cc per minute) flow.
 - b. Expose the monitor to span gas blends that consist of Oxygen, Nitrogen, or Carbon Dioxide only. **Do not expose the monitor to any combustible gas**, i.e., Methane, Hydrogen, etc. Exposure to combustible span gases can damage the sensors.
5. Do not expose the **Monitor** to silicone, Freon, or corrosive compounds. They can cause a loss of sensitivity and damage the sensor.
6. When using the **Water Resistant O₂/CO₂** monitor in wash-down areas, make sure to orient the filter with the drain opposite the water flow. (see section 2.4)
7. **The Factory Password for entering the menus is 557**

Table of Contents

1: Introduction	1
1.1 Key Features	2
1.1.1. Long Lasting Zirconium Oxide O ₂ Sensor.....	2
1.1.2. NDIR CO ₂ IR Sensor	2
1.1.3. Smart Electronics	2
1.1.4. Calibration	2
1.2 Electrical Requirements.....	2
1.3 Physical Characteristics	2
2: Installation	3
2.1 Site Requirements	3
2.2 Mounting.....	3
2.3 Component identification	4
231. Front View Exterior with Relays	5
232. Monitor Interior	6
233. Alarm Relay Board	6
2.4 Sample Inlet Filter	7
3: Oxygen Monitor Specifications	9
3.1. Performance Specifications.....	9
3.2. Gas Detection System.....	9
3.3. Signal Outputs	9
3.4. Oxygen Monitor System Default Factory Settings	10
3.5. Wiring.....	11
3.6. Initial Startup	13
3.7. Normal Operation	14
3.7.1. Signal Outputs	14
3.7.2. Instrument Faults	14
3.7.3. Routine Maintenance Schedule	15
373.1. Recommended Maintenance Schedule	15
3.7.4. Loss of Power Indicator	15
3.7.5. Alarm Reset	15
3.8. PureAire Oxygen Monitor Programming	16
3.8.1. Joystick Operation	16
3.8.2. Program Flowchart	17
3.8.3. Entering the Password	21
3831. Changing User Password.....	22
3832. Enable User Password.....	24
3833. Rest User Password	24
3.9. Entering the Menus	25
3.9.1. Set 4-20mA Loop	25
3.9.2. Set Formats	27
3.9.3. Set Alarm Threshold Polarity	29
3.9.4. Set Latching.....	31
3.9.5. Resetting a Latching Alarm	34
3.9.6. Set Alarm Delay	34
3.9.7. Set Zero Suppression	35
3.9.8. Set Alarm Thresholds	35
3.9.9. Set Alarm Hysteresis	37
3.9.10. Set Sensor Adjust.....	38

3.9.11. Main Operation Mode.....	39
3.10. Maintenance & Cell Verification	40
3.10.1. Sensor Verification.....	40
3.10.1.1. Sensor Verification Gas	40
3.10.1.2. Sensor Verification Equipment.....	40
3.10.2. Sensor Verification Procedure.....	41
3.10.2.1. Sensor Verification to Nitrogen	42
3.10.2.2. Sensor Verification to Oxygen.....	42
4: Carbon Dioxide Monitor Specifications	44
4.1 Performance Specifications	44
4.2 Gas Detection System.....	44
4.3 Signal Outputs	44
4.4 System Default Factory Settings	45
4.5 Wiring	45
4.6 Initial Startup	47
4.7 Normal Operation.....	48
4.7.1. Signal Outputs	48
4.7.2. Instrument Faults	48
4.8. Routine Maintenance Schedule	48
4.8.1. Recommended Routine Maintenance Schedule	49
4.8.2. Loss of Power Indicator	49
4.8.3. Alarm Reset.....	49
4.9. Carbon Dioxide Monitor Programming.....	50
4.9.1. Joystick Operation.....	50
4.9.2. Program Flowchart.....	51
4.9.3. Entering the Password	55
4931. Changing the User Password	56
4932. Enable User Password.....	58
4933. Reset User Password.....	58
4.10. Entering the Menus.....	59
4.10.1. Set 4-20mA Loop.....	59
4.10.2. Set Formats.....	60
4.10.3. Set Alarm Threshold Polarity.....	63
4.10.4. Set Latching.....	64
4.10.5. Resetting Latching Alarm.....	66
4.10.6. Set Alarm Delay.....	66
4.10.7. Set Zero Suppression.....	67
4.10.8. Set Alarm Thresholds.....	67
4.10.9. Set Alarm Hysteresis.....	69
4.10.10. Auto Calibrate.....	70
4.10.11. Main Operation Mode	72
4.11. Maintenance & Cell Verification	73
4.11.1. Sensor Calibration CO ₂	73
4.11.2. Adjusting the CO ₂ Sensor Manually	74
5: Appendix.....	76

1:Introduction

The **Dual Oxygen/Carbon Dioxide Monitor** is a self-contained gas monitoring system that is ideal for the continuous monitoring of inert gases in storage areas, confined spaces, and other locations where low oxygen levels and/or elevated carbon dioxide levels may pose a hazard to personnel. Unlike electrochemical sensor cells, the zirconium oxygen sensor cell and patented NDIR carbon dioxide cell provide stable readings even in areas where temperature and humidity levels are changing. **PureAire's Dual O₂/CO₂ Monitor** is suitable for either indoor or outdoor use. Factory calibrated against a NIST traceable reference standard and UL, CUL and CE approved.

PureAire's Dual O₂/CO₂ Monitor combines our Oxygen Deficiency Monitor with our Carbon Dioxide Monitor housed in a dust and watertight NEMA 4X/IP67 enclosure. The Dual Monitor includes two 4-20ma output signals with dedicated circuits, signal outputs for both O₂ and CO₂, two relays, as well as two alarm set points for both oxygen and carbon dioxide monitors.

PureAire's Oxygen Deficiency Monitor is built with a long-lasting zirconium oxygen sensor, which responds to low oxygen conditions within seconds and provides accurate measurements over a wide temperature and humidity range. The Monitor will operate continuously for 10+ years with no time-consuming, scheduled maintenance. The Monitor does not drift or lose sensitivity due to weather or temperature changes.

PureAire's Carbon Dioxide Monitor is built with a non-dispersive infrared sensor (NDIR) cell, which responds to high carbon dioxide conditions within seconds and provides accurate measurements over a wide temperature and humidity range. The NDIR CO₂ sensor cell will operate continuously for many years and requires an absolute minimum of maintenance. There are no zero or span calibration pots to adjust and its built-in auto-calibration can save time and money in annual maintenance.

The **Dual O₂/CO₂ Monitor** may be used as a stand-alone gas detector, linked to optional PureAire single and multipoint controllers, or connected to a centralized control and surveillance system.

This manual covers the installation, operation, and maintenance of **PureAire's Dual O₂/CO₂ Monitor**.

NOTE: *For our continual product improvement, all specifications are subject to change without notice.*

1.1. Key Features

The Dual O₂/CO₂ Monitor incorporates several user-friendly features designed to simplify installation, operation, and maintenance.

1.1.1. Long Life Zirconium Oxide O₂ Sensor

The system's O₂ sensor cell has a life of well over 10 years of continuous operation. Unlike concentration O₂ cells, PureAire's exclusive zirconium oxide sensor cell does not need an oxygen reference gas for proper operation. The O₂ monitor can detect low oxygen levels in confined spaces and process tools without the need for a reference gas.

1.1.2. NDIR CO₂ IR Sensor

The monitor's CO₂ sensor cell is a patented Non-Dispersive Infrared (NDIR) cell designed to detect continuous levels of CO₂. The cell responds quickly and has a built-in auto-calibration feature that adjusts the sensor to ambient every 180 hours.

1.1.3. Smart Electronics

The Dual O₂/CO₂ Monitor incorporates a special electronic circuit that continuously monitors sensor operation. Any cell degradation or complete failure will immediately be detected. This smart circuitry alerts the user to sensor faults and other electrical problems that may interrupt surveillance through the standard mA signal output signal or through the fault relay option.

1.1.4. Calibration O₂

The **Oxygen Monitor** incorporates a stable zirconium oxide sensor that rarely requires adjustment. Changing barometric pressure changes or changes in temperature and humidity do not affect the zirconium oxide oxygen cell. The earth is a wonderful source of calibrated oxygen at 20.9%, therefore under ambient conditions, visual verification of the PureAire O₂ monitor to 20.9% oxygen is easily performed. There are no zero or span pots to adjust. The O₂ monitor only requires periodic testing with nitrogen to verify the cell's response to low oxygen levels. See Section 3.10.2.1. for the testing procedure using nitrogen.

1.1.5. Calibration CO₂

The **Carbon Dioxide Monitor** incorporates an NDIR CO₂ sensor that provides an accurate reading that is the difference between a reference baseline setting and the measured gas concentration. The sensor is factory calibrated and requires no user calibration but as typical with most NDIR sensors, long-term drift can affect the baseline setting. Under normal conditions, the sensor provides automatic baseline adjustments, and no further action is required by the user. However, under certain conditions, manual adjustments may be required. See Section 4.10. for further explanation and procedures for adjusting the baseline setting.

1.2. Electrical Requirements

Power: 24 VDC external power. A regulated 24VDC power supply is required. Consumption: Approximately 300mA

1.3. Physical Characteristics

Enclosure Type: NEMA 4X/IP67 - Not intended for explosive atmospheres.
Weight: 5.0 pounds (2.27 kg)

2: Installation

2.1. Site Requirements

The PureAire O₂/CO₂ Monitor should be mounted in an area free of vibration and electrical noise or interference. If possible, avoid areas with high temperatures or condensing humidity.

The monitor covers an area of approximately 692 square feet when mounted on a wall and should be placed no more than 21 feet from potential leak sources such as gas lines, gas cylinders, or any areas where a gas leak might be expected to occur.

To ensure safety, the maximum distance between two monitors mounted to the same wall, should not exceed 30 feet.



WARNING

The PureAire O₂/CO₂ monitor is not designed for installation in hazardous areas. Consult PureAire for information on enclosures for use in hazardous environments.

2.2. Mounting

Enclosure

The PureAire monitor is designed primarily for wall mounting and should be installed at a height convenient for operation, maintenance, and viewing of the instrument display. The following is a drawing of the mounting dimensions.

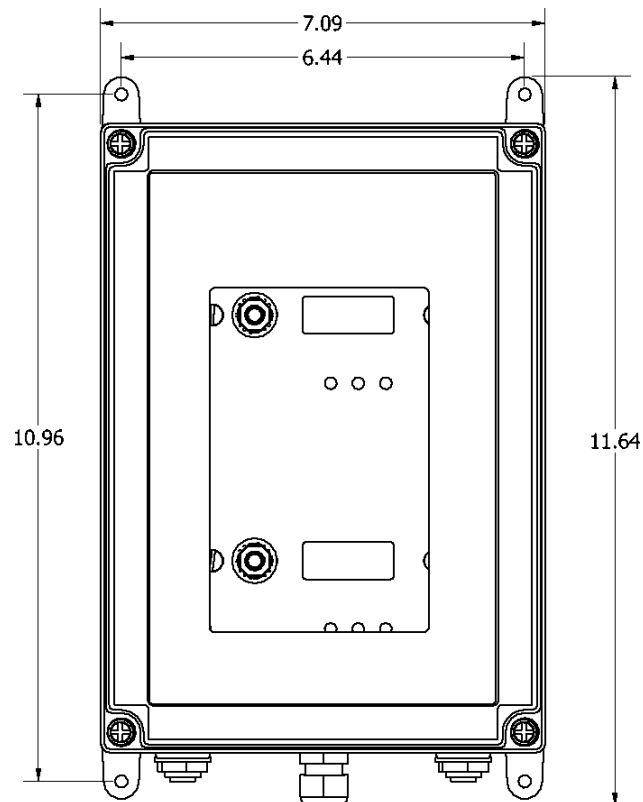

The monitor should be installed in a location where gas leaks are likely to occur or where released gases may accumulate. It should be mounted no closer than 12 inches above floor level. **Airflow within the monitored area, the characteristics of the gas (lighter or heavier than air), and the**

position of workstations and personnel should all be considered in determining the most suitable installation location.

2.3. Component Identification

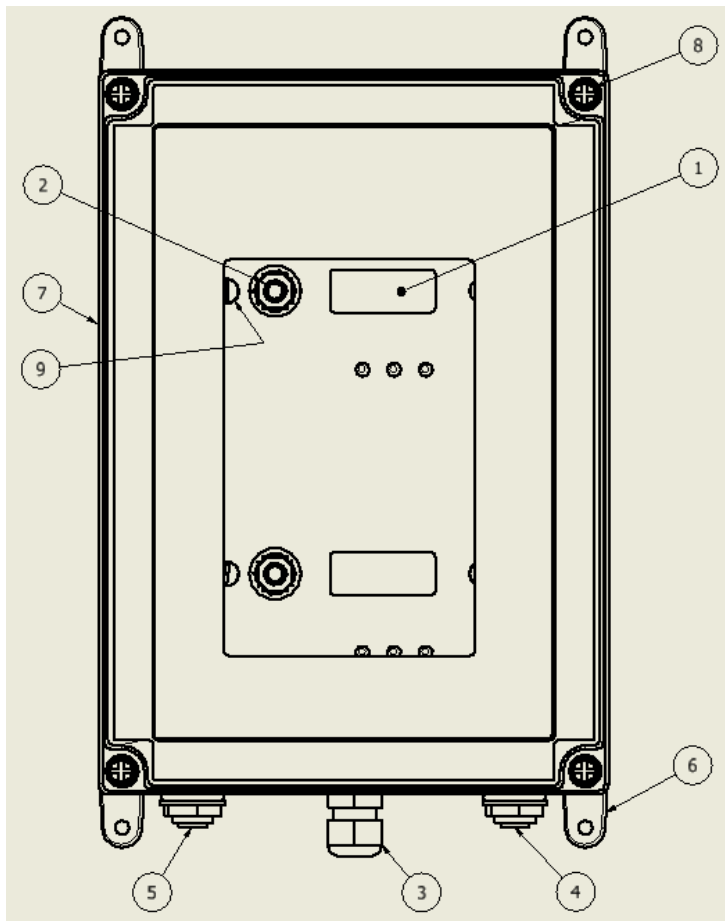

- 1. Digital Display** — Backlit display for showing the oxygen levels in percent.
- 2. Joystick** — Used for selecting and adjusting the built-in menus. The PureAire O₂ monitor is available with optional dual-level user selectable relays. The joystick is also used to select alarm levels, relay settings, and reset any latching visual and audio alarms.
- 3. Cable Port** — This is the opening in the monitor housing for connecting the 24 VDC power cable and 4-20 mA output.
- 4. Sample Inlet** —
- 5. Sample Exhaust** —
- 6. Mounting Feet** — There are 4 feet used to mount the oxygen monitor to a wall or other flat surface. Mounting Feet Can be oriented in any direction and can also be removed for mounting the monitor flush with a wall or other surface
- 7. Monitor Cover** — A removable cover that protects the interior of the monitor.
- 8. Monitor Cover Fasteners** — There are 4 captive screws to secure the monitor cover in place.
- 9. Electronics Fasteners** — These captive screws secure the electronics to the enclosure.

2.3.1. Front View Exterior with Relays

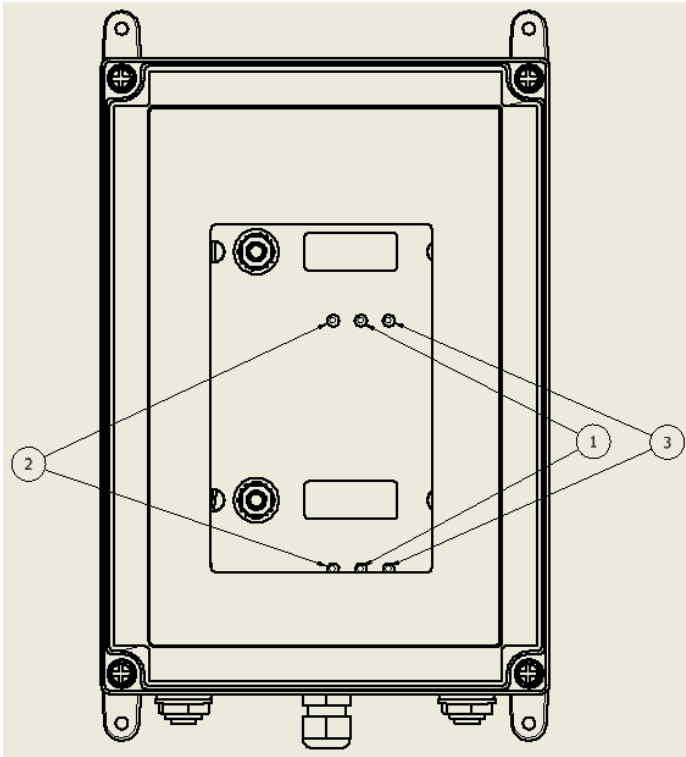

Alarm Indicators — Three LED indicators for showing:

1. Alarm level 1 OrangeLED
2. Alarm level 2 RedLED
3. Fault Alarm Yellow LED

2.3.2. Monitor Interior

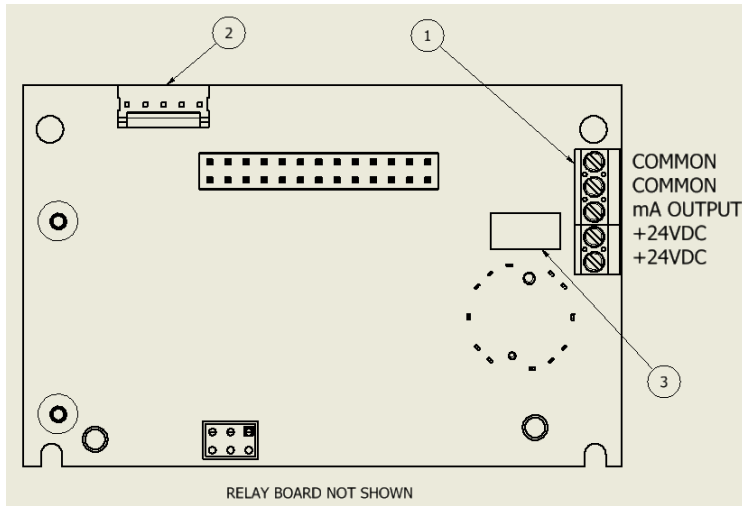

1. **Power Analog Terminal Block** — This terminal block is where the 24VDC power and 4-20 mA analog output connection is made.

2. **Oxygen Sensor Connector** — This connector is where the Oxygen sensor cell is connected. **NOTE: Never connect the sensor to this connector while the monitor is powered. This will damage the sensor**

3. **PTC Resettable Fuse** — The PCB is protected with a PTC Fuse that is resettable and never needs to be replaced. If it trips, you will need to turn the power off to the monitor. When power resumes the fuse will reset.

2.3.3. Alarm Relay Board

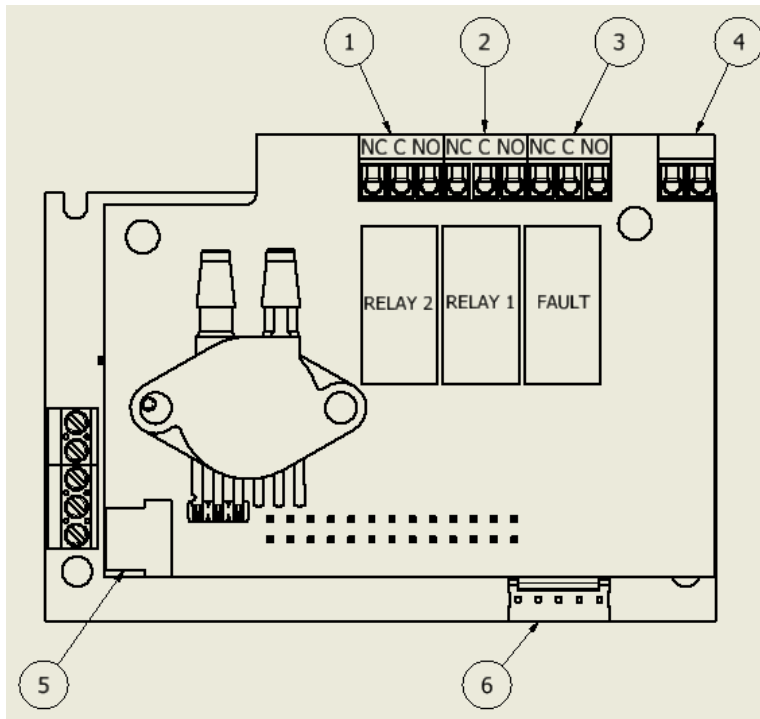

1. Relay 2
2. Relay 1
3. Fault Relay
4. Remote Reset
5. Pump Connector
6. Oxygen Sensor Connector

2.4. Sample Inlet Filter

To protect the pump from water, a special filter is supplied with the monitor. On installation, attach the water filter to the sample inlet by pushing the filter into the ¼" tube compression fitting. Aligning the arrow, (printed on the filter) towards the monitor. The filter pulls air from both vertical and horizontal tubes. **Never connect any sampling tubing to either tubing port.** When sampling remote, **ALWAYS** locate this filter at the end of the sample line.

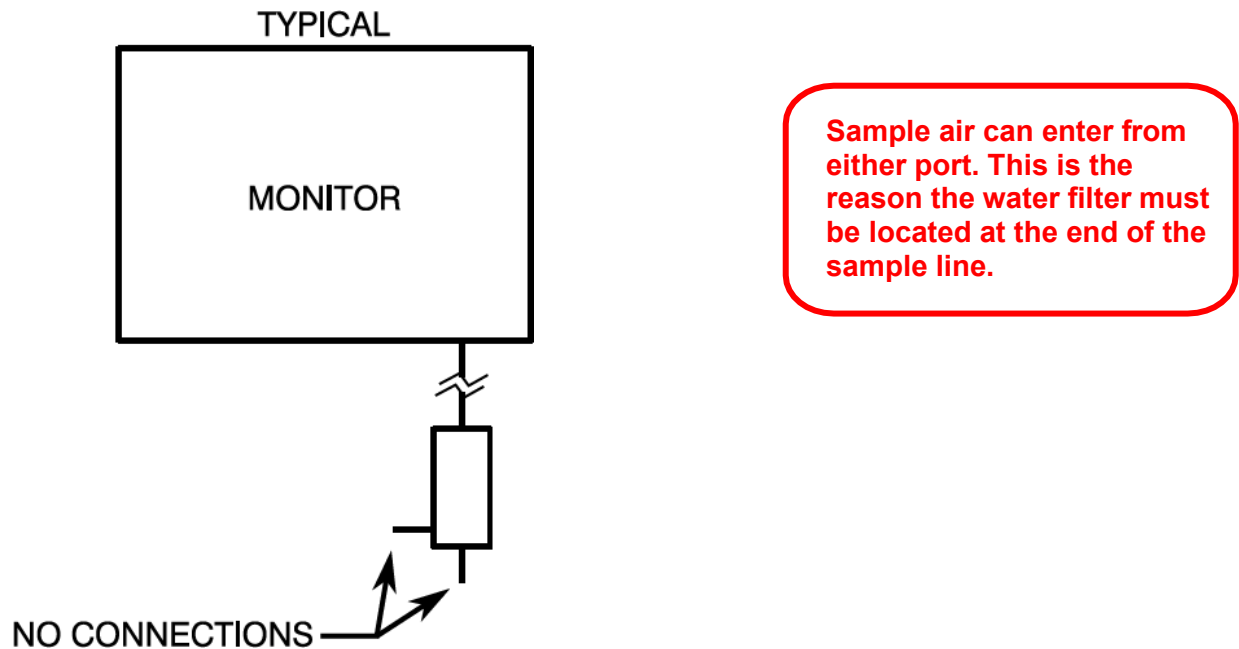

The PureAire O₂/CO₂ Monitor has an internal sample pump flow rate that is programmed at the factory and cannot be changed in the field. A flow sensor on the relay board continually monitors flow rate. When a loss of flow is detected, a signal is sent to the fault relay and the front mounted LED will activate. Sample flow to the monitor is continuously monitored and controlled by the flow control microprocessor.

NOTE: If using longer lengths of sample tubing, the water filter must be located at the end of the sample line to work properly.

NOTE: If the sample line is blocked, the fault indicator will illuminate, and the pump will accelerate to try and reestablish the proper flow rate. If the line is cleared, the pump will speed and slow down and the fault light will turn off when the flow rate is back to factory setting.

Depending on the environment, replacement of this filter should be performed every 12 months. In dusty environments, a **standard filter (p/n 23102)** should be added at the monitor. If the filter becomes completely blocked, the internal flow sensor will detect the loss of flow and activate the fault relay and LED. **Order water filter part number 90179**

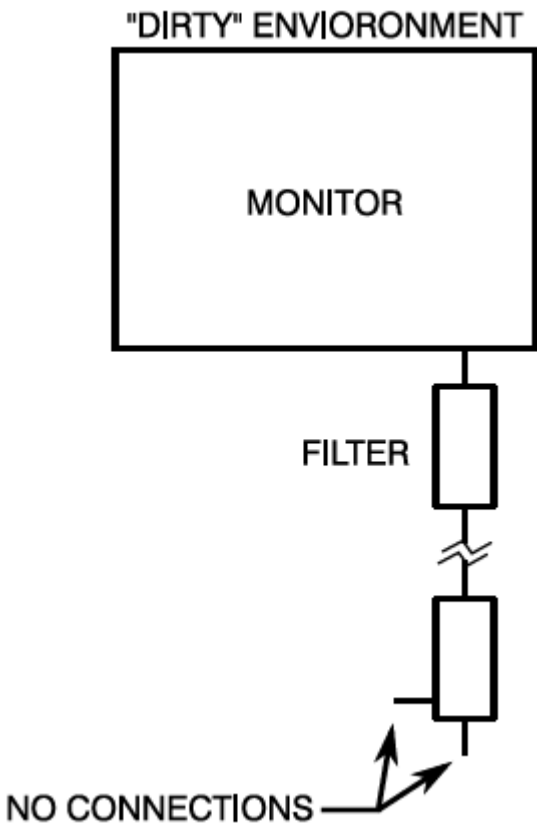

Photo shown is a waterproof monitor located at the risk site.

If any length of sample tube is needed to sample remote, the water filter must be located at the end of the sample tubing.

1/4" tube push to connect fitting **

Water Sample filter p/n 90179

Sample air can enter from either port. This is the reason the water filter must be located at the end of the sample line.

****NOTE:** PureAire recommends the use of polypropylene sample tubing with the dimensions of 1/4 OD by 3/16" ID. The total length tubing should not exceed 100 feet

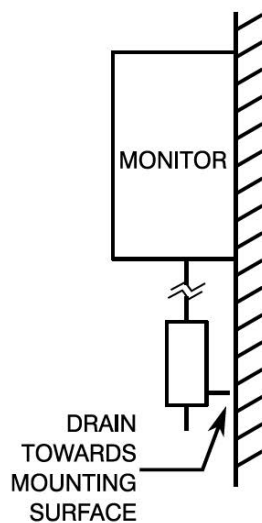

NOTE: When used in wash down areas, the water filter drain must be oriented opposite the water flow. (i.e., orient the drain towards the back of the monitor to prevent water from building up inside the drain.)

3: Oxygen Monitor Specifications

NOTE: For our continual product improvement, all specifications are subject to change without notice.

3.1. Performance Specifications

Sensor Type:	Long Life Zirconium Oxide Sensor Cell 0-25%
Response Time:	Within 1 second of any change in O ₂ .
Accuracy:	Delivers $\pm 0.2\%$ O ₂ accuracy ($\pm 1\%$ of full range)
Fault Indicators:	Loss of VDC power (analog signal drops to 0 mA). Sensor cell failure: Fault relay activated.
Operating Temp:	41° to 122°F (5° to +50°C); consult PureAire for lower or higher operating temperatures.
Humidity:	0 to 95% RH; consult PureAire for sensors that can operate in 100% condensing RH environments.
Environment:	PSU only UL spec , Altitude 2000 m, Pollution Degree 3, Intended for Indoor Use.
UL / CUL listing:	Measuring Equipment E363306
Ce	EN 61000-3-2:2006 EMC, EN 61000-3-3:2008 EMC, EN61010-1-3-2013 LVD

3.2. Gas Detection System

Type:	Long Life Zirconium Oxide Sensor Cell, Range 0-25%
Sensor Life:	8 to 10+ years under normal conditions.
Transmitter:	Microprocessor electronics with built-in 3-digit backlit LCD display Joystick-operated menus

3.3. Signal Outputs

Standard	Analog Output: DC 4-20 mA Relay Output: Dual level user selectable alarm relays and one fault relay Rated, 2amps @ $\leq 24\text{VAC}$ or 24VDC
----------	--

3.4. Oxygen Monitor Default Factory Settings

The PureAire O₂ Deficiency Monitor is shipped with factory defaults for the alarm relay settings. The following are the factory defaults:

Menu Function	Factory Default	Menu Defined
Set 4-20mA loop	The mA output is set at the factory using a calibrated Fluke meter.	Use this function to adjust the Oxygen monitors 4mA, (Zero) and 20mA, (Span) to your PLC or distributive control system.
Set Formats LED and alarm relay State **	Alarm 1 = Normal Alarm 2 = Normal Fault = Normal	Do you want the relays to energize, (normal) or de-energize, (fail safe) when the alarm activates?
Set Alarm Threshold Polarity	Alarm 1 = Inverted Alarm 2 = Inverted Audio = Inverted*	Do you want to alarm at a level higher, (normal) or lower, (inverted) than the alarm threshold?
Set Latching	Alarm 1 = Non-latching Alarm 2 = Non-latching Audio = Non-latching	Do you want the alarm to automatically reset? (non-latching) or do you want to manually reset the alarm? (latching)
Alarm Delay	Alarm = 5 seconds	How long do you want to wait until the alarms activate?
Zero Suppression	000 = 0.00% Refer to section 3.9.7.	This function is Not Enabled on the Oxygen monitor.
Set Alarm Thresholds	Alarm 1 = 19.5 % Alarm 2 = 18.0 % Audio = 19.5%*	At what level do you want to alarm?
Set Alarm Hysteresis	Alarm 1 = 0.0 % Alarm 2 = 0.0 % Audio = 0.0 %	For use when using the O ₂ monitor for control of valves and processes. See Section 3.9.9.
Sensor Adjustment	No factory default	For use when dynamically gas calibrating the Oxygen monitor to a known span gas. See Section 3.9.10.
Manage Passwords	Factory default is 557	For use when changing the password from factory default to a new password of your choice.

NOTE: The built-in relay settings may be changed by the user in the field. Refer to Section 3.9.2.

* **NOTE:** The Audio alarm feature is optional.

** **NOTE:** The LED indicators on the front panel are connected directly to the alarm relays.

3.5. Wiring

PureAire monitors require a 3-wire shielded cable for analog output and 24 VDC power input. A three-wire shielded cable; 3-conductor, 18 AWG-stranded General Cable E2203S.30.860, or equivalent is recommended for the connection. The analog out and VDC power in connections are made on the terminal block inside the monitor housing.



CAUTION: To avoid damaging the monitor, please rotate the front inside panel to the left when making relay connections. (See figure A)

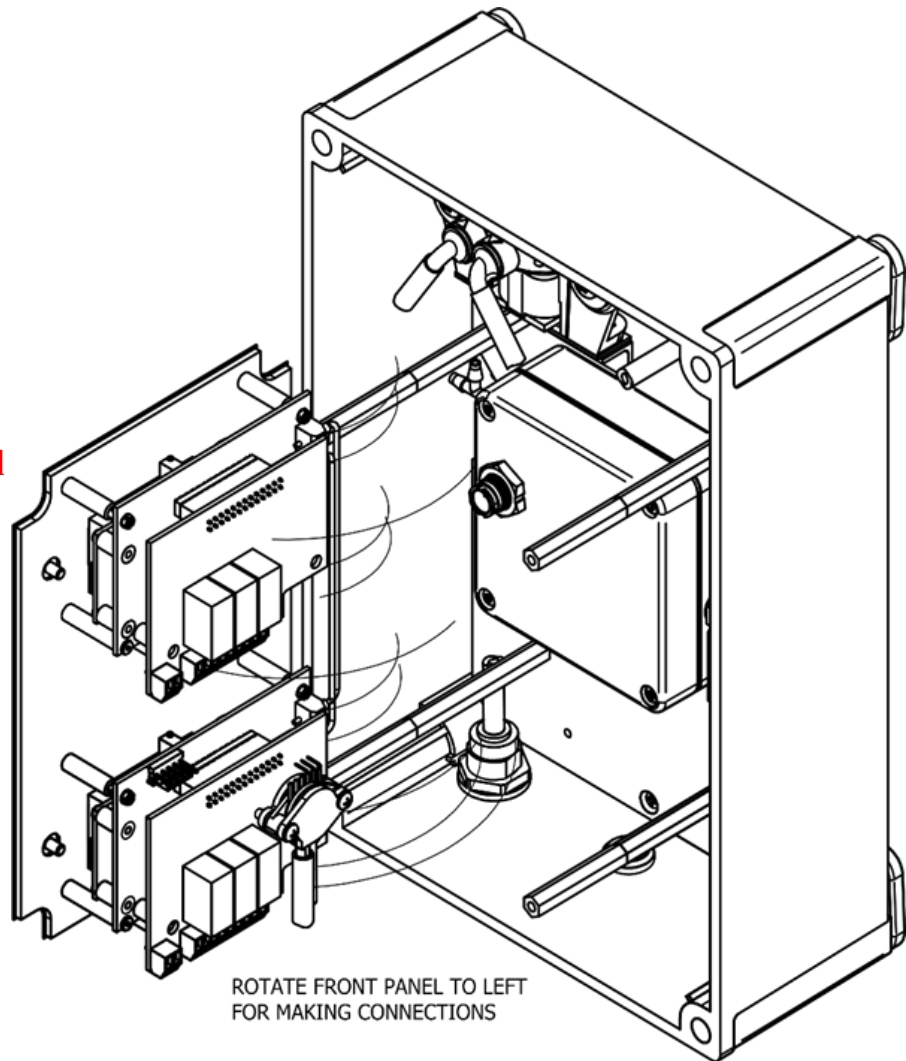
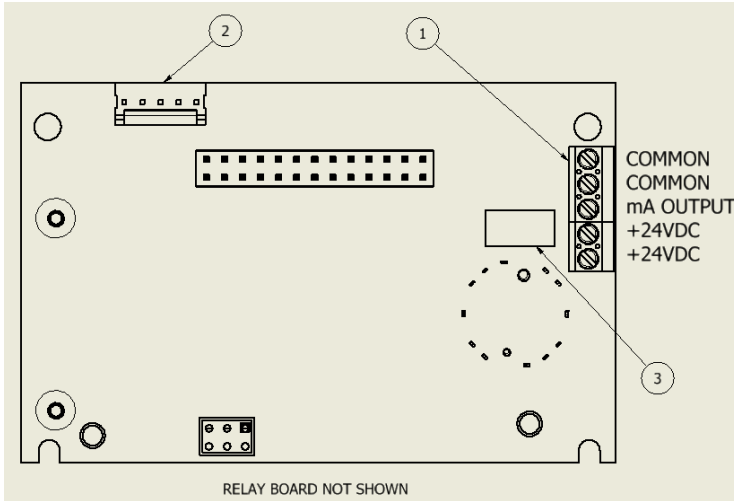

Figure A

These connections are made as follows:



PureAire provides the plug-in power supply



Caution

DO NOT connect to an active/powered current-loop receiver. The PureAire Oxygen monitor supplies the current loop power.

Pin #	Connection	Description
-	Common (Signal Ground)	0V
-	Common (Signal Ground)	0V
MA	Signal Out	DC 4-20mA Output
+	Power	DC + 24V Input
+	Power	DC + 24V Input

NOTE: *PureAire has added additional contacts for +24VDC power and Common to accommodate additional wiring for remote horns and strobes*

3.6. Initial Startup

Once the installation of the gas detector has been completed, it is ready for startup. The following procedures should be performed before putting the instrument into operation:

Check the integrity of all wiring.
Apply 24 VDC power.

The instrument should now be powered up. Upon power up, the PureAire O₂ Monitor LCD displays the PureAire logo and then starts a 4-minute, (240 seconds) count down as the current to the zirconium oxide O₂ sensor stabilizes. The monitor will output a 4 mA signal during the entire warm-up period. After the countdown, the oxygen sensor will continue to reach its operating temperature for approximately 30 minutes and the reading displayed will slowly increase to ambient. **Do not make any adjustments to the reading until after the monitor has been powered for at least an hour.**

NOTE: When the PureAire O₂ monitor is supplied with an Audio Horn, it will activate momentarily at the completion of the warmup.

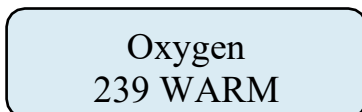

Oxygen
239 WARM

NOTE: The PureAire O₂ monitor's reading may be adjusted to the ambient oxygen level. See section 3.10.1. for instructions on adjusting.

3.7. Normal Operation

The PureAire O₂ monitor is a single-point monitor designed for the continuous detection and measurement of ambient oxygen concentration levels.

3.7.1. Signal Outputs

The PureAire O₂ monitor outputs a continuous 4-20 mA analog signal proportional to the measured concentration of oxygen. 4 mA represents 0% O₂ and 20 mA represents 25% O₂ which is the full range. In the event of a system fault, a specific factory-defined code will be displayed on the local digital display. This code will indicate the exact nature of the system fault.



CAUTION

DO NOT connect to a powered current loop receiver. The PureAire Oxygen monitor supplies the current loop power.

3.7.2. Instrument Faults

The PureAire O₂ monitor incorporates several self-checking features to ensure reliable operation. In the event that a fault condition is detected, the analog output signal is altered: Examples of some common error codes are displayed in the following table:

Condition	Analog Signal
**Supply Voltage Out of Range Fault code 16	Analog output drops to 2 mA
Transmitter cable cut	Analog output drops to 0 mA
O ₂ Cell complete failure Fault Code 128	Analog output drops to 2 mA Fault Relay activates (Available with Relay Option Only)
O ₂ System Warm Up	Analog output drops to 2 mA Fault Relay activates and turns off when the system is in the Oxygen operation mode (Available with Relay Option Only)
O ₂ Cell voltage fault Fault Code 64	Analog output drops to 2 mA Fault Relay activates (Available with Relay Option Only)
No Flow to the Oxygen sensor Fault Code 32	Analog output drops to 2 mA Fault Relay activates
EEPROM Fault 08	Analog output drops to 2mA

NOTE: All system faults are displayed on the front panel. Each fault has its own specific code to identify the specific problem. Please contact PureAire whenever a fault is displayed.

**** When using your own power supply, please ensure that the voltage is regulated to 24VDC +/- 0.5 volts. If the voltage is too low or high, you will activate a "Supply Voltage Out of Range fault and disable the monitor.****

*NOTE: If a Fault condition clears itself, (Yellow LED is no longer illuminated)
The Fault message will continue to scroll until manually cleared.*

To clear the fault message, **push the joystick down** ↓ (- Minus)

3.7.3. Routine Maintenance Schedule

Continuous gas detection systems depended upon to measure and detect hazardous gas leaks in the workplace require periodic maintenance to ensure proper operation. The frequency with which this routine maintenance is required depends on the environment. The following table is intended to serve as a general guideline for routine maintenance. The conditions in your particular application, as well as your organization’s maintenance policies, will ultimately determine the best routine maintenance schedule for your equipment. Routine Visual Checks

Items to check	Check for power and proper operation
Condition/status when operating properly	The unit should be outputting a 17.4 mA signal when the oxygen level is at 20.9%. The LCD digital display should also indicate 20.9% O ₂ when the oxygen is at ambient levels.

3.7.3.1. Recommended Routine Maintenance Schedule

Routine Visual Checks	Every 6 - 12 months
Sensor Verification with nitrogen	Every 6 -12months**

** The ambient oxygen level is 20.9%; therefore, under ambient conditions, visual verification of the PureAire O₂ monitor to 20.9% oxygen is easily performed. The O₂ monitor only requires periodic testing with nitrogen to verify the cell's response to low oxygen levels. See Section 3.9.10 for how to make minor adjustments.

3.7.4. Loss of Power Indicator

In the event the PureAire O₂ monitor loses 24VDC power, the 4-20 mA analog output signal drops to 0mA. The LCD display will also display a blank screen.

3.7.5. Alarm Reset

The PureAire O₂ DRA monitor is supplied with alarm relays, whenever the monitor's alarms are activated, the built-in alarm relays, panel-mounted LEDs and the audio horn will also activate. When the relay settings are non-latching, the alarm relays, LEDs, and the horn will automatically reset. If the relay settings are latching, then a manual reset of the alarms is required. Resetting the alarms can be performed through the use of the joystick or using the remote reset function.

Joystick – You must enter the password to enter the reset function. After the password is entered and accepted, push the joystick in; (enter) to reset the alarms.

Remote Reset – See section 2.2.3The alarm relay board has a two-pin connector for wiring to a remote switch. When connected to a switch, this remote reset will bypass the joystick and a password will not be needed to reset the alarms.

NOTE: The oxygen levels must recover above the alarm thresholds before the horn can be reset from the remote reset switch or joystick.

3.8. PureAire O₂ Monitor Programming

The PureAire O₂ Deficiency Monitor is supplied with user-selectable settings to adjust the alarm settings, 4 and 20mA output, and minor sensor adjustments.

The settings are arranged in menus that are accessed by moving the joystick. To access the menus a factory set password is used.

NOTE: The digital display is calibrated for oxygen. The range is stated on the model label and can also be accessed via the joystick on the front panel. In the measurement mode, pushing the joystick down will scroll the gas and range on the display. Pushing the joystick down again will stop the scrolling and display the gas again.

NOTE: The PureAire O₂ Deficiency Monitor will continuously monitor oxygen while accessing the menus. **The alarm, fault relays, and mA output are all active and on line while making any changes to the menus.**

3.8.1. Joystick Operation

The PureAire O₂ monitor uses a 4-position joystick with a center pushbutton for selecting menus and changing values. The joystick is programmed to the standard protocol as follows:

NOTE: *The joystick has a built-in delay to prevent accidental tampering with the menus. deliberate entries are required.*

CAUTION: *Only qualified personnel should perform programming, maintenance, and sensor verification*

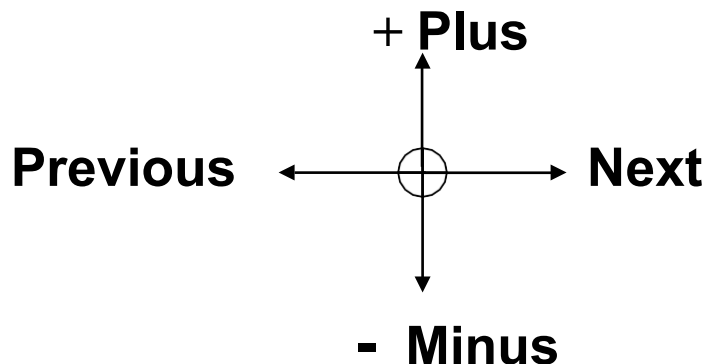

Plus – Pushing the joystick in this direction increases the value

Minus – Pushing the joystick in this direction decreases the value

Next – Pushing the joystick in this direction moves you to the next level of the menu hierarchy.

Previous – Pushing the joystick in this direction takes you out to the last level of menu hierarchy.

Enter – Pushing the joystick directly in the center enters the information into the microprocessor

3.8.2.

Program Flowchart

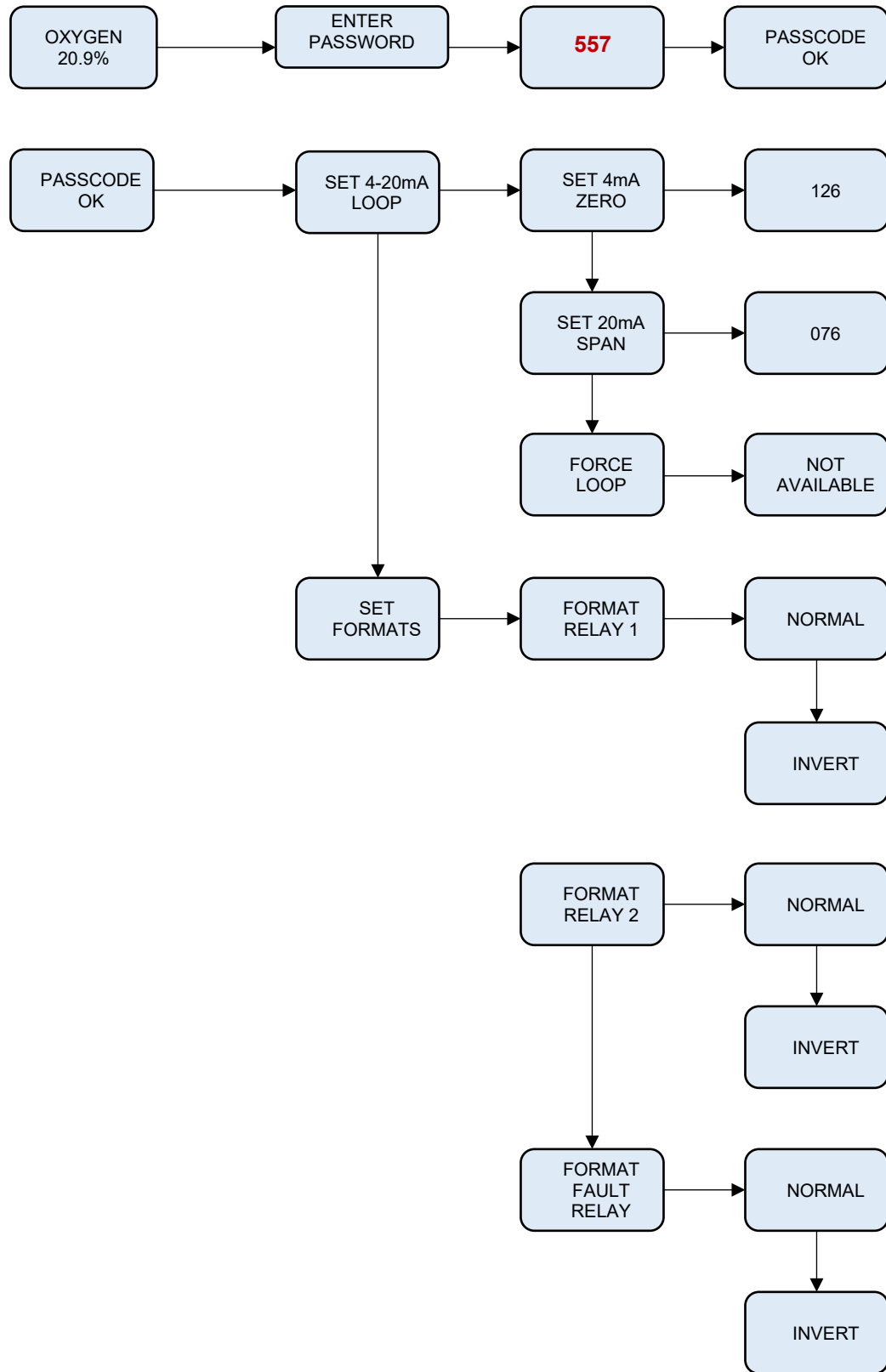

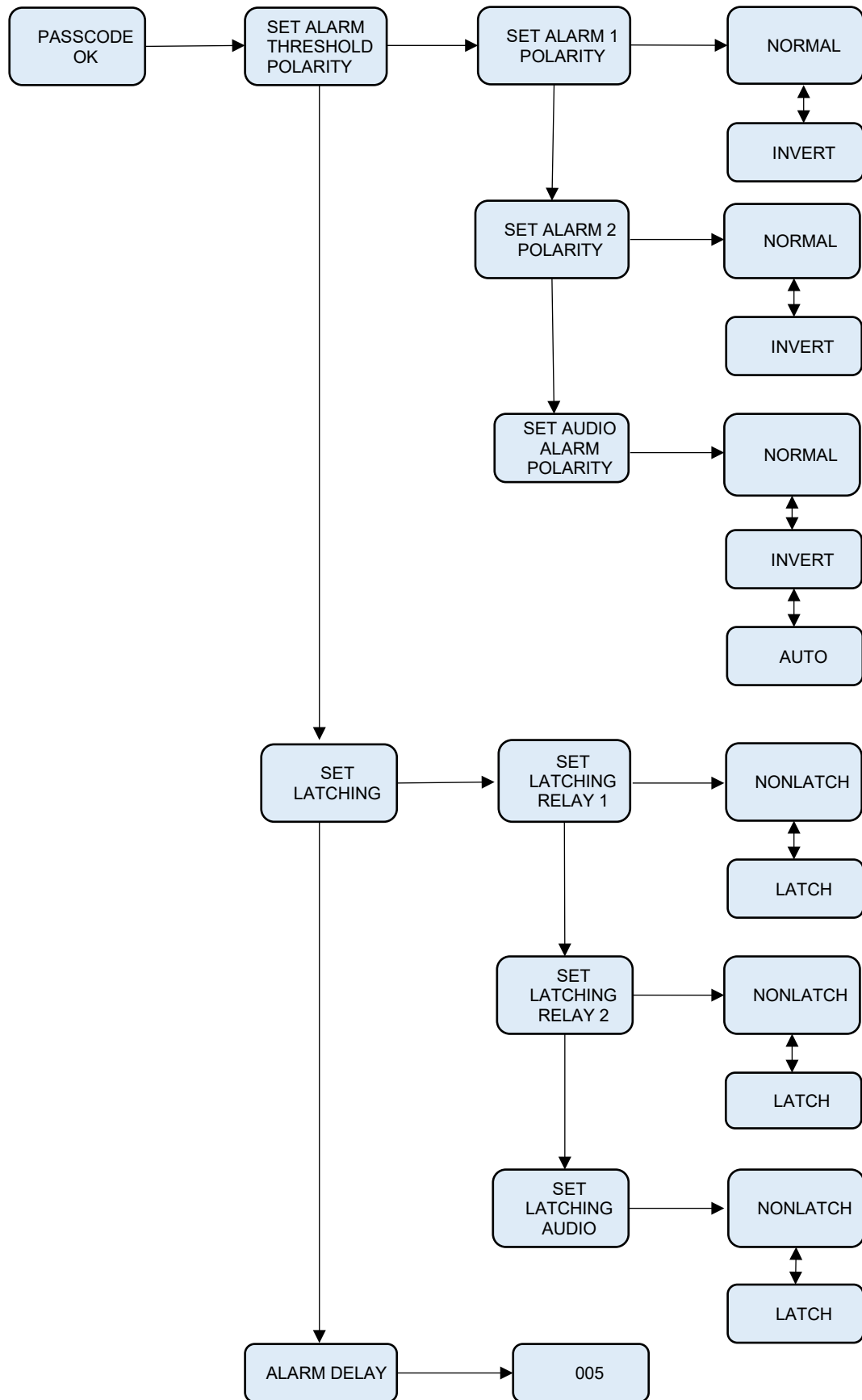

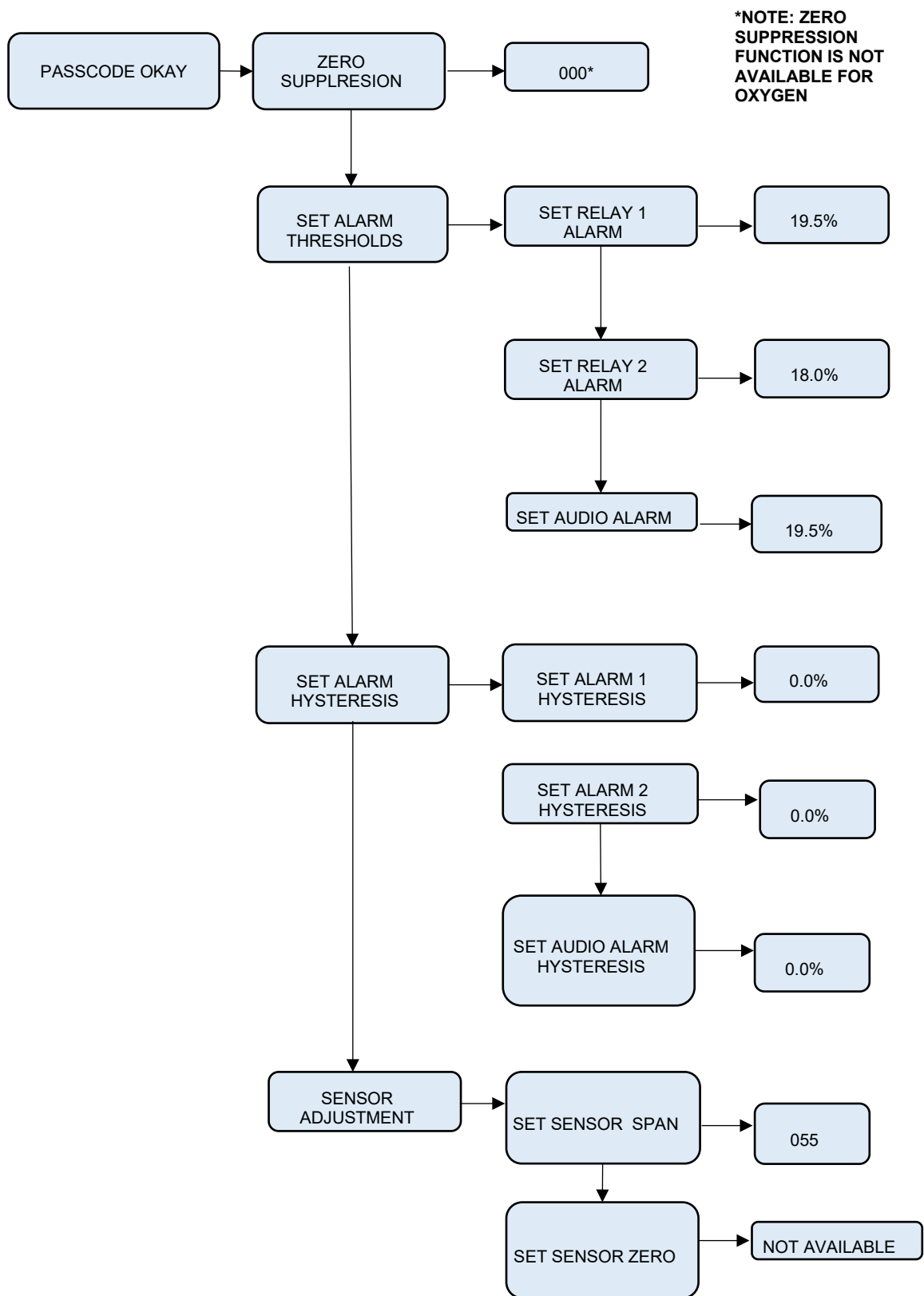

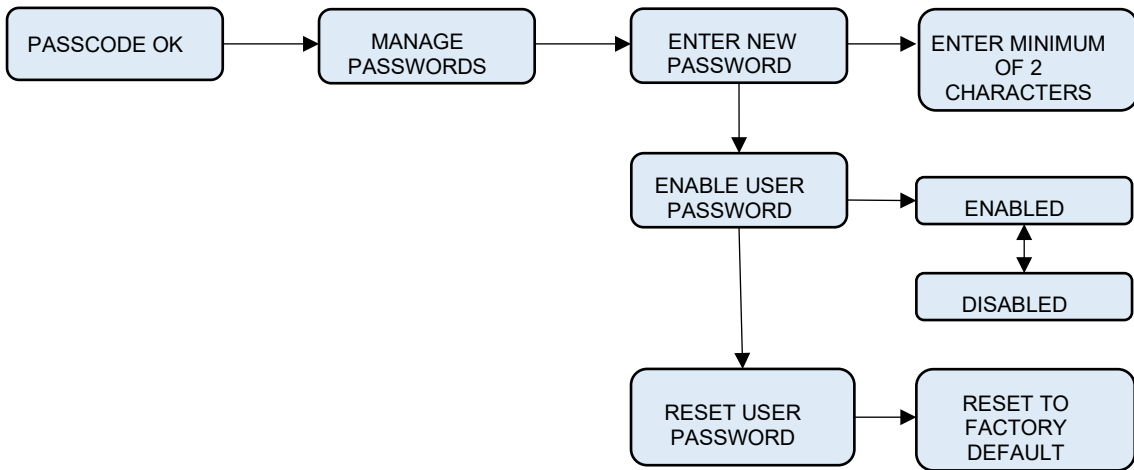

3.8.3. Entering the Password

The PureAire Oxygen monitor is supplied with a factory set password to prevent unauthorized access to the menus. **The Password is 557.** The following explains how to enter the password.

Push the joystick once to the right. **Enter Password** will scroll on the first line of the digital display. The second line will still display the current oxygen level.

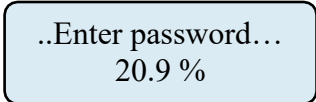

..Enter password...
20.9 %

Push the joystick again to the right to enter the input screen. **The letter A will appear and flash.**

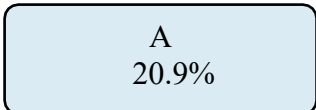

A
20.9%

NOTE: *The display has characters that start with A through Z and 0 through 9. Pushing the joystick up or down will permit you to scroll through the alphanumeric characters.*

Push the joystick up or down to enter the first digit. The display is an alphanumeric display and toggles from A through Z followed by 0 to 9. The character to be entered will flash.

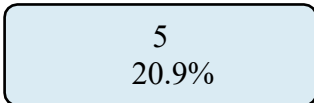

5
20.9%

Push the joystick again to the right to select the second entry. Push the joystick up or down to select the second digit. The character being entered will flash and the first character entered will remain lit.

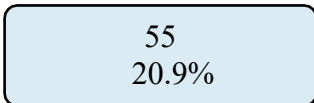

55
20.9%

Push the joystick again to the right to select the third entry. Push the joystick up or down to select the third and final digit. The character being entered will flash and the first and second characters entered will remain lit. You are now ready to enter the 3-digit password.

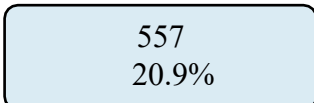

557
20.9%

Push the joystick in the center to enter the password. If you entered it correctly the display will scroll **Password OK.**

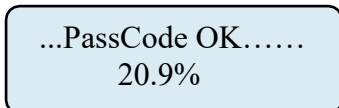

...PassCode OK.....
20.9%

NOTE: *If an incorrect password has been entered, the display will indicate Password Failed. Push the joystick to the left to access the monitoring mode. From this mode, you can reenter the password again.*

3.8.3.1. Changing the User Password

The PureAire Oxygen monitor is supplied with a factory set password to prevent unauthorized access to the menus. The user can change this password and the following explains how to change the password.

Push the joystick down to access the **Manage Passwords Menu**. **Manage Passwords** will scroll on the first line of the digital display. The second line will still display the current oxygen level.

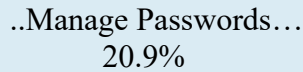

..Manage Passwords...
20.9%

Push the joystick to the right to enter the input screen. **Enter New User Password** will scroll on the first line of the digital display

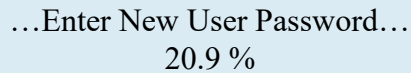

...Enter New User Password...
20.9 %

Push the joystick to the right to enter the input screen. **The letter A will appear and flash.**



A
20.9%

NOTE: *The display has characters that start with A through Z and 0 through 9. Pushing the joystick up or down will permit you to scroll through the alphanumeric characters.*

Push the joystick up or down to enter the first digit. The display is an alphanumeric display and toggles from A through Z followed by 0 to 9. The character to be entered will flash.



2
20.9%

Push the joystick again to the right to select the second entry. Push the joystick up or down to select the second digit. The character being entered will flash and the first character entered will remain lit.



25
20.9%

Push the joystick again to the right to select the third entry. Push the joystick up or down to select the third and final digit. The character being entered will flash and the first and second characters entered will remain lit. You are now ready to enter the 3-digit password.

253
20.9%

Push the joystick in the center to enter the password. This will display the next command, **Re-Enter New Password**

...Re-Enter New Password...
20.9 %

Push the joystick to the right to enter the input screen. **The letter A will appear and flash.**

A
20.9%

Push the joystick up or down to enter the first digit. The display is an alphanumeric display and toggles from A through Z followed by 0 to 9. The character to be entered will flash.

2
20.9%

Push the joystick again to the right to select the second entry. Push the joystick up or down to select the second digit. The character being entered will flash and the first character entered will remain lit.

25
20.9%

Push the joystick again to the right to select the third entry. Push the joystick up or down to select the third and final digit. The character being entered will flash and the first and second characters entered will remain lit. You are now ready to enter the 3-digit password.

253
20.9%

Push the joystick in the center to enter the password. If you entered it correctly the display will scroll **“New Password Entry OK”**.

...New Password Entry OK...
20.9%

NOTE: If on the second entry the password entered was different from the first, the display will take you back to the “Re-enter Password Screen”. You will need to repeat steps 2 through 11. If you do not enter the password correctly, the monitor remembers the last password that was properly input.

3.8.3.2. Enable User Password

This menu permits the user to activate or disable the password function on the Oxygen monitor. Push the joystick down. “**Enable User Password**” will scroll on the first line of the digital display

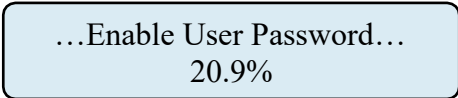

Push the joystick right to display the status. If enabled it will display “**Enabled**”

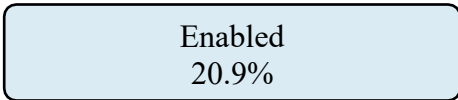

Push the joystick up or down to change the status. Once enabled or disabled is selected, Push the joystick in the center to enter the new status. If entered correctly the display will scroll “**Enable User Password**”

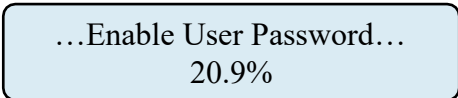

3.8.3.3. Reset User Password

This menu permits you to reset **the password back to 557, as set at the factory.**

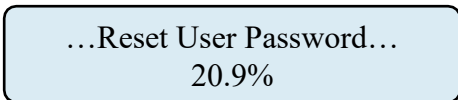

Push the joystick right to display the menu, “**Reset to factory Default**”.

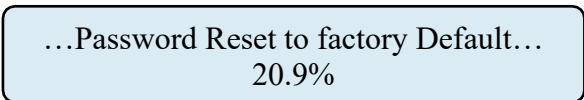

Push the joystick in, (like a doorbell) to reset the password back to 557.
Push the joystick left 4 times to go back to the measuring mode.

NOTE: If you lose your password please contact PureAire with your serial number or DTM number

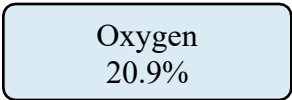

3.9. Entering the Menus

The PureAire O₂ monitor is supplied with main menus with sub-menus to adjust mA outputs, alarm relay settings, sensor adjustments, and zero suppression for toxic and corrosive gas sensor cells.

3.9.1. **Set 4-20mA loop**

.Set 4-20mA loop..
20.9%

This main menu will permit the adjusting of the 4mA and 20mA output from the PureAire O₂ Monitor. It also provides a function that will send an actual output between 4mA and 20 mA to test any remote control and alarm system attached to the O₂ monitor.

***NOTE:** To read the mA output, the PureAire O₂ monitor must either be connected to a remote PLC controller or SCADA system. You can also connect the PureAire O₂ monitor to a voltmeter to read the mA output. Please consult PureAire for more information.*

From this main menu, pushing the joystick to the right will select the sub-menu and the digital display will scroll the following:

..Set 4mA zero...
20.9%

This is the menu at which to adjust the 4mA output being sent from the PureAire O₂ Monitor.

To change this value, push the joystick right to display the 4 mA setting. The display will indicate a value between 0 and 255 counts. Pushing the joystick up increases the value and pushing the joystick down decreases the value. The 4mA output being sent from the PureAire O₂ monitor will change as the number on the digital display changes. Press **ENTER** to accept the value.

255
20.9%

Push the joystick to the left to bring you back to the previous Main menu. The digital display will scroll the following:

...Set 4mA zero.....
20.9%

Push the joystick down to access the next sub-menu; **Set 20mA Span will scroll.**

...Set 20mA Span...
20.9%

This is the menu at which to adjust the 20mA output being sent from the PureAire O₂ Monitor.

To change this value, push the joystick right to display the 20mA span setting. The display will indicate a value between 0 and 255 counts. Pushing the joystick up increases the value and pushing the joystick down decreases the value. The 20mA output being sent from the PureAire O₂ monitor will change as the number on the digital display changes. Press **ENTER** to accept the value.



255
20.9%

Push the joystick to the left to bring you back to the previous Main menu. The digital display will scroll the following:

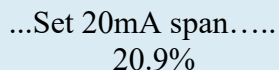

...Set 20mA span.....
20.9%

Push the joystick down to access the next sub-menu; **Force loop will scroll.**

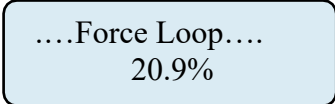

....Force Loop....
20.9%

NOTE: The Force Loop function is not available on the PureAire O₂ monitor. It was designed for toxic and corrosive gases.

This sub-menu is only used on PureAire's toxic and corrosive monitors.

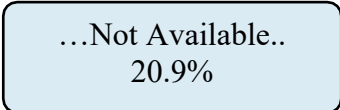

...Not Available..
20.9%

Push the joystick to the left to bring you back to the previous menu. The digital display will scroll the following:

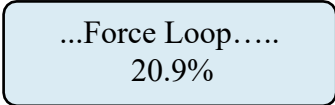

...Force Loop.....
20.9%

NOTE: When adjusting the 4 mA and 20mA settings, the actual reading may quickly switch from your setting and an alternate number. This is a run-time indication and is normal.

Set Formats

This is the menu at which to adjust the relay states for the two gas alarm relays and the individual instrument fault relay.

NOTE: *The O₂ system must have the relay module installed to access this menu. If no relay module is installed the display will indicate N/A, (not available)*

Push the joystick down to access the next main menu, **Set Formats**. The display will scroll the following:

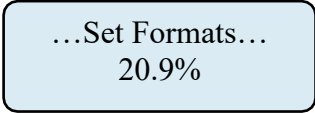

...Set Formats...
20.9%

This menu will permit the setting of the two alarm relays and the fault relay settings from normally de-energized state, **Normal**, to normally energized state, **Inverted**.

From this main menu, pushing the joystick to the right will select the sub-menu and the digital display will scroll the following:



..Format Relay 1...
20.9%

This is the menu at which to adjust the first level alarm relay state on the PureAire O₂ Monitor.

To change this value, push the joystick right to display the relay state. The display will indicate **INVERT**. Pushing the joystick down will change the relay state from **INVERT** to **NORMAL**. Press **ENTER** to accept the value.

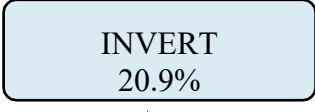

INVERT
20.9%

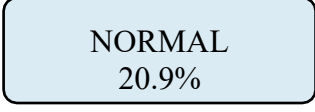
NORMAL
20.9%

After entering the relay state, the display will default back to the Set Formats menu. The display will scroll the following:

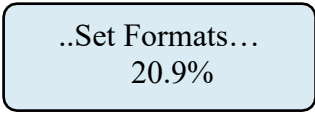

..Set Formats...
20.9%

From this main menu, pushing the joystick to the right will select the sub menu and the digital display will scroll the following:

..Format Relay 1...
20.9%

Push the joystick down to access the next main menu, **Set Formats**. The display will scroll the following:

... Format Relay 2..
20.9%

This is the menu at which to adjust the second level alarm relay state on the PureAire O₂ Monitor.

To change this value, push the joystick right to display the relay state. The display will indicate **INVERT**. Pushing the joystick down will change the relay state from **INVERT** to **NORMAL**. Press **ENTER** to accept the value.

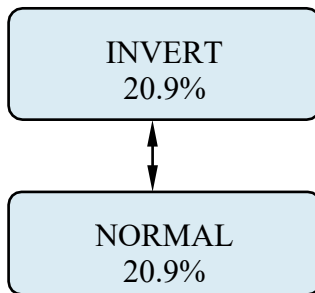

After entering the relay state, the display will default back to the Set Formats menu. The display will scroll the following:

..Set Format ...
20.9%

From this main menu, pushing the joystick to the right will select the sub-menu and the digital display will scroll the following:

..Format Relay 1...
20.9%

Push the joystick twice to select the fault relay to be adjusted. The display will scroll: **Format Fault Relay**.

..Format Fault Relay...
20.9%

This is the menu at which to adjust the fault alarm relay state on the PureAire O₂ Monitor.

To change this value, push the joystick right to display the relay state. The display will indicate **INVERT**. Pushing the joystick down will change the relay state from **INVERT** to **NORMAL**. Press **ENTER** to accept the value.

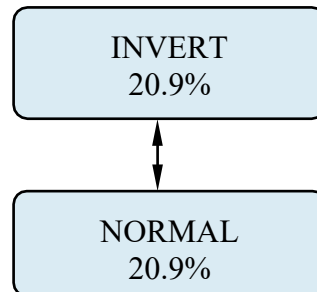

After entering the relay state, the display will default back to the Set Formats menu. The display will scroll the following:

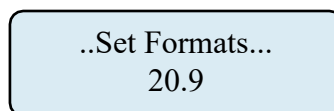

3.9.3. Set Alarm Threshold Polarity

Alarm Threshold Polarity determines if an alarm concentration is set above or below a threshold value. For example, if an alarm of 19.0% for Oxygen is selected, the Alarm Threshold Polarity must be set to **Invert** for the monitor's alarm to activate when the reading goes below 19.0%. For toxic and corrosive gases selecting a **Normal** setting for the Alarm Threshold Polarity means that the system will alarm when the gas concentration exceeds, goes above, an alarm set point. This menu will permit the selection of the alarm polarity. To access this menu from the "Set Formats" menu, push the joystick down to display the **Set Alarm Threshold Polarity** adjustment menu. This will scroll on the digital display.

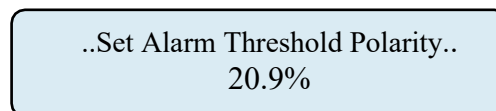

Push the joystick right to access the first sub-menu; **Set Alarm 1 Polarity** will scroll on the display. This is the menu at which to adjust the first level alarm polarity state on the PureAire O₂ Monitor.

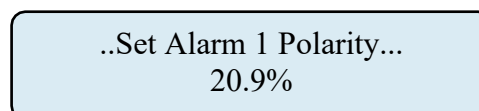

To change this value, push the joystick right to display the relay state. The display will indicate **INVERT**. Pushing the joystick down will change the relay state from **INVERT** to **NORMAL**. Press **ENTER** to accept the value.

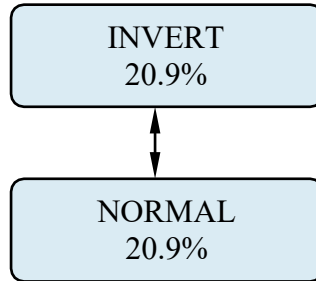

After entering the relay state, the display will default back to the Set Alarm 1 Polarity menu. The display will scroll the following:

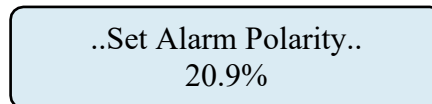

Push the joystick down to access the next sub-menu; **Set Alarm 2 Polarity** will scroll on the display. This is the menu at which to adjust the second level alarm polarity state on the PureAire O₂ Monitor.

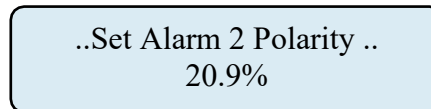

To change this value, push the joystick right to display the relay state. The display will indicate **INVERT**. Pushing the joystick down will change the relay state from INVERT to NORMAL. Press **ENTER** to accept the value.

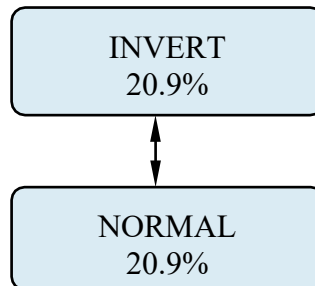

After entering the relay state, the display will default back to the Set Relay 2 Alarm Threshold menu. The display will scroll the following:

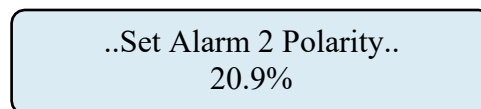

Push the joystick down to access the next sub-menu; **Set Audio Alarm Polarity** will scroll on the display. This is the menu at which to adjust the second level alarm polarity state on the PureAire O₂ Monitor.

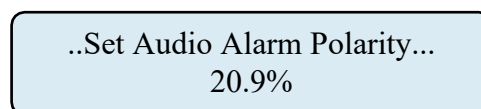

NOTE: The O₂ system must have the audio alarm option module installed to access this menu. If this option is installed the display will indicate N/A, (not

available).

NOTE: The built-in horn is designed to operate in only one alarm mode. It will activate in either a decreasing alarm or an increasing alarm mode only. The horn activation is immediate any time an alarm threshold is exceeded.

To change this value, push the joystick right to display the relay state. The display will indicate **INVERT**. Pushing the joystick down will change the relay state from **INVERT** to **NORMAL**. Press **ENTER** to accept the value.

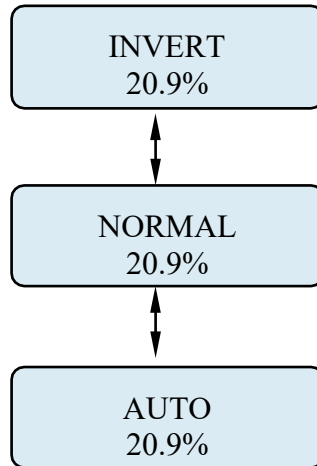

Auto Mode - The auto mode is used when you wish the horn to activate at the same time the relays activate. In the Normal or Inverted Mode, the horn immediately activates any time the alarm thresholds are exceeded. To activate the horn when the relays activate, choose the **AUTO** mode.

After entering the relay state, the display will default back to the **Set Audio Alarm Polarity** menu. The display will scroll the following:

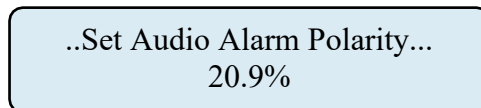

394.

Set Latching

This is the menu at which to adjust the relay alarm state for the two gas alarm relays and the individual instrument fault relay. The selection permits setting the relays to a latching or non-latching state. In a latching state, the relay will remain activated until the user manually selects the Enter Key. In a non-latching state, the alarm relay will automatically reset once the gas concentration has returned to 20.9% for oxygen.

NOTE: The O_2 system must have the relay module installed to access this menu. If no relay module is installed the display will indicate *N/A, (not available)*

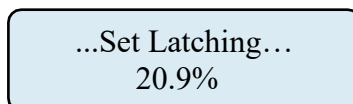

This menu will permit the setting of the two alarm relays and the fault relay settings from a latching to a non-latching state when they are activated.

From this main menu, pushing the joystick to the right will select the sub-menu and the digital display will scroll the following:

..Set Latching Relay 1...
20.9%

This is the menu at which to adjust the first level alarm relay state on the PureAire O₂ Monitor.

To change this value, push the joystick right to display the relay state. The display will indicate **LATCH**. Pushing the joystick down will change the relay state from **LATCHING** to **NON-LATCHING**. Press **ENTER** to accept the value.

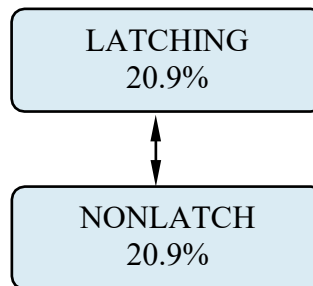

After entering the relay state, the display will default back to the **Set Latching** menu. The display will scroll the following:

..Set Latching....
20.9%

From this main menu, pushing the joystick to the right will select the sub-menu and the digital display will scroll the following:

..Set Latching Relay 1...
20.9%

Push the joystick down to select the next relay to be adjusted. The display will scroll the following, **Set Latching Relay 2**.

..Set Latching Relay 2...
20.9%

This is the menu at which to adjust the second level alarm relay state on the PureAire O₂ Monitor.

To change this value, push the joystick right to display the relay state. The display will

Indicate **LATCHING**. Pushing the joystick down will change the relay state from LATCHING to NONLATCH. Press **ENTER** to accept the value.

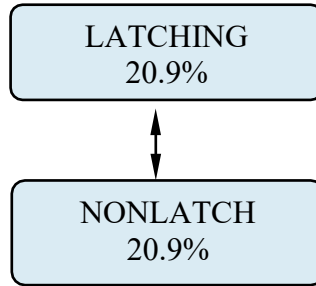

After entering the relay state, the display will default back to the **Set Latching** menu. The display will scroll the following:

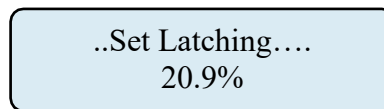

From this main menu, pushing the joystick to the right will select the sub-menu and the digital display will scroll the following:

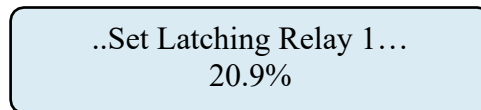

Push the joystick twice to select the Audio Alarm relay to be adjusted. The display will scroll; **Set Latching Audio Alarm**.

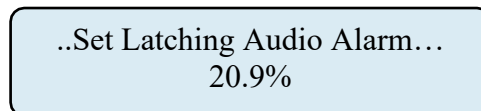

This is the menu at which to adjust the Audio alarm relay state on the PureAire O₂ Monitor.

NOTE: *The O₂ system must have the audio alarm option module installed to access this menu. If this option is installed the display will indicate N/A, (not available)*

To change this value, push the joystick right to display the relay state. The display will indicate **LATCHING**. Pushing the joystick down will change the relay state from LATCHING to NONLATCH. Press **ENTER** to accept the value.

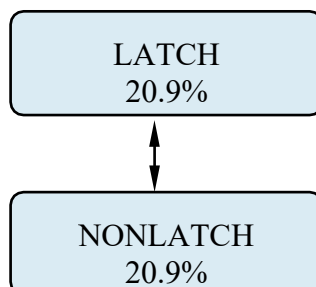

After entering the fault relay state, the display will default back to the **Set Latching** menu. The display will indicate the following:

..Set Latching....
20.9%

3.9.5. **Resetting a Latching Alarm**

To reset a latching alarm relay, you must enter the password correctly and then push the joystick down to enter the reset command. The Oxygen monitor also has an internal 2-pin terminal block for connecting a remote reset switch. (See Alarm Relay board, section 1.2.7)

3.9.6. **Set Alarm Delay**

Push the joystick down to access the next main menu, **Alarm Delay**. The display will scroll the following:

...Alarm Delay...
20.9%

This is the amount of time an alarm level concentration of oxygen must be present before the instrument's gas concentration alarm(s) will be activated. This menu will permit setting a user-selected time delay for activating alarm relays 1 and 2. You can select from 0 seconds up to 255 seconds after an alarm level has been exceeded before the alarm relays to activate.

To change this value, push the joystick right to display the time screen. The display will indicate a value between 0 and 255 seconds. Pushing the joystick up increases the value and pushing the joystick down decreases the value. Press **ENTER** to accept the value.

005
20.9%

After entering the alarm delay, the display will default back to the Alarm Delay menu and the display will scroll the following:

...Alarm Delay...
20.9%

NOTE: The alarm delay is only available for alarms 1 and 2. There is no delay for the fault relay. Any system fault will immediately activate the Fault Relay.

39.7. Set Zero Suppression

This function is not used on the Oxygen monitor. It is only used to decrease the sensitivity of selected gas sensors. Although the menu permits the changing of settings, it is disabled in the Oxygen monitor. The factory default is set at 000.

NOTE: This function is not available on the PureAire Oxygenmonitor.

...Zero Suppression...
000

39.8. Set Alarm Thresholds

..Set Alarm Thresholds..
20.9%

This main menu will permit adjusting the oxygen concentration percentage that will activate alarm levels 1 and 2. It also permits setting the level at which the audio alarm will activate.

From this main menu, pushing the joystick to the right will select the first sub-menu and the digital display will scroll the following: **Set Relay 1 Alarm Threshold.**

..Set Relay 1 Alarm Threshold...
20.9%

This is the gas concentration at which the instrument's first level alarm will be activated. To change the displayed value, push the joystick to the right to display the first-level alarm setting. The display will indicate a value between 00.0% and 25.5%.

Pushing the joystick up increases the value and pushing the joystick down decreases the value. Press **ENTER** to accept the value.

19.5%
20.9%

After entering the relay state, the display will default back to the **Set Relay 1 Alarm Threshold** Menu. The display will scroll the following:

..Set Relay 1 Alarm Threshold...
20.9%

Push the joystick down to access the next sub-menu; **Set Relay 2 Alarm Threshold**, will scroll on the digital display.

..Set Relay 2 Alarm Threshold...
20.9%

This is the gas concentration at which the instrument's second-level alarm will be activated. To change the displayed value, push the joystick to the right to display the second-level alarm setting. The display will indicate a value between 00.0% and 25.5%.

Pushing the joystick up increases the value and pushing the joystick down decreases the value. Press **ENTER** to accept the value.

18.0%
20.9%

After entering the relay state, the display will default back to the **Set Relay 2 Alarm Threshold** Menu. The display will scroll the following:

..Set Relay 2 Alarm Threshold...
20.9%

Push the joystick down to access the next sub-menu; **Set Audio Alarm Threshold**, will scroll on the digital display.

..Set Audio Alarm Threshold...
20.9%

This is the gas concentration at which the instrument's audio alarm will be activated. To change the displayed value, push the joystick to the right to display the second-level alarm setting. The display will indicate a value between 00.0% and 25.5%.

Pushing the joystick up increases the value and pushing the joystick down decreases the value. Press **ENTER** to accept the value.

NOTE: The O₂ system must have the audio alarm option module installed to access this menu. If this option is installed the display will indicate N/A, (not available)

19.5%
20.9%

NOTE: The audio can be set to only one alarm level. You can choose between alarm level 1 or alarm level 2 or set a completely different setting.

After entering the relay state, the display will default back to the **Set Audio Threshold** Menu. The display will scroll the following:

..Set Audio Alarm Threshold...
20.9%

3.9.9. Set Alarm Hysteresis

PureAire's oxygen monitor may be used as a control system. When used to regulate oxygen levels the need of a dead band, "hysteresis" may be required for the alarm relays. This menu will permit the setting of the alarm hysteresis to a desired concentration of Oxygen. When using hysteresis, the alarm set point now becomes an average alarm setting for an action to occur. When adding the hysteresis value to the alarm set point, this then defines the alarm and dead band for an action to occur.

For example, if you require a valve to close at 14.9% oxygen level and to reopen again at 15.5% oxygen level, you will set the Alarm Threshold at 15.2% and set the hysteresis value at 0.3%.

Average Alarm set point = 15.2% - Hysteresis 0.3% = 14.9%, Valve Off
Average Alarm set point = 15.2% + Hysteresis 0.3% = 15.5%, Valve On

To access this menu, push the joystick down to display the **Set Alarm Hysteresis** menu. This will scroll on the digital display.

..Set Alarm Hysteresis...
20.9%

Push the joystick right to access the **Set Alarm 1 Hysteresis**. Pushing the joystick again to the right will display a value 0.0%, (factory default). Pushing the joystick up increases the percentage up to a maximum value of 2.5%. Adjust the digital display until the desired hysteresis value is selected.

0.3%
20.9%

Press **ENTER** to accept this value. The digital display will revert to **Set Alarm 1 Hysteresis**.

..Set Alarm 1 Hysteresis...
20.9%

Push the joystick down to access the next sub-menu; **Set Alarm 2 Hysteresis** will scroll on the digital display. Pushing the joystick again to the right will display a value 0.0%. Pushing the joystick up increases the percentage up to a maximum value of 2.5%. Adjust the digital display until the desired hysteresis value is selected.

..Set Alarm 2 Hysteresis...
20.9%

Press **ENTER** to accept this value. The digital display will revert to **Set Alarm 2 Hysteresis**.

..Set Alarm 2 Hysteresis...
20.9%

Push the joystick down to access the next sub-menu; **Set Alarm Audio Hysteresis** will scroll on the digital display. Pushing the joystick again to the right will display a value 0.0%. Pushing the joystick up increases the percentage up to a maximum value of 2.5%. Adjust the digital display until the desired hysteresis value is selected.

..Set Audio Alarm Hysteresis...
20.9%

3.9.10. Set Sensor Adjust

This menu will permit fine-tuning of the oxygen readout to a known concentration of Oxygen. It is recommended to adjust the oxygen display to ambient oxygen levels of 20.9%. To access this menu, push the joystick down to display the **Sensor Adjustment** menu. This will scroll on the digital display.

NOTE: It is recommended to warm up the PureAire Oxygen monitor for two hours before making any adjustments to the sensor.

..Sensor Adjustment...
20.9%

Push the joystick right to access the first sub-menu; **Set Sensor Span** will scroll on the display. This is the menu that will permit fine adjustment of the ambient oxygen reading to 20.9%.

..Set Sensor Span..
20.9%

Push the joystick right to access the sensor span. The display will indicate a value between 0 and 255 counts. Pushing the joystick up increases the counts and decreases the percent oxygen value displayed on the PureAire. Pushing the joystick down decreases the counts and increases the oxygen value displayed on the PureAire. As the counts increase and decrease the percent oxygen displayed will also increase and decrease. Adjust the digital display until 20.9% +/- 0.1% is displayed. The actual oxygen reading will fluctuate from 20.8% to 21.0%.

093
20.9%

Press **ENTER** to accept this value. The digital display will revert to **Set Sensor Span**.

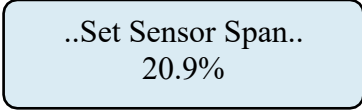

..Set Sensor Span..
20.9%

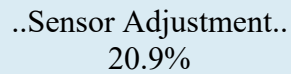

..Sensor Adjustment..
20.9%

Press the joystick to the left to revert to the **Sensor Adjustment** menu.

NOTE: The “Set Module Zero” menu is not available for the Oxygen monitor. This menu was designed for PureAire toxic and corrosive gas monitors. When selected, nothing will happen. Push the joystick Left to leave this menu.

3.9.11. **Main Operation Mode**

To select the main menu from any sub-menu, push the joystick left until the Main Menu appears. The digital display will indicate the following:

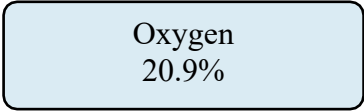

Oxygen
20.9%

3.10. Maintenance & Sensor Verification

Only qualified personnel should perform maintenance and sensor verification

3.10.1. **Sensor Verification**

The earth is a stable source of calibrated oxygen at 20.9%, therefore under ambient conditions, you can perform a visual verification of the PureAire O₂ monitor to verify its reading at 20.9%. The O₂ monitor only requires periodic testing with nitrogen to verify the cell's response to low oxygen levels and, if needed, a slight annual adjustment of the sensor span to 20.9%.

3.10.1.1. **Sensor Verification Gas**

For testing the PureAire O₂ monitor, PureAire recommends using nitrogen. This can be purchased from PureAire or from your gas supplier.

3.10.1.2. **Sensor Verification Equipment**

This can be purchased from PureAire or from your gas supplier.

Part Number	Description	Quantity
94006-Demand Flow Regulator	Nitrogen 103 liter cylinder, 99.99% Oxygen 103 liter cylinder, 8% Demand Flow Regulator, C-10 2ft length of 1/8"ID 1/2" OD Tubing Carrying Case	1 each
94019-Ultra Zero Grade Air	Ultra Zero Grade Air 103 liter cylinder	1

***For Calibration Kit replacement items, please contact PureAire.**

NOTE: If the instrument is connected to a controller, set the controller to the standby mode to avoid accidental alarms.

NOTE: If your safety protocol requires, you may subject the monitor to different concentrations of oxygen span gas.

3.10.2

Sensor Verification Procedure

CAUTION: *Be sure to observe all safety guidelines when generating and using nitrogen.*

Under ambient non-oxygen deficient environments, the PureAire O₂ monitor will indicate a display reading of 20.9%. As the sensor ages, the reading may decrease in value. The following procedure should be used to adjust the reading to 20.9%.

It is recommended to verify and adjust the sensor span to ambient 20.9% annually.

Ensure that the PureAire O₂ monitor is in a clean non-oxygen deficient environment.

Enter the password. ***Refer to Section 3.8.3***

Select the ***Sensor Adjust*** menu.

This menu will permit fine-tuning of the oxygen readout to a known concentration of Oxygen. It is recommended to adjust the oxygen display to ambient oxygen levels of 20.9%. To access this menu, push the joystick down to display the **Sensor Adjustment** menu. This will scroll on the digital display.

NOTE: It is recommended to warm up the PureAire Oxygen monitor for two hours before making any adjustments to the sensor.

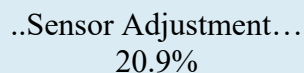

..Sensor Adjustment...
20.9%

Push the joystick right to access the first sub-menu; **Set Sensor Span** will scroll on the display. This is the menu that will permit fine adjustment of the ambient oxygen reading to 20.9%.

Push the joystick right to access the first sub-menu; **Set Sensor Span** will scroll on the display. This is the menu that will permit fine adjustment of the ambient oxygen reading to 20.9%.

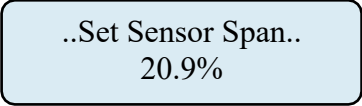

..Set Sensor Span..
20.9%

Push the joystick right to access the sensor span. The display will indicate a value between 0 and 255 counts. Pushing the joystick up increases the counts and decreases the percent oxygen value displayed on the PureAire. Pushing the joystick down decreases the counts and increases the oxygen value displayed on the PureAire. As the counts increase and decrease the percent oxygen displayed will also increase and decrease. Adjust the digital display until 20.9% + / - 0.2% is displayed.

093
20.9%

Press **ENTER** to accept this value. The digital display will revert to **Set Sensor Span**.

..Set Sensor Span..
20.9%

Press the joystick to the left to revert to the **Sensor Adjustment** menu.

...Sensor adjustment..
20.9%

3.10.2.1. Sensor Verification to Nitrogen

PureAire recommends challenging the O₂ monitor with nitrogen every 6 to 12 months. The sensor protector has a ¼” male tube fitting designed for connecting sample tubing from a Nitrogen cylinder. Expose the O₂ cell to N₂ at a flow rate of 500 cc/min. The reading will drop off to 1% or below in less than one minute when the O₂ sensor is exposed to pure N₂. The system will recover to 20.9% when the nitrogen is removed.

NOTE: The Sensor Protector has four air relief holes that will prevent the complete exposure of nitrogen to the oxygen sensor. To see a true zero oxygen level, the entire PureAire O₂ monitor needs to be completely immersed in a zero- oxygen environment. Covering the holes will help to prevent dilution of the span gas to ambient air.

3.10.2.2. Sensor Verification to a known concentration of Oxygen

When testing the O₂ monitor to a known concentration of oxygen, the sensor inlet has a ¼” compression tube fitting designed for connecting the sample tubing. You can connect ¼” OD sample tubing from a cylinder filled with Zero Grade air directly to the sensor protector and expose the O₂ cell directly at a flow rate of 500cc/min.

Expose the monitor for 1 minute and then adjust the reading to 20.9% when using Zero Grade air. Turn off the regulator and remove the Zero grade air from the monitor. The final reading should be within $\pm 0.3\%$ of the span gas concentration.

To see the exact span gas concentration the entire PureAire O₂ monitor needs to be completely immersed in the span gas environment.

NOTE: The Oxygen monitor should be tested in an upright position to allow the span gas to fully saturate the sensor cell.

NOTE: For best results, the Oxygen monitor should be protected from wind and high airflow when gas calibrating with test gas.

NOTE: To see a true zero, the entire PureAire O₂ monitor needs to be completely immersed in a zero-oxygen environment.

4: Carbon Dioxide Specifications

NOTE: *For our continual product improvement, all specifications are subject to change without notice.*

4.1. Performance Specifications Carbon Dioxide Sensor

Sensor Type:	Long Life NDIR Sensor 0-50,000ppm
Response Time:	Within 1 second of any change in CO ₂ .
Accuracy:	Accuracy: ± 300 ppm, $\pm 3\%$ of measured value
Fault Indicators:	Loss of VDC power (analog signal drops to 0 mA). Sensor cell failure: Fault relay activated. (Must have Alarm relay option for cell failure to operate)
Operating Temp:	32° to 122°F (0° to +50°C); consult PureAire for lower or higher operating temperatures.
Humidity:	0 to 95% RH.
Environment:	Altitude 2000 m, PSU only UL spec. Pollution Degree 3, Intended for Indoor Use.

4.2. Gas Detection System

Transmitter:	Microprocessor electronics with built-in 3-digit backlit LCD display Joystick operated menus
--------------	---

4.3. Signal Outputs

Standard	Analog Output:	DC 4-20 mA
Relay Output:	Dual level user selectable alarm relays and one fault relay Rated, 2amps @ 24VAC or 24VDC	

4.4. CO₂ System Default Factory Settings

The CO₂ Monitor is shipped with factory defaults for the alarm relay settings. The following are the factory defaults:

Menu Function	Factory Default	Menu Defined
Set 4-20mA loop	The mA output is set at the factory using a calibrated Fluke meter.	Use this function to adjust the monitor's 4mA, (Zero), and 20mA, (Span) to your PLC or distributive control system.
Set Formats LED and alarm relay State **	Alarm 1 = Normal Alarm 2 = Normal Fault = Normal	Do you want the relays to energize, (normal) or de-energize, (fail safe) when the alarm activates?
Set Alarm Threshold Polarity	Alarm 1 = Normal Alarm 2 = Normal Audio = Not Available	Do you want to alarm at a level higher, (normal) or lower, (inverted) than the alarm threshold?
Set Latching	Alarm 1 = Non-latching Alarm 2 = Non-latching Audio = Non-latching	Do you want the alarm to automatically reset? (non-latching) or do you want to manually reset the alarm? (latching)
Alarm Delay	Alarm = 5 seconds Displayed as 05	How long do you want to wait until the alarms activate?
Zero Suppression	0.0%	This function is Not Enabled on the CO₂ monitor.
Set Alarm Thresholds	Alarm 1 = 5,000ppm Alarm 2 = 10,000ppm	At what level do you want to alarm?
Set Alarm Hysteresis	Alarm 1 = 00 PPM Alarm 2 = 00 PPM	For use when using the CO ₂ monitor for control of valves and process.
Sensor Adjustment	Set CO ₂ Sensor span CO ₂ set to autocal on CO ₂ set to autocal off Calibrate CO ₂ to 400ppm	For use when manually gas calibrating the CO ₂ monitor. See Section 4.10
Manage Passwords	Factory default is 557	For use when changing the password from factory default to a new password of your choice.

NOTE: The built-in relay settings may be changed by the user in the field. Refer to Section 4.9.2.

NOTE: The LED indicators on the front panel are connected directly to the alarm relays.

4.5 Wiring

PureAire monitors require a 3-wire shielded cable for analog output and 24 VDC power input. A three-wire shielded cable; 3-conductor, 18 AWG-stranded General Cable E2203S.30.860, or equivalent is recommended for the connection. The analog out and VDC power in connections are made on the terminal block inside the monitor housing.



CAUTION: To avoid damaging the monitor, please rotate the front inside panel to the left when making relay connections. (See figure A)

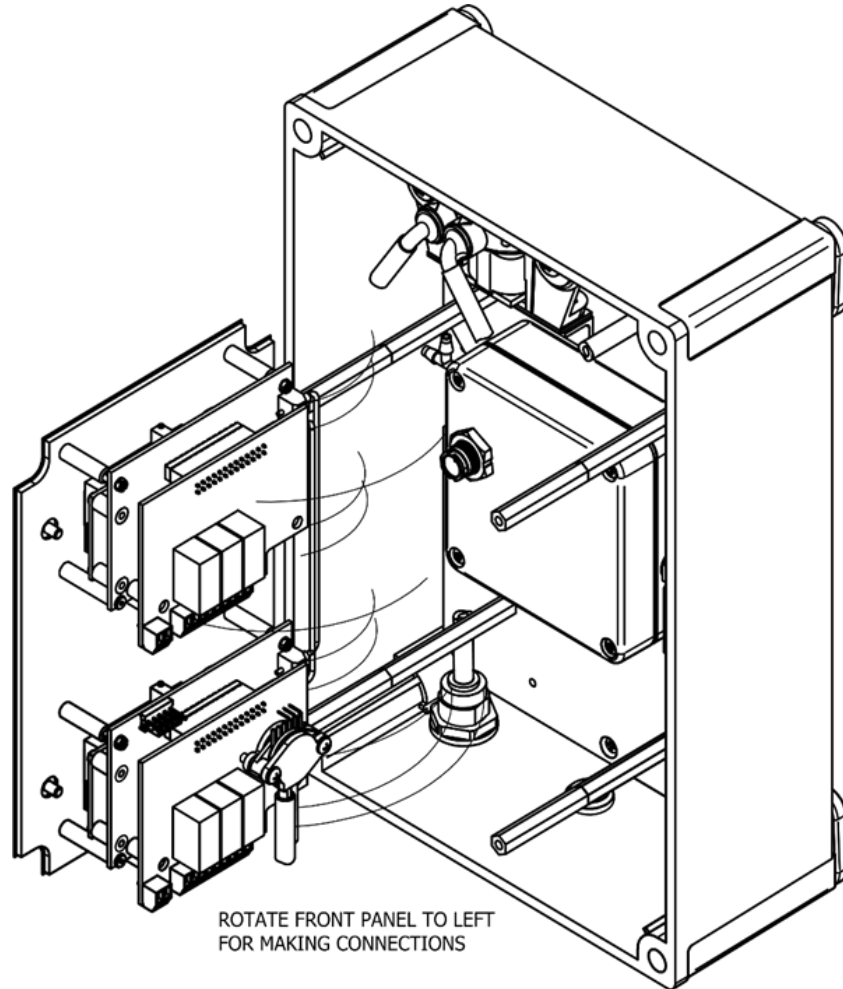
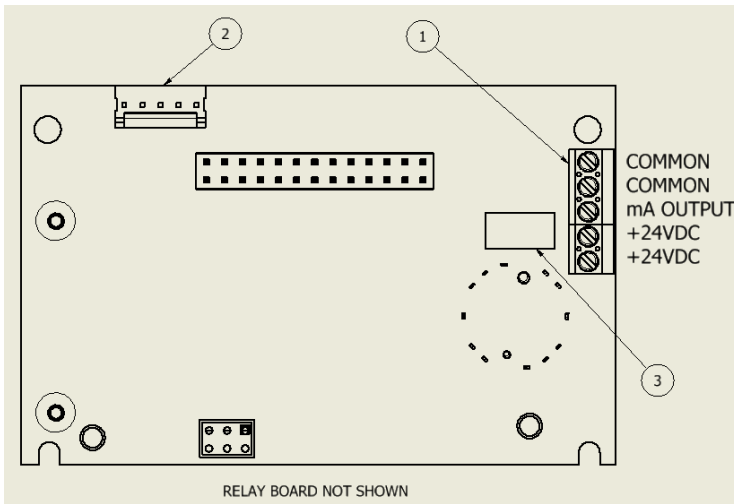

Figure A

These connections are made as follows:



PureAire provides the plug-in power supply



Caution

DO NOT connect to an active/powered current-loop receiver. The PureAire Carbon Dioxide monitor supplies the current loop power.

Pin #	Connection	Description
-	Common (Signal Ground)	0V
-	Common (Signal Ground)	0V
MA	Signal Out	DC 4-20mA Output
+	Power	DC + 24V Input
+	Power	DC + 24V Input

NOTE: *PureAire has added additional contacts for +24VDC power and Common to accommodate additional wiring for remote horns and strobes*

4.6. Initial Startup

Once the installation of the gas detector has been completed, it is ready for startup. The following procedures should be performed before putting the instrument into operation:

Check the integrity of all wiring.
Apply 24 VDC power.

The instrument should now be powered up. Upon power up, the **CO₂** monitor LCD displays the PureAire logo and then displays CO₂ on the top line and the actual PPM reading on the bottom line. The monitor will also output the proper mA signal to remote devices:

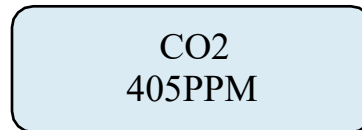

CO2
405PPM

NOTE: Ambient outdoor carbon dioxide levels are approximately 400ppm

4.7. Normal Operation

The CO_2 monitor is a single-point monitor designed for the continuous detection and measurement of ambient carbon dioxide concentration levels.

4.7.1. Signal Outputs

The CO_2 monitor outputs a continuous 4-20 mA analog signal proportional to the measured concentration of carbon dioxide. For CO_2 , 4 mA represents 0 PPM CO_2 , and 20 mA represents 50,000 PPM CO_2 which is the full range for carbon dioxide. In the event of a system fault, a specific factory-defined code will be displayed on the local digital display. This code will indicate the exact nature of the system fault.

4.7.2. Instrument Faults

The CO_2 monitor incorporates several self-checking features to ensure reliable operation. If a fault condition is detected, the analog output signal is altered: A few common error codes are displayed in the following table:

Condition	Analog Signal
**Supply Voltage Out of Range Fault code 16	Analog output drops to 2 mA Fault Relay activates
Transmitter cable cut	Analog output drops to 0 mA
CO_2 Cell complete failure Fault code 128	Analog output drops to 2 mA
EEPROM Fault 08	Analog output drops to 2mA Fault Relay activates
CO_2 sensor not responding Fault code F01	Analog output drops to 2mA Fault Relay activates

NOTE: All system faults are displayed on the front panel. Each fault has its own specific code to identify the specific problem. Please contact PureAire whenever a fault is displayed.

NOTE: When using your own power supply please ensure that the voltage is regulated to 24VDC +/- 0.5 volts. If the voltage is too low or high you will activate a "Supply Voltage Out of Range fault and disable the monitor.

4.8. Routine Maintenance Schedule

Continuous gas detection systems depended upon to measure and detect hazardous gas leaks in the workplace require periodic maintenance to ensure proper operation. The frequency with which this routine maintenance is required depends on the environment. The following table is intended to serve as a general guideline for routine maintenance. The conditions in your application, as well as your organization's maintenance policies, will ultimately determine the best routine maintenance schedule for your equipment. Routine Visual Checks.

Items to check	Check for power and proper operation
Condition/status when operating properly	The unit should be outputting approximately 4.6 mA signal when the carbon dioxide is at ambient 400ppm. The LCD digital display should also indicate approximately 405 ppm level when the carbon dioxide level is at ambient.

4.8.1. Recommended Routine Maintenance Schedule

Routine Visual Checks	Every 6 - 12 months
Sensor Verification with nitrogen	Every 6 -12months**

The ambient CO₂ level is 400ppm and the sensor provides automatic baseline adjustments to ambient levels on a regular schedule. However, the CO₂ sensor can be manually calibrated by using span gas. See section 4.10.2. for how to manually calibrate the CO₂ sensor.

4.8.2. Loss of Power Indicator

In the event the CO₂ monitor loses 24VDC power, the 4-20 mA analog output signal drops to 0mA. The LCD display will also display a blank screen.

4.8.3. Alarm Reset

The CO₂ monitor is supplied with individual alarm relays. Whenever the monitor’s alarms are activated, the built-in alarm relays, panel-mounted LEDs, and the audio horn will also activate. When the relay settings are non-latching, the alarm relays, LEDs, and the horn will automatically reset. If the relay settings are latching, then a manual reset of the alarms is required. Resetting the alarms can be performed through the use of the joystick or using the remote reset function.

Joystick – You must enter the password **557**, to enter the reset function. After the password is entered and accepted, push the joystick in; (enter) to reset the alarms.

Remote Reset – See section 2.3.3. The alarm relay board has a two-pin connector for wiring to a remote switch. When connected to a switch, this remote reset will bypass the joystick and a password will not be needed to reset the alarms.

NOTE: The carbon dioxide levels must recover above the alarm thresholds before the horn can be reset from the remote reset switch or joystick.

4.9. Carbon Dioxide Programming

The CO_2 monitor is supplied with user-selectable settings to adjust the alarm settings, 4 and 20mA output, and minor sensor adjustments. The settings are arranged in menus that are accessed by moving the joystick. To access the menus a factory set password is used.

Note: Local Display: Digital display calibrated for **Carbon Dioxide**. The range is stated on the model label and can also be accessed via the joystick on the front panel. In the measurement mode pushing the joystick down will scroll the gas and range on the display. Push the joystick down again to stop the scrolling and display the gas again.

NOTE: The CO_2 monitor will continuously monitor levels while accessing the menus. The alarm, fault relays, and mA output are all active and online while making any changes to the menus.

4.9.1. Joystick Operation

The CO_2 monitor uses a 4-position joystick with a center pushbutton for selecting menus and changing values. The joystick is programmed to the standard protocol as follows:

NOTE: *The joystick has a built-in delay to prevent accidental tampering with the menus. deliberate entries are required.*

CAUTION: *Only qualified personnel should perform programming, maintenance, and sensor verification*

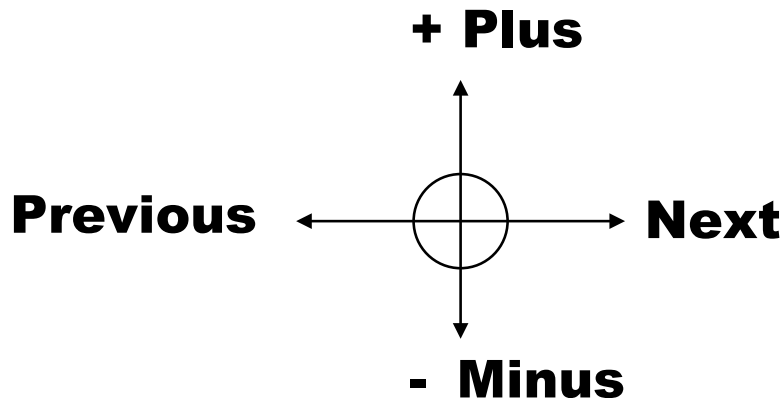

Plus – Pushing the joystick in this direction increases the value

Minus – Pushing the joystick in this direction decreases the value

Next – Pushing the joystick in this direction moves you to the next level of the menu hierarchy.

Previous – Pushing the joystick in this direction takes you out to the last level of menu hierarchy.

Enter – Pushing the joystick directly in the center enters the information into the microprocessor

4.9.2. Program Flowchart

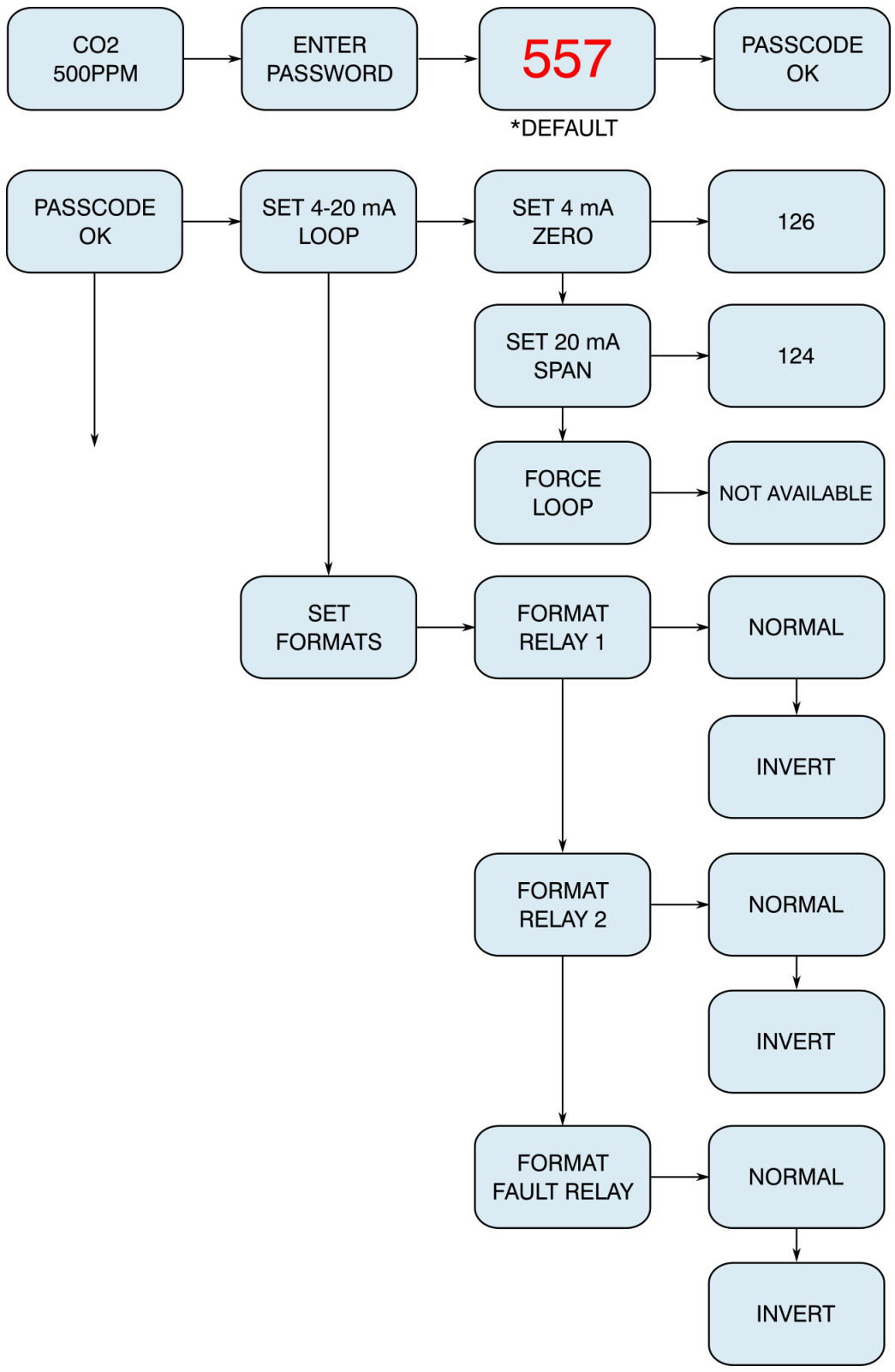

NUMERICAL VALUES
ARE EXAMPLES
AND NOT DEFAULTS!

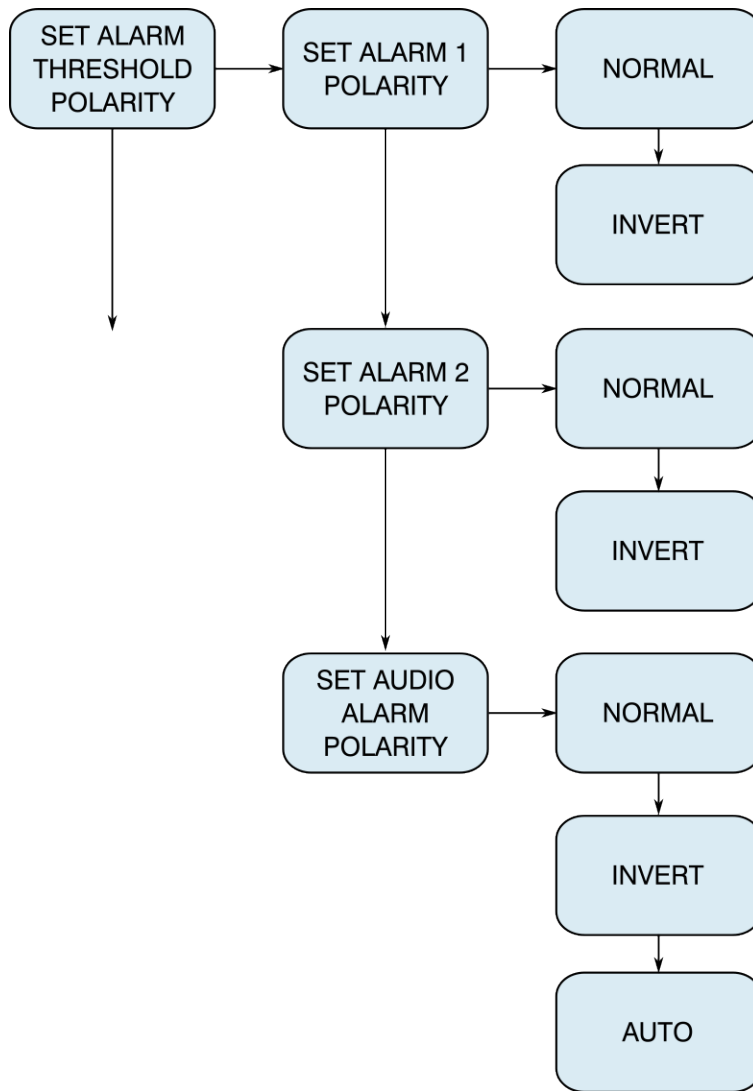

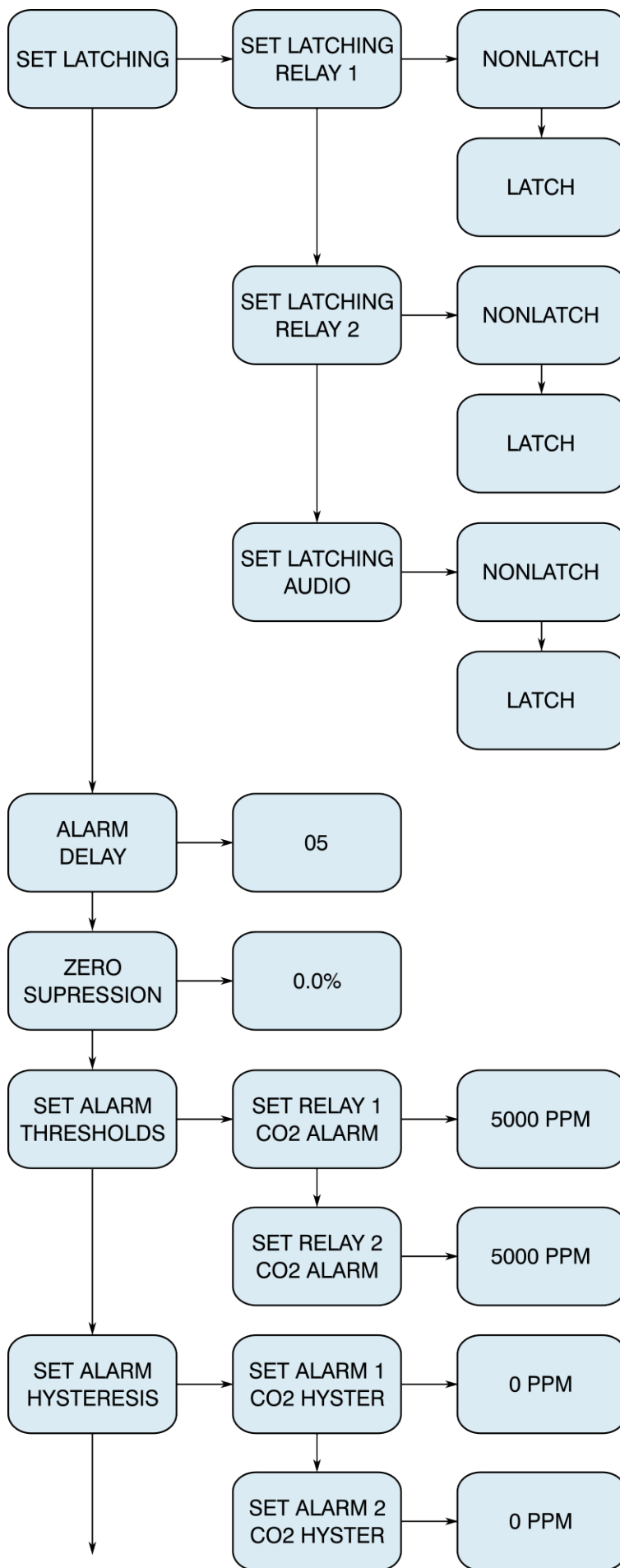

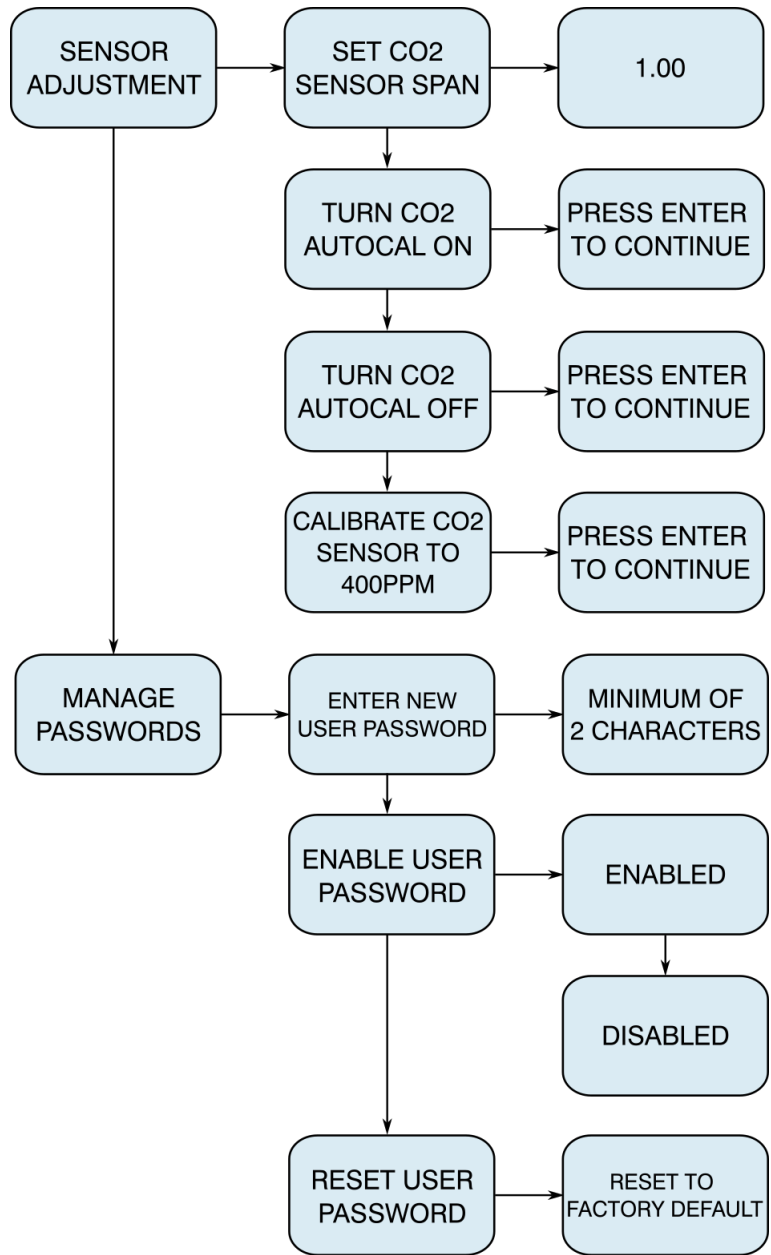

4.9.3. Entering the Password

The CO_2 PureAire monitor is supplied with a factory set password to prevent unauthorized access to the menus. **The Password is 557.** The following explains how to enter the password.

Push the joystick once to the right. **Enter Password** will scroll on the first line of the digital display. The second line will still display the current carbon dioxide level.

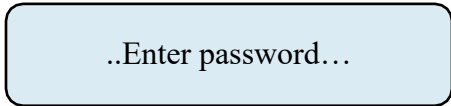

..Enter password...

Push the joystick again to the right to enter the input screen. **The letter A will appear and flash.**

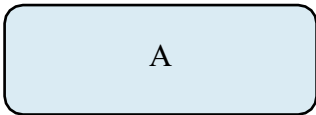

A

NOTE: The display has characters that start with A through Z and 0 through 9. Pushing the joystick up or down will permit you to scroll through the alphanumeric characters.

Push the joystick up or down to enter the first digit. The display is an alphanumeric display and toggles from A through Z followed by 0 to 9. The character to be entered will flash.

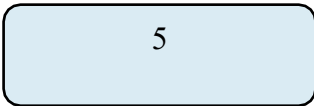

5

Push the joystick again to the right to select the second entry. Push the joystick up or down to select the second digit. The character being entered will flash and the first character entered will remain lit.

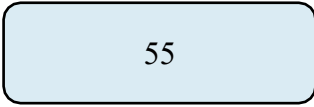

55

Push the joystick again to the right to select the third entry. Push the joystick up or down to select the third and final digit. The character being entered will flash and the first and second characters entered will remain lit. You are now ready to enter the 3-digit password.



557

Push the joystick in the center to enter the password. If you entered it correctly the display will scroll **Password OK.**



...PassCode OK.....

NOTE: If an incorrect password has been entered, the display will indicate Password Failed. Push the joystick to the left to access the monitoring mode. From this mode, you can reenter the password again.

4.9.3.1. Changing the User Password

The CO_2 PureAire monitor is supplied with a factory set password to prevent unauthorized access to the menus. The user can change this password and the following explains how to change the password.

Push the joystick down to access the **Manage Passwords Menu**. **Manage Passwords** will scroll on the first line of the digital display. The second line will still display the current carbon dioxide level.



..Manage Passwords...

Push the joystick to the right to enter the input screen. **Enter New User Password** will scroll on the first line of the digital display



...Enter New User Password...

Push the joystick to the right to enter the input screen. **The letter A will appear and flash.**



A

NOTE: The display has characters that start with A through Z and 0 through 9. Pushing the joystick up or down will permit you to scroll through the alphanumeric characters.

Push the joystick up or down to enter the first digit. The display is an alphanumeric display and toggles from A through Z followed by 0 to 9. The character to be entered will flash.



2

Push the joystick again to the right to select the second entry. Push the joystick up or down to select the second digit. The character being entered will flash and the first character entered will remain lit.



25

Push the joystick again to the right to select the third entry. Push the joystick up or down to select the third and final digit. The character being entered will flash and the first and second characters entered will remain lit. You are now ready to enter the 3-digit password.

253

Push the joystick in the center to enter the password. This will display the next command,
Re-Enter New Password

...Re-Enter New Password...

Push the joystick to the right to enter the input screen. **The letter A will appear and flash.**

A

Push the joystick up or down to enter the first digit. The display is an alphanumeric display and toggles from A through Z followed by 0 to 9. The character to be entered will flash.

2

Push the joystick again to the right to select the second entry. Push the joystick up or down to select the second digit. The character being entered will flash and the first character entered will remain lit.

25

Push the joystick again to the right to select the third entry. Push the joystick up or down to select the third and final digit. The character being entered will flash and the first and second characters entered will remain lit. You are now ready to enter the 3-digit password.

253

Push the joystick in the center to enter the password. If you entered it correctly the display will scroll **“New Password Entry OK”**.

...New Password Entry OK...

NOTE: If on the second entry the password entered was different from the first, the display will take you back to the “Re-enter Password Screen”. You will need to repeat steps 2 through 11. If you do not enter the password correctly, the monitor remembers the last password that was properly input.

4.9.3.2. Enable User Password

This menu permits the user to activate or disable the password function on the Carbon Dioxide monitor. Push the joystick down. “**Enable User Password**” will scroll on the first line of the digital display

...Enable User Password...

Push the joystick right to display the status. If enabled it will display “**Enabled**”

Enabled

Push the joystick up or down to change the status. Once enabled or disabled is selected, Push the joystick in (like a doorbell) to enter the new status. If correctly entered the Display will scroll “**Enable User Password**”

...Enable User Password...

4.9.3.3. Reset User Password

This menu permits you to reset the password back to 557, as set at the factory.

...Reset User Password...

Push the joystick right to display the menu, “**Reset to factory Default**”.

...Password Reset to factory Default...

Push the joystick in, (like a doorbell) to reset the password back to 557. Push the joystick left 4 times to go back to the measuring mode.

NOTE: If you lose your password please contact PureAire with your serial number or DTM number

CO₂
405PPM

4.10. Entering the Menus

The CO_2 monitor is supplied with main menus with sub-menus to adjust mA outputs and alarm relay settings.

4.10.1. Set 4-20mA loop

.Set 4-20mA loop..

This main menu will permit the adjusting of the 4mA and 20mA output from the CO_2 monitor. This menu will provide the function that will send an actual output between 4mA and 20 mA to test any remote control and alarm system attached to the CO_2 monitor.

NOTE: *To read the mA output, the CO_2 monitor must either be connected to a remote PLC controller or SCADA system. You can also connect the CO_2 monitor to a DC ammeter to read the mA output. Please consult PureAire for more information.*

From this main menu, pushing the joystick to the right will select the sub-menu and the digital display will scroll the following:

..Set 4mA zero...

This is the menu at which to adjust the 4mA output being sent from the CO_2 Monitor.

To change this value, push the joystick right to display the 4 mA setting. The display will indicate a value between 0 and 255 counts. Pushing the joystick up increases the value and pushing the joystick down decreases the value. The 4mA output being sent from the CO_2 monitor will change as the number on the digital display changes.

128
470PPM

Push the joystick to the left to enter the value and bring you back to the previous Main menu. The digital display will scroll the following:

...Set 4mA zero.....

...Set 20mA Span...

Push the joystick down to access the next sub-menu; **Set 20mA Span will scroll.**

This is the menu at which to adjust the 20mA output being sent from the CO₂ Monitor.

To change this value, push the joystick right to display the 20mA span setting. The display will indicate a value between 0 and 255 counts. Pushing the joystick up increases the value and pushing the joystick down decreases the value. The 20mA output being sent from the CO₂ monitor will change as the number on the digital display changes.

85
470PPM

Push the joystick to the left to enter the value and bring you back to the previous Main menu. The digital display will scroll the following:

...Set 20mA span.....

4.10.2. Set Formats

This is the menu at which to adjust the relay states for the gas alarm relays and the individual instrument fault relay.

Push the joystick down to access the next main menu, **Set Formats**. The display will scroll the following:

...Set Formats...

This menu will permit the setting of the two alarm relays and the fault relay settings from normally de-energized state, **Normal**, to normally energized state, **Inverted**.

From this main menu, pushing the joystick to the right will select the sub-menu and the digital display will scroll the following:

..Format Relay 1 CO₂...

This is the menu at which to adjust the CO₂ alarm relay state...

To change this value, push the joystick right to display the relay state. The display will indicate **NORMAL**. This is the factory default state for the alarm relay. Pushing the

joystick down will change the relay state from INVERT to NORMAL.

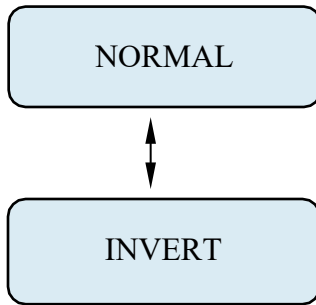

NOTE: When the CO₂ relay state is changed to INVERT, the Orange alarm LED will illuminate.

After entering the relay state push the joystick left to enter the setting. The display will scroll the following:

..Format Relay 1 CO2...

From this main menu, pushing the joystick down will select the next sub-menu to adjust the second alarm relay state. The digital display will scroll the following:

..Format Relay 2

To change this value, push the joystick right to display the relay state. The display will indicate **NORMAL**. This is the factory default state for the alarm relay. Pushing the joystick down will change the relay state from NORMAL to INVERT.

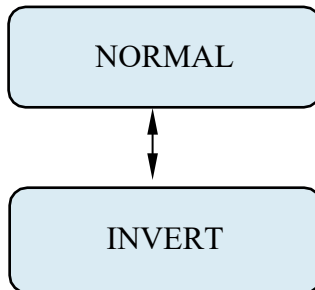

NOTE: When the CO₂ relay state is changed to INVERT, the Red alarm LED will illuminate.

After entering the relay state push the joystick left to enter the setting. The display will scroll the following:

... Format Relay 2 ..

From this main menu, pushing the joystick down will select the next sub-menu to adjust the Fault alarm relay state. The digital display will scroll the following:

..Format Fault Relay...

To change this value, push the joystick right to display the relay state. The display will indicate **NORMAL**. This is the factory default state for the fault relay. Pushing the joystick down will change the relay state from **NORMAL** to **INVERT**.

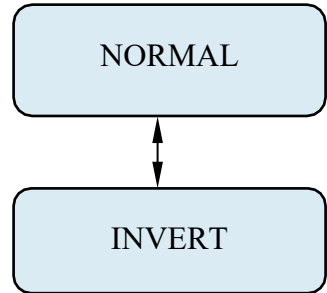

NOTE: When the Fault relay state is changed to **INVERT**, the Yellow alarm LED will illuminate.

After entering the relay state push the joystick left to enter the setting. The display will scroll the following:

..Format Fault Relay...

Push the joystick left again to get back to the next menu. The display will scroll the following:

...Set Formats...

4.10.3. Set Alarm Threshold Polarity

Alarm Threshold Polarity determines if an alarm concentration is set above or below a threshold value. For example, if an alarm of 19.0% for oxygen is selected, the Alarm Threshold Polarity must be set to **Invert** for the monitor's alarm to activate when the reading goes below 19.0%. For CO₂ gases selecting a **Normal** setting for the Alarm Threshold Polarity means that the system will alarm when the gas concentration exceeds, goes above, an alarm set point. This menu will permit the selection of the alarm polarity. To access this menu from the "Set Formats" menu, push the joystick down to display the **Set Alarm Threshold Polarity** adjustment menu. This will scroll on the digital display.

..Set Alarm Threshold Polarity..

Push the joystick right to access the first sub-menu; **Set Alarm 1 CO₂ Polarity** will scroll on the display. This is the menu at which to adjust the CO₂ alarm polarity state on the CO₂ Monitor.

..Set Alarm 1, CO₂, Polarity...

To change this value, push the joystick right to display the relay state. The display will indicate **NORMAL**. Pushing the joystick down will change the relay state from NORMAL to INVERT.

NORMAL



INVERT

NOTE: When the CO₂ relay state is changed to INVERT, the internal horn will sound.

After entering the polarity push the joystick left to enter the setting. The display will scroll the following:

..Set Alarm 1, CO₂, Polarity..

Push the joystick down to access the next sub-menu; **Set Alarm 2, CO₂, Polarity** will scroll on the display. This is the menu at which to adjust the second level alarm polarity state on the CO₂ Monitor.

..Set Alarm 2, CO2, Polarity ..

To change this value, push the joystick right to display the relay state. The display will indicate **INVERT**. Pushing the joystick down will change the relay state from INVERT to NORMAL.

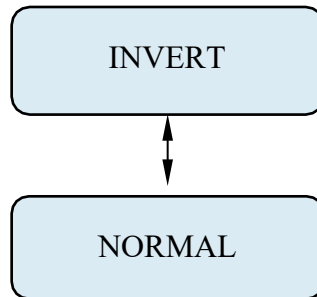

NOTE: When the CO₂ relay state is changed to NORMAL, the internal horn will sound...

After entering the polarity push the joystick left to enter the setting. The display will scroll the following:

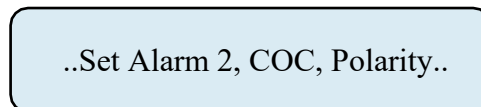

NOTE: The Set Audio Alarm Polarity is not available on the CO₂ monitor

4.10.4. Set Latching

This is the menu at which to adjust the relay alarm state for the CO₂ alarm relays and the individual instrument fault relay. The selection permits setting the relays to a latching or non-latching state. In a latching state, the relay will remain activated until the user manually selects the Enter Key. In a non-latching state, the alarm relay will automatically reset once the gas concentration has returned to below the alarm settings



From this main menu, pushing the joystick to the right will select the sub-menu and the digital display will scroll the following:

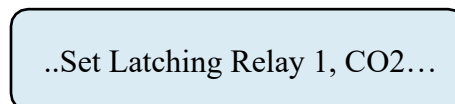

This is the menu at which to adjust the CO₂ alarm relay state on the CO₂ Monitor.

To change this value, push the joystick right to display the relay state. The display will indicate **NONLATCH**. Pushing the joystick down will change the relay state from **NONLATCHING** to **LATCHING**.

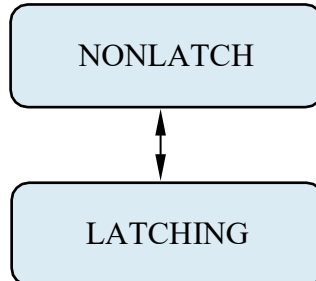

After entering the relay setting push the joystick left to enter the setting. The display will scroll the following:



Push the joystick down to access the next sub-menu; **Set Latching-Relay 2, CO₂**, will scroll on the display. This is the menu at which to adjust the second CO₂ alarm relay state on the CO₂ Monitor.

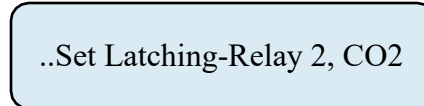

To change this value, push the joystick right to display the relay state. The display will indicate **NONLATCH**. Pushing the joystick down will change the relay state from **NONLATCHING** to **LATCHING**.

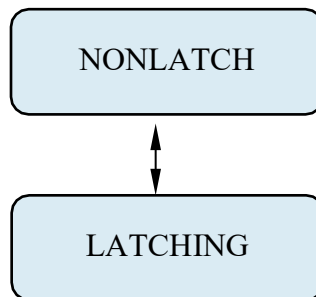

After entering the relay setting push the joystick left to enter the setting. The display will scroll the following:

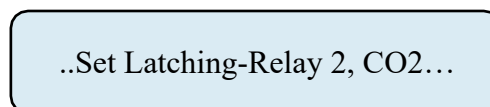

Push the joystick down to access the next sub-menu; **Set Latching-Audio Alarm** will scroll on the display. This is the menu at which to adjust the Audio alarm relay state on the CO₂ Monitor.

..Set Latching-Audio Alarm..

To change this value, push the joystick right to display the relay state. The display will indicate **NONLATCH**. Pushing the joystick down will change the relay state from **NONLATCH** to **LATCHING**.

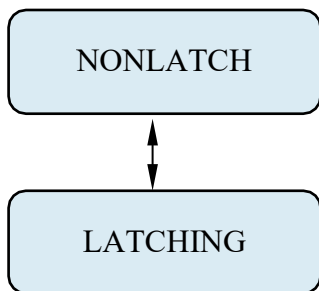

After entering the relay setting push the joystick left to enter the setting. The display will scroll the following:

..Set Latching-Audio Alarm..

4.10.5. Resetting a Latching Alarm

To reset a latching alarm relay, you must enter the password correctly and then push the joystick down to enter the reset command. The CO₂ monitor also has an internal 2-pin terminal block for connecting a remote reset switch. (See Alarm Relay board, section 1.2.7)

4.10.6. Set Alarm Delay

Push the joystick down to access the next main menu, **Alarm Delay**. The display will scroll the following:

...Alarm Delay...

This is the amount of time an alarm level concentration of either oxygen or carbon dioxide must be present before the instrument's gas concentration alarms will be activated. This menu will permit setting a user-selected time delay for activating the CO₂ alarm.

You can select from 0 seconds up to 255 seconds after an alarm level has been exceeded before the alarm relays to activate.

To change this value, push the joystick right to display the time screen. The display will indicate a value between 0 and 255 seconds. Pushing the joystick up increases the value and pushing the joystick down decreases the value

05

After entering the relay setting push the joystick left to enter the setting. The display will scroll the following:

...Alarm Delay...

NOTE: The alarm delay is only available for the CO₂ alarms 1 and 2. There is no delay for the fault relay. Any system fault will immediately activate the Fault Relay.

4.10.7. Set Zero Suppression

This function is not used on the CO₂ monitor. It is only used to decrease the sensitivity of selected toxic and corrosive gas sensors. It is disabled on the Dual monitor.

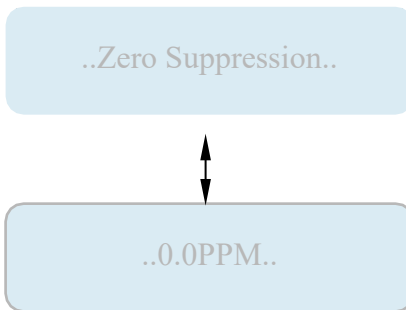

4.10.8. Set Alarm Thresholds

..Set Alarm Thresholds..

This main menu will permit adjusting the Carbon Dioxide ppm level that will activate their respective alarm relays. It will also activate the internal audio horn.

From this main menu, pushing the joystick to the right will select the first sub-menu and the digital display will scroll the following: **Set Relay 1, CO₂, Alarm Threshold.**

..Set Relay 1, CO₂, Alarm Threshold...

This is the gas concentration at which the CO₂ level must be displayed to activate the alarm. To change the displayed value, push the joystick to the right to display the CO₂ level alarm setting. The display will indicate a value between 0 ppm and 50,000 ppm.

Pushing the joystick up increases the value and pushing the joystick down decreases the value.

5000PPM

After entering the alarm setting push the joystick left to enter the setting. The display will scroll the following:

..Set Relay 1, CO2, Alarm Threshold...

Push the joystick down to access the next sub-menu; **Set Relay 2 Alarm Threshold**, will scroll on the digital display.

..Set Relay 2, CO2, Alarm Threshold...

This is the gas concentration at which the second CO₂ level must be displayed to activate the alarm. To change the displayed value, push the joystick to the right to display the CO₂ level alarm setting. The display will indicate a value between 0 and 50,000ppm.

Pushing the joystick up increases the value and pushing the joystick down decreases the value.

10,000PPM

After entering the alarm setting push the joystick left to enter the setting. The display will scroll the following:

..Set Relay 2, CO2, Alarm Threshold...

Push the joystick left once to return to the **Set Alarm Thresholds menu**. The display will scroll the following:

..Set Alarm Thresholds..

4.10.9. Set Alarm Hysteresis

PureAire's CO₂ monitor may be used as a control system. When used to regulate carbon dioxide levels the need of a dead band, "hysteresis" may be required for the alarm relays. This menu will permit the setting of the alarm hysteresis to the desired concentration of Carbon Dioxide. When using hysteresis, the alarm set point now becomes an average alarm setting for an action to occur. When adding the hysteresis value to the alarm set point, this then defines the alarm and dead band for an action to occur.

For example, if you require a valve to close at 5,000ppm level and to reopen again at 5,050 ppm, you will set the Alarm Threshold at 5000ppm and set the hysteresis value at 50ppm.

Average Alarm set point = 5,000 set the Hysteresis to 50ppm= Valve Off (5,050ppm)

To access this menu, push the joystick down to display the **Set Alarm Hysteresis** menu. This will scroll on the digital display.

..Set Alarm Hysteresis...

Push the joystick right to access the **Set Alarm 1, CO₂, Hysteresis**.

..Set Alarm 1, CO₂, Hysteresis...

It will display a value 00 PPM, (factory default). Pushing the joystick up increases the CO₂ PPM up to a maximum value of 1000 PPM. Adjust the digital display until the desired hysteresis value is selected.

50 PPM

After entering the alarm setting push the joystick left to enter the setting. The display will scroll the following:

..Set Alarm 1, CO₂, Hysteresis...

Push the joystick down to access the next sub-menu; **Set Alarm 2, CO₂, Hysteresis.** on the digital display.

..Set Alarm 2, CO₂, Hysteresis...

It will display a value 00 PPM, (factory default). Pushing the joystick up increases the CO₂ PPM up to a maximum value of 1000 PPM. Adjust the digital display until the desired hysteresis value is selected.

50 PPM

After entering the alarm setting push the joystick left to enter the setting. The display will scroll the following:

..Set Alarm 2, CO₂, Hysteresis...

Pushing the joystick again to the right will display a value 0.0%. Pushing the joystick up increases the percentage up to a maximum value of 2.5%. Adjust the digital display until the desired hysteresis value is selected.

..Set Alarm Hysteresis...

4.10.10. Auto Calibrate feature for CO₂ NDIR sensor

The CO₂ sensor is set to automatically calibrate itself to the ambient carbon dioxide level on earth. The ambient CO₂ level is 400 PPM. The CO₂ monitor has a menu that permits you to activate this feature by “turning on” this feature. If the CO₂ monitor is not exposed to constant high levels of CO₂, the sensor will automatically adjust the baseline setting and there is no further action required by the user. The sensor is factory calibrated and requires no user calibration.

NOTE: DO NOT use the auto-calibration feature if you are monitoring continuous levels of CO₂ for control of grow rooms. The monitor needs to be at ambient lower levels for the autocal feature to operate properly.

To access the Auto Calibration mode, go to the Sensor Adjustment main menu.

..Sensor Adjustment..

Press the joystick right to access the **Set CO₂ sensor span** sub-menu.

..Set CO₂ sensor span..

Push the joystick down to access the **Turn CO₂ autocal on** the menu. The display will scroll the following:

..Turn CO₂ autocal on..

To turn ON this feature push the joystick right. The display will scroll the following:

..Press ENTER to continue..

Push the joystick in, (like a doorbell) to activate the autocal feature. The audio horn and CO₂ alarm horn will activate momentarily. Every week the CO₂ sensor will automatically adjust back to 400PPM which is the ambient level on earth.

NOTE: DO NOT use the auto-calibration feature if you are monitoring continuous levels of CO₂ for control of grow rooms. The monitor needs to be at ambient levels for the autocal feature to operate properly.

You can also disable or “turn off” the auto-calibration feature. If the CO₂ monitor is exposed to constant high levels of CO₂, the user **MUST** inhibit, “turn off” the autocal feature and perform a manual baseline adjustment approximately every six months or more often if desired. To turn OFF the auto-calibration feature, push the joystick down to access the menu.

The display will scroll the following:

..Turn CO₂ autocal off..

To turn OFF this feature push the joystick right. The display will scroll the following:

..Press ENTER to continue..

Push the joystick in, (like a doorbell) to activate the autocal feature. Push the joystick in, (like a doorbell) to activate the autocal feature. The CO₂ alarm horn will activate momentarily. The auto-calibration feature has now been disabled. You can now **manually** calibrate the CO₂ sensor to ambient 400 PPM one demand. *Refer to section 4.10.1., Sensor calibration CO₂.*

4.10.11. Main Operation Mode

To select the main menu from any sub-menu, push the joystick left until the Main Menu appears. The digital display will indicate the following:

CO2
400PPM

4.11. Maintenance & Sensor Verification

Only qualified personnel should perform maintenance and sensor verification

4.11.1. Sensor Calibration, CO₂

PureAire incorporates an NDIR (Non-Dispersive Infrared) CO₂ sensor into the CO₂ Monitor. The sensor is factory calibrated and will always provide an accurate reading that is the difference between a baseline setting and the actual CO₂ measurement. As typical with most NDIR sensors, long-term drift can affect the baseline setting. To compensate for this drift, an automatic background calibration function is built into the sensor and is enabled by default from the factory. This calibration feature assumes that during a 24-hour period, the monitored CO₂ levels return to normal ambient conditions, such as in an office environment or spaces that are unoccupied during the evening.

If the monitor is constantly exposed to elevated levels of CO₂, for example, in an agricultural growing room, the auto-calibration feature should be inhibited, “turned off” and a manual calibration performed approximately every six months. See Section 4.9.10. to turn off the autocal feature.

NOTE: If auto-calibration is turned off or if manual verification is desired, PureAire recommends verifying the CO₂ sensor response using 1% (10,000 PPM) and 2.5% (25,000 PPM) CO₂ calibration gas.



CAUTION

DO NOT ADJUST the CO₂ sensor unless you are certain that the CO₂ level has returned to normal ambient conditions, such as in an outdoor environment or spaces that are unoccupied. If using calibrated CO₂ span gas, ensure that the gas is not being diluted with room air.

To perform a manual adjustment of the CO₂ sensor to ambient 400PPM, use the following procedure. Use the joystick to enter the password, then push the joystick to the right and navigate to the “Sensor Adjustment” menu. The display will scroll

...Sensor adjustment..

Push the joystick right once and the display will scroll:

...Set CO₂ sensor span..

Push the joystick right once to display:

1.00
600PPM

To adjust the baseline setting, expose the monitor to ambient air, either outside or in a well-ventilated room for about 5 minutes. **OR** expose the sensor to a span gas cylinder with a certified concentration of CO₂. Push the joystick up to increase the CO₂ reading or push the joystick down to decrease the CO₂ reading displayed on the second line of the digital display.

When done setting the calibration, push the joystick left once and the display will scroll:

...Set CO2 sensor span..

4.11.2. Adjusting the CO₂ sensor manually to an exact 400PPM value

There is a provision in the software for a user to manually adjust the reading of the CO₂ monitor to an exact 400ppm value. **DO NOT ADJUST the CO₂ sensor unless you are certain that the CO₂ level has returned to normal ambient conditions, such as in an outdoor environment or spaces that are unoccupied. Be careful not to breathe near the sensor because a person can exhale very high concentrations, (30,000PPM) of CO₂.**

To perform a manual adjustment of the CO₂ sensor to an exact 400PPM, use the following procedure. Use the joystick to enter the password, then push the joystick to the right and navigate to the “Sensor Adjustment” menu. The display will scroll:

...Sensor adjustment..

Push the joystick right once and the display will scroll:

...Set CO2 sensor span..

Push the joystick down once to display:

..Calibrate CO2 sensor to 400 PPM...

Push the joystick right once to display:

..Press ENTER to continue..

Push the joystick in, (like a doorbell) to set the reading to 400PPM. You have now reset the CO₂ sensor to 400PPM. To exit the calibration menu, push the joystick left four times to display the monitoring mode.

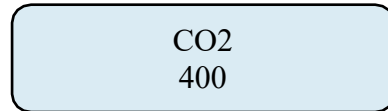

CO2
400

5: Appendix

CONTACTOR/FAN CONNECTION

EXTERNAL RELAY FOR LOADS >2A

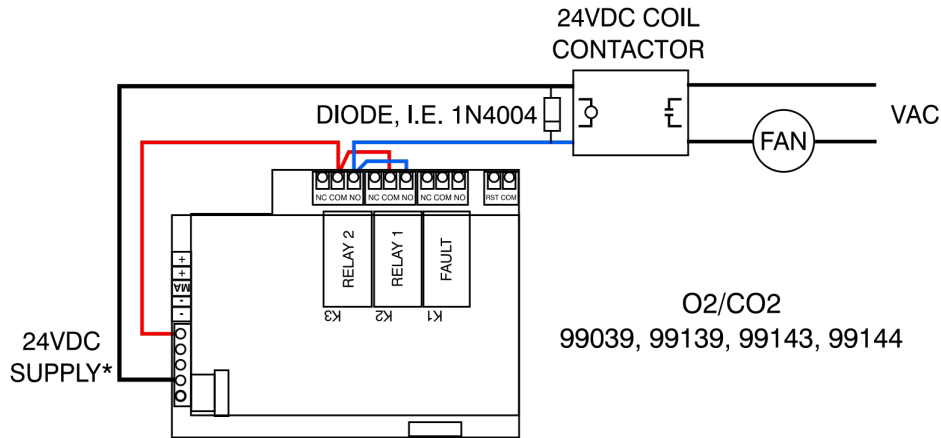
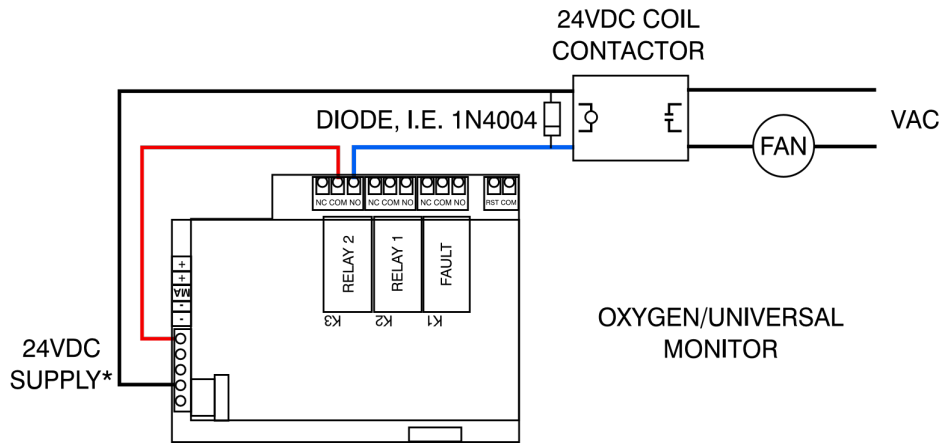

DIAGRAMS FOR 99016, 99029, 99129, 99028, 99145, 99097, 99141, 99035, 99128, 99020, 99045, UNLESS NOTED.

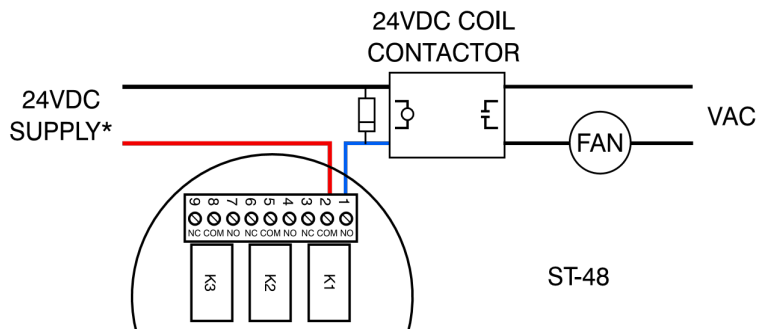

NOTE: ENSURE CONTACTOR CHOSEN HAS CORRECT COIL VOLTAGE AND IS CURRENT-RATED FOR YOUR LOAD

* OK TO USE EXTERNAL SUPPLY AS LONG AS VOLTAGE IS 24VDC/AC OR LESS

How to convert 4-20mA current output to a 1-5 VDC voltage output

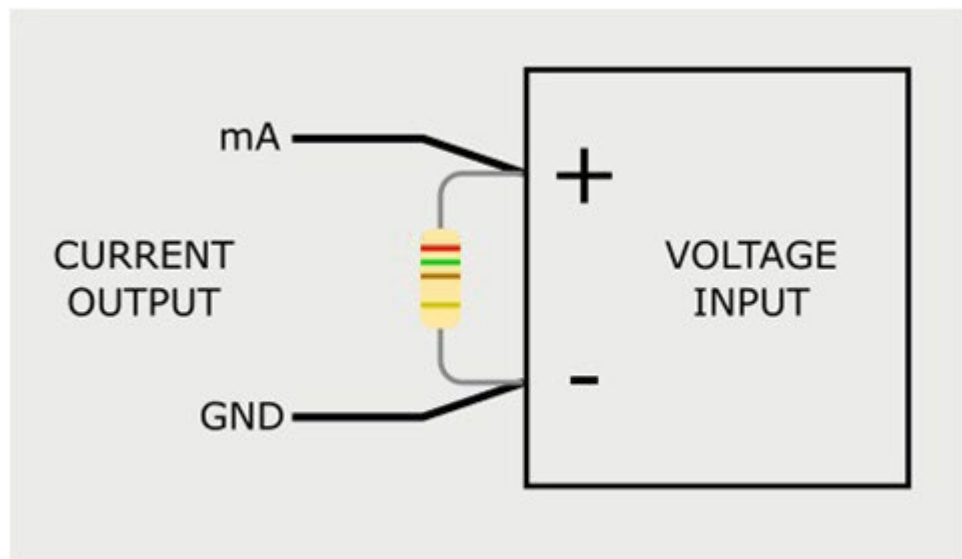
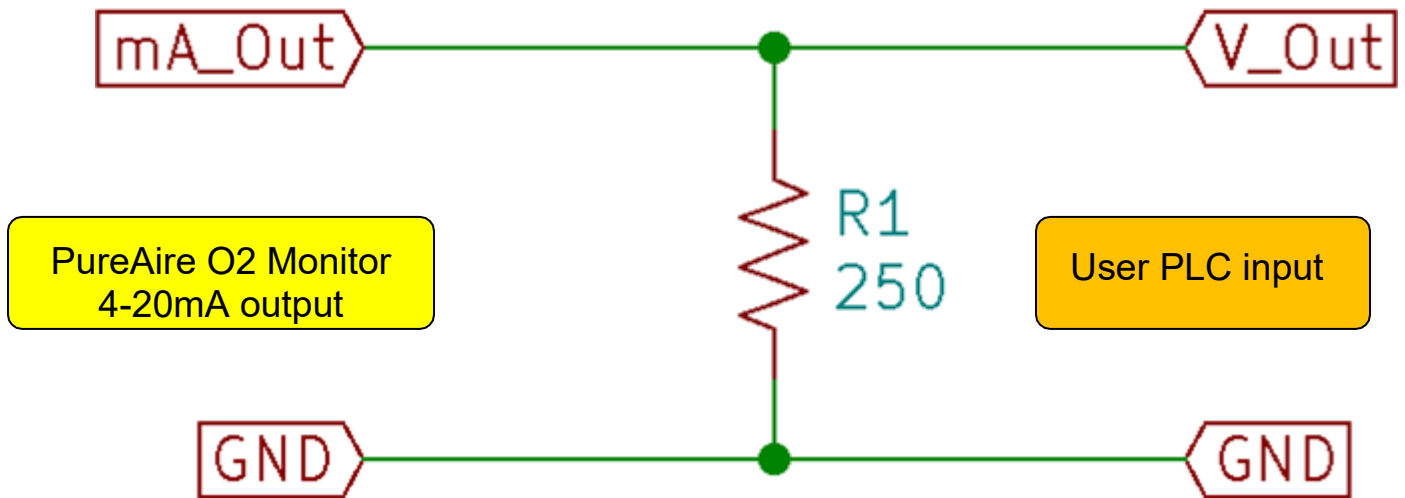

Attach 250-ohm resistor to the PLC or device input